

Exact-Fit Pro-Touring-Style Roll Bars and Cages for Popular GM and Ford Muscle Cars



Roll Cage



Roll Bar

The gStreet™ Exact-Fit roll cages and roll bars are intended for pro-touring performance applications to add a level of protection and increase chassis rigidity. To improve interior clearance, fit, and accessibility, cage sides and rear struts feature additional bends not normally found in race-duty roll cages. Both roll bars and cages are constructed of mandrel-bent 1-3/4 x .134" wall mild-steel tubing. Optionally available is an upgrade to 1-3/4 x .125" DOM tubing for compliance with SCCA rules. Door bar installation options include high-mount race style bars and low hip-mount street bars (shown) with weld-in and optional removable versions of each. A removable back brace is also included as standard. Optional removable firewall-forward support struts can also be added to further improve chassis stiffness. These attach directly to the upper firewall at the fender mount, the most rigid part of the firewall, and attach to the suspension subframe using our weld-on Gemini connectors.

Features/Benefits:

- Significantly increases chassis rigidity
- Maximizes interior space using multiple CNC compound bend angles
- Expert cage fabrication quality and fit with off-the-shelf convenience and availability
- Removable back brace included
- Optionally, door bars can be converted to removable
- Removable Hardware Styles: standard Faspins, quick-release L-handle pins, or polished-stainless spud bolts

gStreet Exact-Fit Roll Cage

High-clearance cage sides, windshield brace, and rear struts makes our Exact-Fit roll cage an excellent choice for pro-touring performance applications to add a level of protection and increase chassis rigidity. Cages are mandrel bent in a variety of steel tubing types, including 1-5/8 x .134" mild-steel, 1-5/8 x .083" 4130, 1-3/4 x .134" mild-steel, and SCCA-compliant 1-3/4 x .125" DOM. The removable back brace with billet clevis ends comes standard. Door bars are included and can be installed at a 'street style', hip-height position for easier entry and exit from the vehicle, or positioned

at a higher 'race style' position for increased driver protection. Optionally available hardware permits removal of door bars when greater access is required. Spring-loaded faspins are standard removable bar hardware, with push-button L-handle locking pins and polished-stainless spud bolts offered as an upgrade option.

- '67-81 Camaro / Firebird
- '64-70 Mustang



- **Cages Available In...**
- **1-5/8" x .134" Mild Steel**
- **1-5/8" x .083" 4130**
- **1-3/4" x .134" Mild Steel**
- **1-3/4" x .125" DOM**

Features/Benefits:

- Significantly increases chassis rigidity
- Maximizes interior space using multiple CNC compound bend angles
- Expert cage fabrication quality and fit with off-the-shelf convenience and availability
- Removable back brace included
- Optionally, door bars can be converted to removable
- Removable Hardware Styles: standard Faspins, quick-release L-handle pins, or polished-stainless spud bolts

Swing-Out Clevis Sets

Dual-purpose design makes a roll-cage side bar or back brace fully removable — or, simply swing it out for easy entry! In gStreet applications, clevis sets are provided for the driver's and passenger's cage-side bars, and for the main-hoop back brace. Clevis tube adapters match the specific ID and OD the selected cage or roll bar. Swing-out side bars are NHRA-accepted.

Safety Notes – gStreet Roll Cage/Bar For safety purposes, roll-cage padding must be applied along any areas of the cage that occupants may come into contact with. Due to the additional cage-side and rear-strut bends, and removable door bars and back brace the g-Machine cages are not intended for competitive motorsports. Our competition series roll-cages are designed for ultimate strength and safety, and are better suited for serious competitive applications.

gStreet Exact-Fit Roll Cage

Side Bar Mounting Options

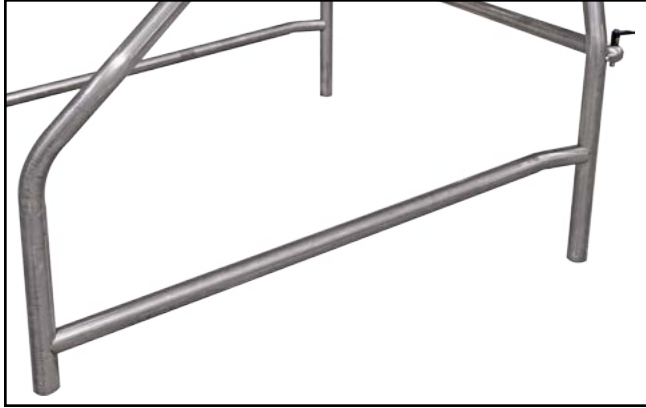

Street Style - Lower hip-height bars provide greater vehicle access and can be made removable with optional faspins, quick-release L-handle pins, or spud bolts.

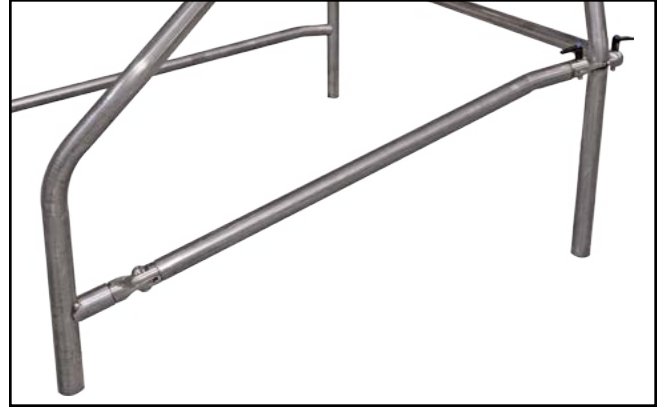

Race Style - Higher mounted bars provide greater protection and can be made removable with optional faspins, quick-release L-handle pins, or spud bolts.

Removable Hardware Options



Standard Faspins with spring-loaded ball lock.



Polished Spud Bolt shown at lower side bar clevis.



Quick-Release L-Handle Pins side bar and back brace clevis.

1-5/8" Mild Steel - Exact-Fit Roll Cage

7052-F10	'67-69 CAMARO, FIREBIRD, 1-5/8 X .134", ERW
7052-F20	'70-81 CAMARO, FIREBIRD, 1-5/8 X .134", ERW
7052-M10-C	'64-70 MUSTANG COUPE, 1-5/8 X .134", ERW
7052-M10-F	'64-70 MUSTANG FASTBACK, 1-5/8 X .134", ERW

1-5/8" 4130 - Exact-Fit Roll Cage

7053-F10	'67-69 CAMARO, FIREBIRD, 1-5/8 X .083", 4130
7053-F20	'70-81 CAMARO, FIREBIRD, 1-5/8 X .083", 4130
7053-M10-C	'64-70 MUSTANG COUPE, 1-5/8 X .083", 4130
7053-M10-F	'64-70 MUSTANG FASTBACK, 1-5/8 X .083", 4130

1-3/4" Mild Steel - Exact-Fit Roll Cage

7054-F10	'67-69 CAMARO, FIREBIRD, 1-3/4 X .134", ERW
7054-F20	'70-81 CAMARO, FIREBIRD, 1-3/4 X .134", ERW
7054-M10-C	'64-70 MUSTANG COUPE, 1-3/4 X .134", ERW
7054-M10-F	'64-70 MUSTANG FASTBACK, 1-3/4 X .134", ERW

1-3/4" DOM - Exact-Fit Roll Cage

7055-F10	'67-69 CAMARO, FIREBIRD, 1-3/4 X .125", DOM
7055-F20	'70-81 CAMARO, FIREBIRD, 1-3/4 X .125", DOM
7055-M10-C	'64-70 MUSTANG COUPE, 1-3/4 X .125", DOM
7055-M10-F	'64-70 MUSTANG FASTBACK, 1-3/4 X .125", DOM

Options - Exact-Fit Roll Cages

CAGE SIDE OPTIONS	IN FRONT OF DASHBOARD
	THROUGH DASHBOARD
SIDE BAR OPTIONS	WELD-IN SIDE BARS
	REMOVABLE SIDE BARS SWINGOUT
	REMOVABLE SIDE BARS, QUICK LOCK L-HANDLE
REAR STRUT OPTIONS	ATTACHES TO G STREET FRAME
	ATTACHES TO OEM TRUNK FLOOR
	ATTACHES TO DSE 4-LINK COIL-OVER CROSSMEMBER
BACK BRACE OPTIONS	STANDARD BOLT-IN ATTACHMENT
	PUSH BUTTON QUICK LOCK L-HANDLE
	STAINLESS SPUDS



gStreet Exact-Fit Roll Bar

Featuring 1-3/4 x .134", mild-steel construction and high-clearance rear struts, our Exact-Fit roll bar is an excellent street-car-friendly choice. A removable back brace is included for easier access to the rear seat area. The low hip-height, weld-in side bars allow easy access as well as increase rigidity of the Camaro unibody structure. Optionally available hardware permits easy removal of the side bars.

Removable hardware options include: spring-loaded faspins, quick-release ball-lock L-handle pins, or polished stainless-steel spud bolts.

- '67-81 Camaro / Firebird
- '64-70 Mustang

Roll Bar (no side bars)

- **Back Brace Hardware Options**
 - Standard Hex Bolts
 - Quick Lock L-Handles
 - Stainless Spuds
- **Rear Strut Options**
 - For gStreet Frame
 - For OEM Trunk Floor
 - For DSE 4-Link Shock Crossmember



Roll Bar with side bars

- **Back Brace Options (see above)**
- **Rear Strut Options (see above)**
- **Side Bar Options**
 - Weld-In Bars
 - Standard Hex Bolts, Removable
 - Quick Lock L-Handles, Removable
 - Stainless Spuds, Removable



gStreet Exact-Fit Roll Bar

Removable Hardware Upgrades



Quick-Release L-Handle Pin - Push-button ball-lock pin available for quick removal of door bar and back brace.



Polished Spud Bolt - Stainless-steel male and female custom fasteners with no snag beveled head.

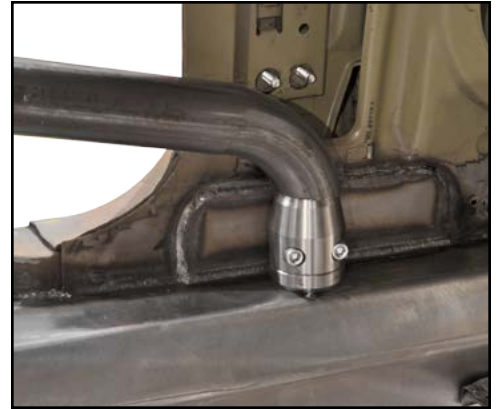

Gemini Connector - OPTION

The optional removable side bar system uses our in-house-engineered Gemini connector to securely fasten the door bar strut to the subframe with no decrease in available room for the driver's feet. The Gemini connector is an easy-to-assemble, precision slip-fit joint that is substantially stronger than a welded joint.



Exact-Fit Roll Bar - No Side Bars

7050-F10	'67-69 CAMARO, FIREBIRD, 1-3/4 X .134", MILD STEEL
7050-F20	'70-81 CAMARO, FIREBIRD, 1-3/4 X .134", MILD STEEL
7050-M10-C	'64-70 MUSTANG COUPE, 1-3/4 X .134", MILD STEEL
7050-M10-F	'64-70 MUSTANG FASTBACK, 1-3/4 X .134", MILD STEEL
REMOVABLE BACK-BRACE OPTIONS	STANDARD HEX BOLT HARDWARE PUSH BUTTON L-HANDLE HARDWARE POLISHED STAINLESS SPUD HARDWARE
REAR STRUT ATTACHMENT OPTIONS	FOR GSTREET FRAME FOR OEM TRUNK FLOOR FOR DSE 4-LINK SHOCK CROSSMEMBER



Exact-Fit Roll Bar with Side Bars

7051-F10	'67-69 CAMARO, FIREBIRD, 1-3/4 X .134", MILD STEEL
7051-F20	'70-81 CAMARO, FIREBIRD, 1-3/4 X .134", MILD STEEL
7051-M10-C	'64-70 MUSTANG COUPE, 1-3/4 X .134", MILD STEEL
7051-M10-F	'64-70 MUSTANG FASTBACK, 1-3/4 X .134", MILD STEEL
SIDE BAR OPTIONS	WELD-IN SIDE BARS, NON-REMOVABLE BOLT-IN, REMOVABLE BARS PUSH BUTTON L-HANDLE, REMOVABLE BARS POLISHED STAINLESS SPUD, REMOVABLE BARS
REMOVABLE BACK-BRACE OPTIONS	STANDARD HEX BOLT HARDWARE PUSH BUTTON L-HANDLE HARDWARE POLISHED STAINLESS SPUD HARDWARE
REAR STRUT ATTACHMENT OPTIONS	FOR GSTREET FRAME FOR OEM TRUNK FLOOR FOR DSE 4-LINK SHOCK CROSSMEMBER



Removable Front Support Struts

Adding tubular struts between the factory upper firewall area and subframe triangulates the front clip, virtually eliminating chassis deflection forward of the firewall. Upper-strut-mount plates attach directly to the '67-81 Camaro firewall at the fender mount, the most rigid part of the firewall. The lower end of the support strut utilizes Chassisworks' exclusive bolt together Gemini connector system.

Installation of the strut and mounts requires minor trimming and welding for individual fit, but can later be unbolted to facilitate regular maintenance or subframe removal.

Fits OEM Subframe or Chassisworks gStreet Subframe



Frame Gemini Connector welds easily to front frame rail.



Firewall Mount Plate shown with standard bolt.



Polished Spud Bolt shown at forward strut firewall mount.

Exact-Fit Front Struts

7060-F1-A	'67-69 CAMARO, FIREBIRD, 1-5/8" X .083 WALL, 4130 STEEL
7060-F1-M	'67-69 CAMARO, FIREBIRD, 1-5/8" X .134 WALL, ERW MILD STEEL
7060-F2-A	'70-81 CAMARO, FIREBIRD, 1-5/8" X .083 WALL, 4130 STEEL
7060-F2-M	'70-81 CAMARO, FIREBIRD, 1-5/8" X .134 WALL, ERW MILD STEEL



7060-F1-A or 7060-F1-M Installed



Exact-Fit Roll Bars

Part Number	Description
7050-XXX	Exact-Fit Roll Bar No Door Bars, 1-3/4" x .134 wall, ERW Mild Steel
7051-XXX	Exact-Fit Roll Bar With Door Bars, 1-3/4" x .134 wall, ERW Mild Steel
BACK BRACE OPTIONS	Standard Bolt-In Attachment for Back Brace
	Push Button Quick Lock L-Handle for Back Brace
	Stainless Spuds for Bolt-In Back Brace Attachment
REAR STRUT OPTIONS	Attaches to g-Street Frame
	Attaches to OEM Trunk Floor
	Attaches to DSE 4-Link Coil-Over Crossmember
SIDE BAR OPTIONS	Weld-In Side Bars
	Removable Side Bars, Bolt-In
	Removable Side Bars, Quick Lock L-Handle
	Removable Side Bars, Bolt-In with Stainless Spuds

Exact-Fit Roll Cages

Part Number	Description
7052-XXX	Exact-Fit Roll Cage, 1-5/8" x .134 wall, ERW Mild Steel
7053-XXX	Exact-Fit Roll Cage, 1-5/8" x .083 wall, 4130 Steel
7054-XXX	Exact-Fit Roll Cage, 1-3/4" x .134 wall, ERW Mild Steel
7055-XXX	Exact-Fit Roll Cage, 1-3/4" x .125 wall, DOM Mild Steel
CAGE SIDE OPTIONS	In Front of Dashboard
	Through Dashboard
SIDE BAR OPTIONS	Weld-In Side Bars
	Removable Side Bars Swingout
	Removable Side Bars, Quick Lock L-Handle
	Removable Side Bars, Bolt-In with Stainless Spuds
REAR STRUT OPTIONS	Attaches to g-Street Frame
	Attaches to OEM Trunk Floor
	Attaches to DSE 4-Link Coil-Over Crossmember
BACK BRACE OPTIONS	Standard Bolt-In Attachment for Back Brace
	Push Button Quick Lock L-Handle for Back Brace
	Stainless Spuds for Bolt-In Back Brace Attachment

Notes:

All prices subject to change. Current pricing available at www.cachassisworks.com.



Chris Alston's Chassisworks, Inc.
8661 Younger Creek Drive
Sacramento, CA 95828

Order: 800-722-2269
Tech: 916-388-0288
Fax: 916-388-0295

sales@cachassisworks.com
www.cachassisworks.com