



[CLICK for More Info Online](#)

Billet-Aluminum Shock and Anti-Roll Bar Packages for 1964-73 Mustangs and Related Models



- Comet 1963-65
- Cougar 1967-73
- Falcon 1963-70
- Mustang 1964-73

Shocks available in factory-valved, single- and double-adjustable versions.

TCP Shock and Anti-Roll Bar Packages

Total Control Products offers a selection of direct-replacement front and rear suspension upgrade packages for classic Mustangs and related models. Kits include front and rear anti-roll bars matched with VariShock Bolt-Ins, a line of high-quality OEM-replacement shock absorbers. Front bars include billet-aluminum chassis mounts and urethane bushings. Rear bars are axle-mounted and feature three endlink adjustment holes to vary the bars spring rate. VariShock billet-aluminum shocks are included in the package and are available as factory-valved or 16-position single- or 256-setting double-adjustable versions to fine tune ride quality and handling performance. Installation takes just a few hours may require drilling and minor trimming to mount the components.

VariShock Bolt-Ins

- Direct-fit OEM replacement shock
- Factory-valved, single- or double-adjustable

Anti-Roll Bars

- Heat-treated alloy steel
- Front and rear anti-roll bars
- Billet-aluminum chassis mounts
- Polyurethane pivot and endlink bushings
- Silver-vein-hammertone powder-coat finish.

Applications

MODEL	YEAR	COMPLETE PACKAGES*	ANTI-ROLL BARS		SHOCKS	
			FRONT ¹	REAR ²	FRONT ³	REAR ³
COMET	1963-1965	TCP ARS-F1	TCP ARFM1-XX	TCP ARRM1-12	VAS 14X47-515	VAS 14X44-715
COMET	1966-1970	TCP ARS-M2	TCP ARFM2-XX	TCP ARRM1-12	VAS 14X67-425	VAS 14X44-715
COUGAR	1967-1970	TCP ARS-M2	TCP ARFM2-XX	TCP ARRM1-12	VAS 14X67-425	VAS 14X44-715
COUGAR	1971-1973	TCP ARS-M3	TCP ARFM3-XX	TCP ARRM3-12	VAS 14X47-425	VAS 14X44-715
FALCON	1963-1965	TCP ARS-F1	TCP ARFM1-XX	TCP ARRM1-12	VAS 14X47-515	VAS 14X44-715
FALCON	1966-1970	TCP ARS-M2	TCP ARFM2-XX	TCP ARRM1-12	VAS 14X67-425	VAS 14X44-715
MUSTANG	1964-1966	TCP ARS-M1	TCP ARFM1-XX	TCP ARRM1-12	VAS 14X67-425	VAS 14X44-715
MUSTANG	1967-1970	TCP ARS-M2	TCP ARFM2-XX	TCP ARRM1-12	VAS 14X67-425	VAS 14X44-715
MUSTANG	1971-1973	TCP ARS-M3	TCP ARFM3-XX	TCP ARRM3-12	VAS 14X47-425	VAS 14X44-715

NOTES

- * - COMPLETE PACKAGES INCLUDE FRONT AND REAR ANTI-ROLL BARS AND SET OF FOUR SHOCKS; AVAILABLE OPTIONS LISTED BELOW.
- 1 - FRONT ANTI-ROLL BAR SIZES: 1" (STREET), 1-1/8" (STREET/AUTOCROSS OR BIG-BLOCK), 1-1/4" (ROAD COURSE/AUTOCROSS)
- 2 - REAR ANTI-ROLL BAR SIZE: 3/4" DIAMETER WITH TWO ENDLINK POSITIONS ON EACH ARM FOR THREE SEPARATE BAR RATES
- 3 - SHOCK VALVING OPTIONS: FACTORY-VALVED, SINGLE-ADJUSTABLE (16-SETTINGS), OR DOUBLE-ADJUSTABLE (256-SETTING COMBINATIONS)

TCP ARS-M1

- Mustang 1964-66

TCP ARS-M2

- Comet 1966-70
- Cougar 1967-70
- Falcon 1966-70
- Mustang 1967-70



TCP ARS-M3

- Cougar 1971-73
- Mustang 1971-73

TCP ARS-F1

- Comet 1963-65



VariShock Bolt-Ins

VariShock Bolt-Ins offer an affordable and versatile, high-end performance improvement over OEM replacements and traditional twin-tube shock absorbers. Our updated design overcomes the major shortcomings of traditional gas shocks and low-end twin-tube shocks. VariShock Bolt-Ins bring a more usable adjustment range and response curve, improved heat dissipation, and lightweight billet-aluminum construction to production vehicles using factory mounting locations. On the street or strip, VariShock offers the ultimate direct-replacement shock absorbers!



Features and Benefits

- All aluminum design for minimum weight
- Made in America
- Urethane bushing mounting eyes and stems
- Individually dyno-tested and calibrated to assure uniform performance
- Revolutionary adjuster mechanism provides shorter body at any travel length
- Rebuildable

Adjustment

- **SensiSet (SS)** - Factory-valved for passenger car street-performance
- **QuickSet 1 (QS1)** - Single-adjustable, 16-position knob adjusts bumps and rebound simultaneously
- **QuickSet 2 (QS2)** - Double-adjustable, dual 16-position knobs adjust bump and rebound independently

Front Anti-Roll Bars



Rear Anti-Roll Bars (Adjustable-Rate)

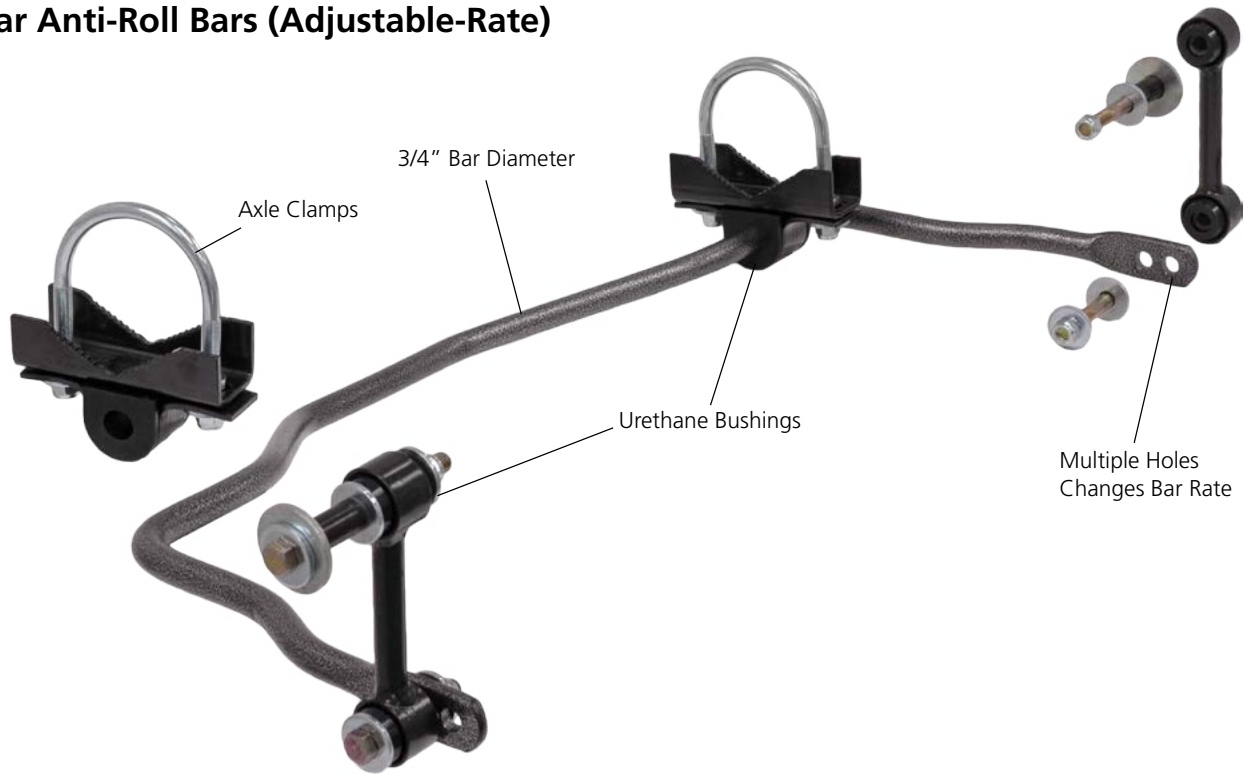

All prices subject to change. Current pricing available at www.totalcontrolproducts.com.



Total Control Products
8661 Younger Creek Drive – Sacramento, CA 95828
A Chris Alston's Chassisworks, Inc., Brand

Order: 800-722-2269
Tech: 916-388-0288
Fax: 916-388-0295

tcpsales@cachassisworks.com
tcpstech@cachassisworks.com
www.totalcontrolproducts.com