

Custom Roll Cage Worksheet Instructions

This custom roll cage worksheet is designed to measure the cage without having to use angles. This will work best with two people, one to hold the half circles and the other to take the measurements. Write all the numbers on a separate piece of paper and then fill in the worksheet after you have double-checked all dimensions.

Fill in your name, car year & model, and sign the worksheet at the top, leave the SO# blank.

SECTION 1 - MEASURING FOR MAIN HOOP

1. Cut a 13-5/8 inch circle out of cardboard, and then cut it in half. Mark the center of the circle because you will be measuring between the center points.
2. Place the first half circle against the headliner and the top of the window on the driver side of the car where you want the main hoop. Leave 1/2" of clearance on the side by the quarter window. The main hoop is installed even with or just behind the B post, or back of the door opening. Place a second half circle on the passenger side of the car in the same position. Be sure the flat side of the half circles are horizontal as shown. Measure from center to center of the half circles and record this as "A".
3. With the passenger side half circle still against the headliner, place a second half circle on the passenger side where you want the center bend of the main hoop to be, leave 1/2" of clearance on the side by the door. This point is normally where the window meets the top of the door. The flat edge of the second half circle needs to be vertical as shown. Measure center to center of the half circles and record this as "B".
4. Do not move the passenger side half circle. Place a half circle across the car on the driver side in the same position, at the top of the door where it meets the glass with 1/2" of clearance. Measure center to center of the half circles and record this as "C".
5. Keeping the passenger side half circle in the same place, put the other half circle flat on the floor and against the passenger side B post, with 1/2" of clearance. Measure center to center of the half circles and record this as "D".
6. Do not move the passenger side half circle. Place a half circle across the car on the driver side in the same position, flat on the floor and against the driver side B post with 1/2" of clearance. Record this as "E".

SECTION 2 - MEASURING FOR CAGE SIDES

You will be taking these measurements from where the main hoop will be located. You can use a straight edge positioned where the main hoop will be. This must be 90 degrees to the rocker panel. These measurements are all taken on the driver side of the car.

7. Place the first half circle at the top of the windshield at the head liner with 1/2" clearance. Make sure the flat edge is horizontal and measure from the center of the half circle to the straight edge. Record this as "F".
8. Do not move the half circle at the top of the windshield. Place the second half circle at the point where you want the second bend of the cage side, with 1/2" of clearance. This is normally at the mid point of the dash. Hold the flat edge vertical, measure center to center of the half circles, record this as "G". The "G" dimension cannot be shorter than 14 inches.
9. Measure from the center of the half circle at the dash to the straight edge, record this as "H".
10. Do not move the half circle at the dash, place the other half circle on the floor with the front edge where you want the cage side to contact the floor. Measure center to center of the half circles, record this as "I".
11. Measure from the center of the half circle at the floor to the straight edge, record this as "J".

SECTION 3 - MEASURING FOR THE CAGE SIDES VIEWED FROM FRONT

10. Measure the outside width of the cage sides at the top of the windshield. Record this measurement as "K".
11. Measure the outside width of the cage sides where the second bend of the cage side is located. The same point you used to position the second half circle in section 2. Record this measurement as "L".
12. Measure the outside width of the cage sides where they meet the floor. Record this measurement as "M".

After double checking all dimensions, enter them on the worksheet. Sign the worksheet and fax it to (916) 388-0295 or mail it to Chassisworks at 8661 Younger Creek Drive, Sacramento, CA 95828.

If you have any additional questions, contact our Technical Department at (916) 388-0288.

(1) MAIN HOOP

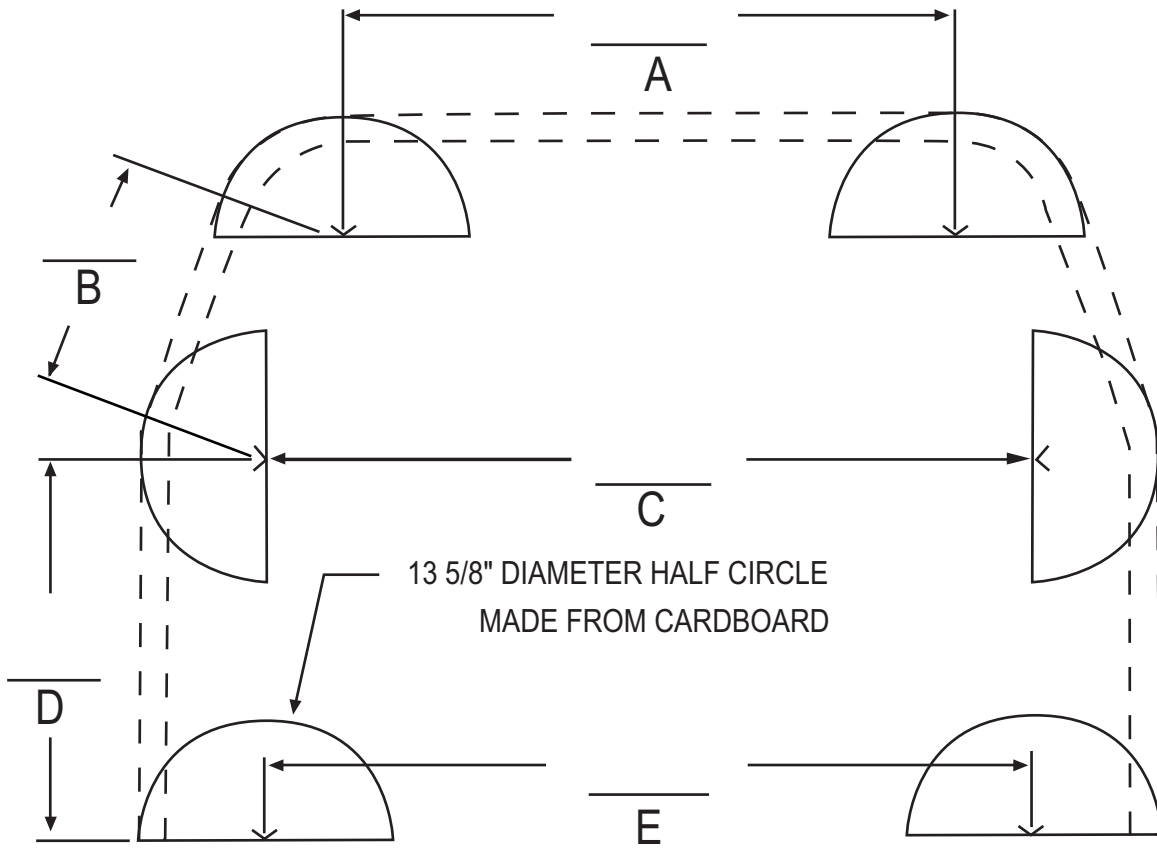

S/O # _____ CUSTOMER _____

I HAVE PROVIDED THESE SPECIFICATIONS FOR MY CUSTOM ROLL CAGE. I ACCEPT RESPONSIBILITY FOR THEIR ACCURACY.

CAR YEAR / MODEL _____ SIGNATURE _____

DATE _____

(2) CAGE SIDES

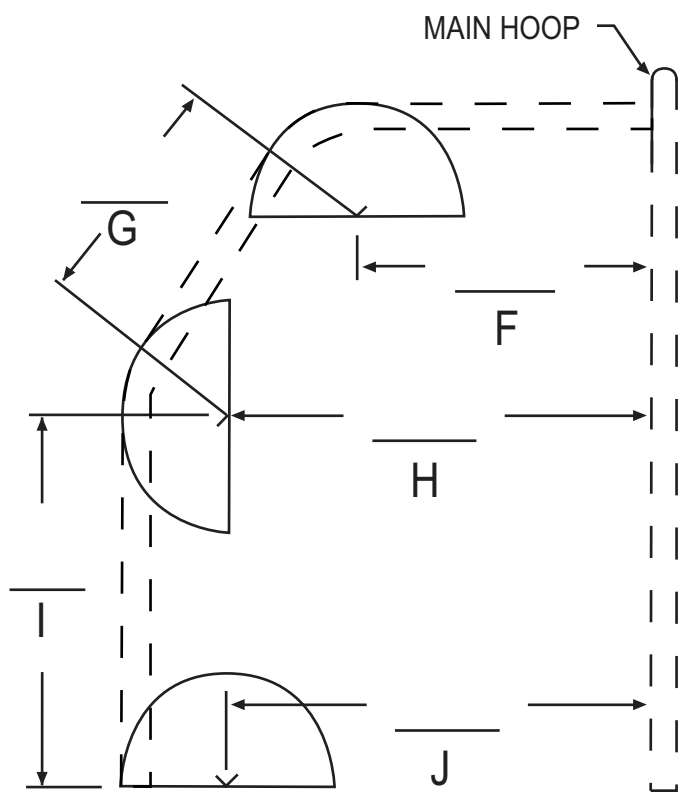

(3) WIDTH OF CAGE SIDES VIEWED FROM FRONT

