

# '79-04 Mustang FAB9™ Housing & Components

Chassisworks' FAB9™ direct fit, fabricated 9" housing offers exceptional performance, reliability, and adjustability. Housing mounts have been engineered to accept OEM or aftermarket control arms and feature multiple mounting positions for instant center adjustment. Shock mounts also have the benefit of multiple mounting positions which enable a ride height adjustment range of over two inches. FAB9™ offers superior strength from fabricated center section panels, internal tube gussets, folded back braces, and consistent robotic spray-arc welded seams.

Various options are also available including; mild steel or 4130 chrome-moly construction, urethane bushing or spherical bearing upper arm mounts, and the drag race ready anti-roll bar and wheelie bar mounting assembly. (Anti-roll bar and wheelie bar kits sold separately.) Housings are available in stock and narrowed widths to a minimum of 56" wheel-to-wheel.

## ■ Urethane Bushing Housing with optional back brace



84MX0-207	URETHANE BUSHING, MILD STEEL HOUSING	\$769.00
84MX0-217	URETHANE BUSHING, CHROME-MOLY HOUSING	1069.00
84MX0-307	SPHERICAL BEARING, MILD STEEL HOUSING	869.00
84MX0-317	SPHERICAL BEARING, CHROME-MOLY HOUSING	1169.00
OPTIONS	MILD STEEL BACK BRACE, INSTALLED	ADD 150.00
	CHROME-MOLY BACK BRACE, INSTALLED	ADD 200.00

## ■ Spherical Bearing Housing with optional anti-roll bar



84MX0-407	URETHANE BUSHING, MILD STEEL, ANTI-ROLL BAR MOUNT, INCLUDES BACK BRACE	\$1069.00
84MX0-417	URETHANE BUSHING, CHROME-MOLY, ANTI-ROLL BAR MOUNT, INCLUDES BACK BRACE	1369.00
84MX0-507	SPHERICAL BEARING, MILD STEEL, ANTI-ROLL BAR MOUNT, INCLUDES BACK BRACE	1169.00
84MX0-517	SPHERICAL BEARING, CHROME-MOLY, ANTI-ROLL BAR MOUNT, INCLUDES BACK BRACE	1469.00

## ■ Anti-roll Bar for FAB9™ Housing - Fox Chassis

The anti-roll bar assembly includes a large 1-1/4" diameter torsion bar with splined ends and billet aluminum arms. Each arm is machined with a single split to ease installation fit, and to clamp down upon the spline when tightened. A socket-head fastener applies pressure to the spline, creating a play-free joint while also fitting into a groove machined at the end of the bar. This locking joint prevents the arms from sliding even

under the most extreme force. Billet arms are connected to the chassis mounts by adjustable length end-link assemblies. Steel end-link tubes feature left and right hand threads, and a 1/2" hex for quick adjustment during installation. Adjuster links feature a 3/8" shank 4130-body rod end for the ultimate in strength.

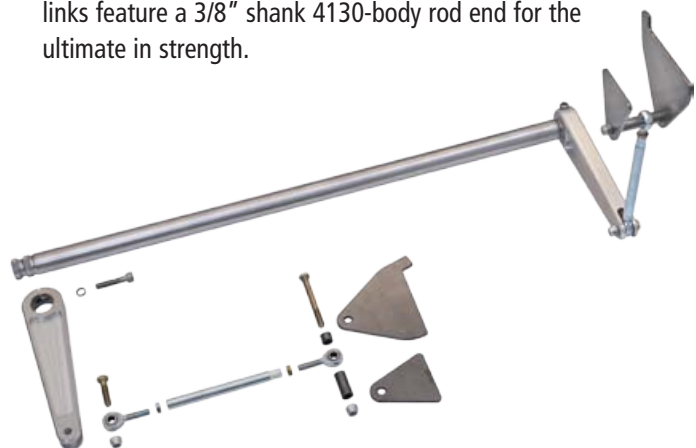
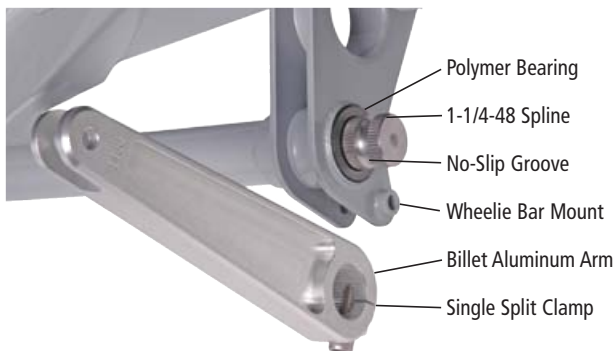

5806-M40	ANTI-ROLL BAR ARMS, LINKS, BRACKETS	\$379.00
----------	-------------------------------------	----------