

Drag Rear Discs



Drag-Race 11.44" Rear Disc Brakes with Forged-Aluminum Four-Piston Calipers



Drilled rotor shown

Red caliper option available

Available with smooth-surface, non-drilled rotors

Drag-Race Rear Disc Brakes

Our drag-race rear disc brake kit features fixed, forged-aluminum, four-piston calipers in black-oxide or red-powder-coat finish and 11.44 x .35" solid or drilled rotors and billet aluminum hats; both finished in black-oxide. The bolt-together hat/rotor assembly allows worn or damaged components to be replaced easily and economically. Our enhanced-friction ceramic-formula brake pads provide smooth engagement with consistent response from a flat torque curve throughout their entire effective temperature range. The kit is available for all standard Ford housing ends and requires 15" or larger wheels. Performance applications should be limited to drag-race vehicles under 2,800 lb. A parachute is also required on any vehicle exceeding 150 mph.

Forged Dynalite Caliper

The Wilwood 11.44" rear disc brake kit uses Forged Dynalite (FDL) four-piston, aluminum, lug-mount calipers for their superior rigidity and enhanced braking performance and pedal feel. The calipers use a closed-end, internal fluid passage design that is further strengthened by four steel bridge bolts extending through the caliper body. Stress-flow forging and smooth surface transitions help eliminate stress points and reduce overall caliper deflection.



Red caliper option available

FDL calipers use one-piece, 1.75"-diameter, stainless-steel pistons and high-temperature, square-faced bore seals. Stainless steel slows heat transfer to the brake fluid and improves the system's resistance to heat-induced pedal fade. This reduction in heat also increases the service life of the fluid and seals. The four individual pistons apply pressure against both sides of the rotor. Caliper fluid requirements are matched to the output capabilities of commonly used factory master cylinders ensuring comfortable performance in a wide range of applications.

Dynalite calipers are trouble-free and service-friendly. Vibration-dampening stainless-steel bridge-plate inserts protect the caliper body from wear caused by pad movement, greatly extending service life. Two-piece bleed screws are easily accessed at each corner of the caliper and eliminate direct wear to the aluminum body. Brake pads are also easily changed by simply removing the retaining pin and sliding the pads out.

Lightweight Performance Rotors

The kit comes standard with black-oxide-coated solid rotors constructed from a special alloy steel known for its high thermal stability and resistance to distortion. These lightweight performance rotors are designed specifically for drag-racing applications under 2,800 lb. Rotors measure 11.44 x .35" and weigh in at a mere 5.4 lb. For more eye-catching performance and reduced weight, a drilled version weighing only 4.7 lb is available.



Billet Aluminum Hat

Separate billet aluminum hats reduce unnecessary weight and allow components to be easily replaced if damaged or worn. Hats use a solid-wall, cylindrical design to improve rotor stability. Their black-anodized finish improves heat dissipation, prevents oxidation, and resists scratching. Rotors and hats are secured by Grade 8, safety-wire-drilled hex bolts in an eight-bolt configuration. Hats come drilled for 1/2" wheel studs on 4-1/2", 4-3/4", and 5" five-lug bolt patterns. Hats for larger 5/8" wheel studs are drilled with 4-3/4" and 5" five-lug patterns.

Applications

Housing Style	Solid Rotor	Drilled Rotor	Offset
	\$487 ^{.95}	\$507 ^{.95}	
Small GM w/ C-Clips	WW 140-0263	WW 140-0263-D	2.81"
Small GM w/ C-Clip Eliminators	WW 140-4545	WW 140-4545-D	2.81"
Small GM Special	WW 140-5771	WW 140-5771-D	2.81"
Small Ford (Early Mustang)	WW 140-0262	WW 140-0262-D	2.66"
Big Ford (Early)	WW 140-0261	WW 140-0261-D	2.36"
Big Ford (Early)	WW 140-3623	WW 140-3623-D	2.50"
Big Ford (Late/Torino)	WW 140-2119	WW 140-2119-D	2.50"
Symmetrical (Lamb / Mark Williams)	WW 140-0265	WW 140-0265-D	2.81"
Symmetrical (Lamb / Mark Williams - .69" Studs)	WW 140-5348	WW 140-5348-D	2.81"
Mopar/Dana Green Bearing	WW 140-0260	WW 140-0260-D	2.36"
Mopar/Dana Green Bearing w/ Span Ring	WW 140-5255	WW 140-5255-D	2.36"
Mopar/Dana Green Bearing w/ Span Ring	WW 140-8853	WW 140-8853-D	2.50"
Olds/Pontiac	WW 140-0264	WW 140-0264-D	2.81"
Olds/Pontiac (.69" Studs)	WW 140-5349	WW 140-5349-D	2.81"

Housing End Diagrams

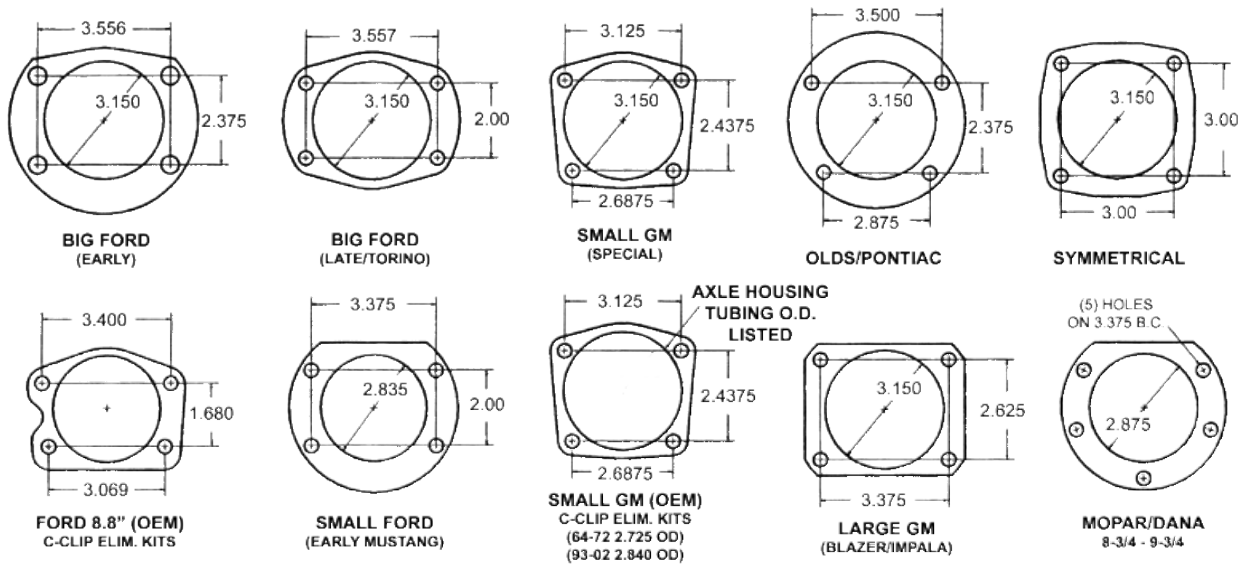

Axle Offset

Axle offset is measured from face of housing end to outside face of axle flange.

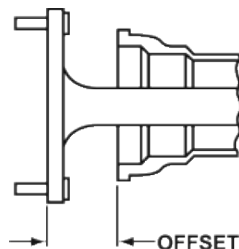

Exploded Diagram

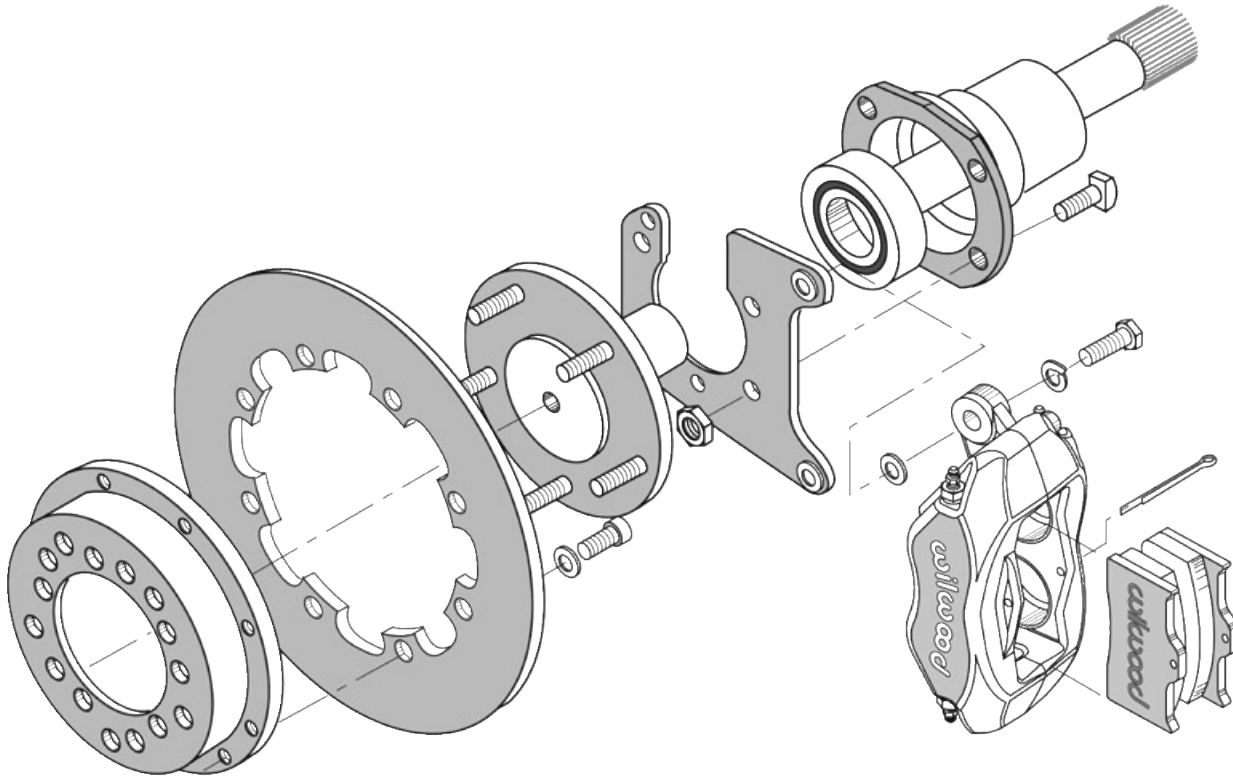

Axle-Flange Clearance

The existing axle-flange contact surface must be no larger than 6.14" to properly seat against the flat of the aluminum hat. Outside flange diameter must be under 6.35".

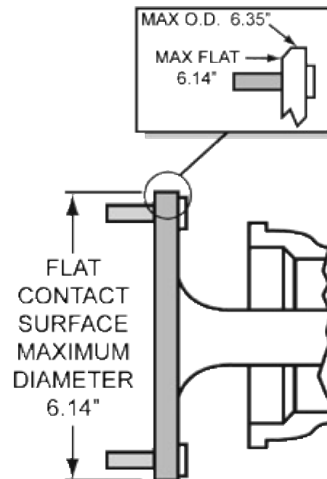

All prices subject to change. Current pricing available at www.cachassisworks.com.



Chris Alston's Chassisworks, Inc.
8661 Younger Creek Drive
Sacramento, CA 95828

Order: 800-722-2269
Tech: 916-388-0288
Fax: 916-388-0295

sales@cachassisworks.com
www.cachassisworks.com