

**Street-Machine Upper and Lower A-Arms
 for g-Machine Crossmember System**



Polished stainless arms (6179 & 6180) shown with optional billet balljoint covers (6173).

Features and Benefits:

- TIG-welded, .156"-wall, tubular construction
- Available in mild- and stainless-steel versions
- Allows use of VariShock coil-over or ShockWave™ air suspension
- Easily replaceable, heavy-duty, screw-in balljoint



Street-Machine A-Arms

Chassisworks' Street-Machine A-arms are designed for performance street vehicles using our g-Machine crossmember system with VariShock coil-overs or ShockWave™ air suspension. Self-lubricated polymer pivot bearings enable predictable handling and effective suspension tuning with very little maintenance, thanks to linear resistance, minimal deflection, and extremely low rate of wear. Press-fit pivot bearings and heavy-duty screw-in balljoints allow the A-arm to be easily rebuilt if ever needed. Street-Machine A-arms are constructed from mandrel-bent, 7/8 or 1 x .156"-wall, mild- or stainless-steel round tubing, creating a lightweight component durable enough for regular performance street use. With the aid of a fixture, tubes are seated into recessed faces along the billet balljoint housing to provide a high-strength, interlocking, TIG-welded joint that angles the balljoint and ensures bind-free operation. Billet balljoint housings feature an exterior groove to enhance appearance and reduce weight.



To improve upon the standard balljoint dust boot's effectiveness, special counter bores are machined into the balljoint housing to capture the rubber seal base, enabling contact along the bottom and outside edges. Three material finish combinations are available: paintable mild steel, black powder-coated mild steel, or polished stainless steel for show-quality appearance that outlasts chrome.

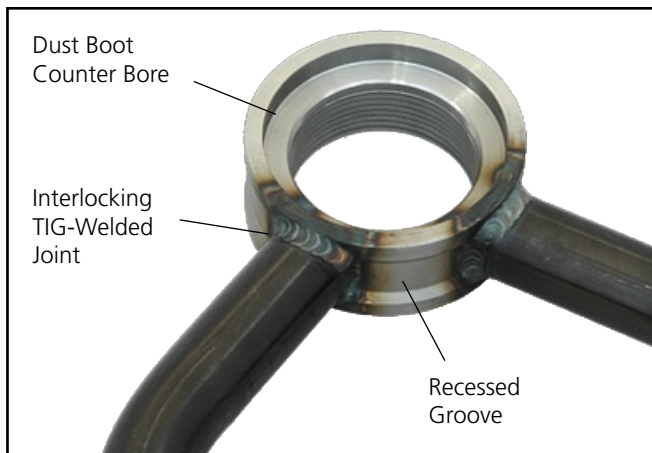

Pivot-Stud Hardware

Specially designed Allen-drive, beveled-head pivot studs thread directly into the g-Machine crossmember to mount the A-arms. Fasteners feature a thread-free 3/4" shank for maximum shear strength and have a broad bearing contact surface that reduces wear. A shoulder at the base of the smaller 5/8" thread creates a positive stop that ensures the correct amount of bearing preload. The shank's seating groove increases contact area with the oval-point set screws used to lock the hardware. Pivot studs are packaged with A-arms in either zinc-plated mild steel or polished stainless steel.

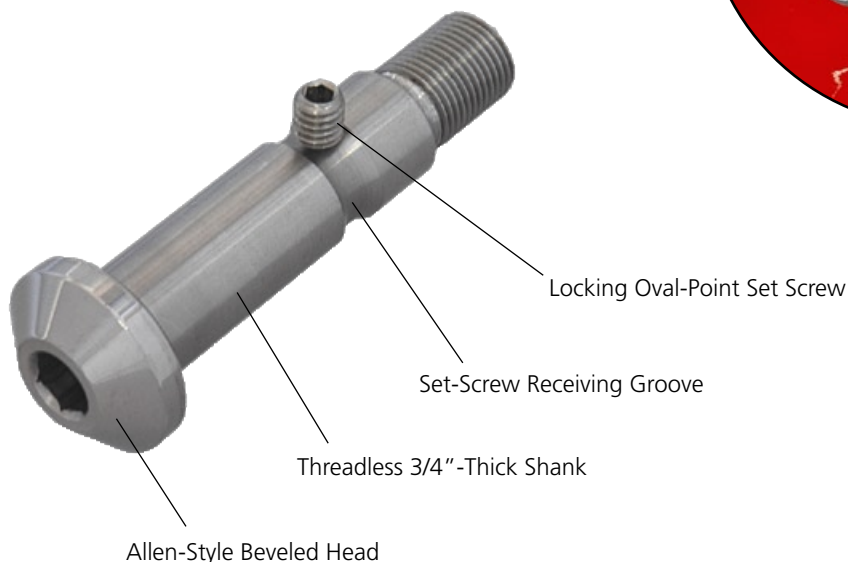
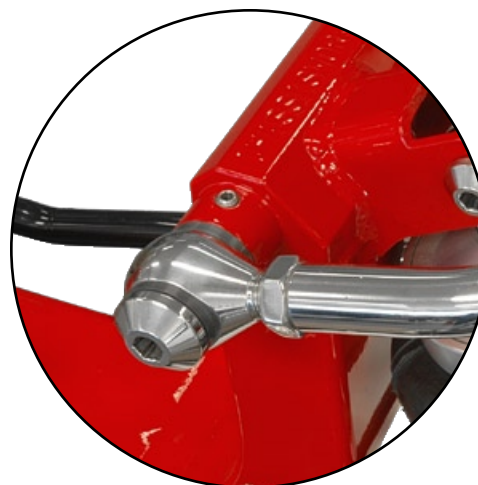

Street-Machine Upper A-Arms

Chassisworks' Street-Machine upper A-arms are constructed from mandrel-bent 7/8 x .156" -wall steel tubing that is TIG-welded to form an open design, allowing clearance for VariShock coil-overs or larger-bodied ShockWave™ air suspension. Our designed suspension system geometry provides positive caster upon installation by offsetting the balljoint rearward, but it can also be further adjusted to compensate for body rake or driver preference. Bearing eyebolts, CNC-machined from steel billets, feature a 5/8" shank to thread directly into the A-arm welded assembly and are secured by jam nuts. This enables highly accurate caster and camber adjustment (approx. 1/8-degree increments) without shims and eliminates the possibility of shifting alignments, which is common with slot- and eccentric-adjusted arms.



6179



6171



6181



6181-SS

Part Number	Description	Price
6171	Street-Machine Upper A-Arms, Plain Mild-Steel Arm, Plated Mild-Steel Hardware (balljoints separate)	\$368. ⁰⁰
6179	Street-Machine Upper A-Arms, Polished Stainless Arm, Polished Stainless Hardware (balljoints included)	739. ⁰⁰
6181	Street-Machine Upper A-Arms, Black Mild-Steel Arm, Plated Mild-Steel Hardware (balljoints separate)	379. ⁰⁰
6181-SS	Street-Machine Upper A-Arms, Black Mild-Steel Arm, Polished Stainless Hardware (balljoints separate)	529. ⁰⁰

Street-Machine Lower A-Arms

Chassisworks' Street-Machine lower A-arms are efficiently designed so that each component contributes to the arm's overall strength and stability. The arms feature 1 x .156"-wall steel tubing, TIG-welded construction and a bracing cross-tube and multiple triangulating gussets consisting of two shock-mount plates and the anti-roll-bar urethane-bushing end-link mount. CNC-machined weld eyes create a stable bushing housing that inserts into each arm tube and gradually tapers to match the outer tubing diameter. This design eliminates fatigue points normally found in other "T"-style tubular bushing-housing joints. Our designed suspension geometry offsets the balljoint forward to improve static positive caster. It also places the shock very close to the spindle in a dropped position for better control with lighter-rate springs and decreased space requirements at the top end of the shock. Lower A-arms pivot points are spread broadly apart, greatly increasing performance while eliminating the need for secondary strut rods.

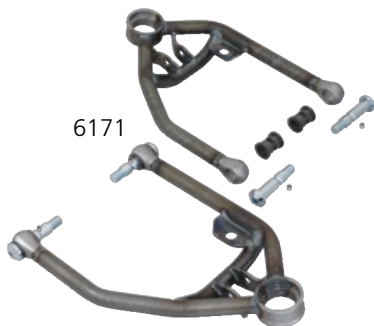

Part Number	Description	Price
6172	Street-Machine Lower A-Arms, Plain Mild-Steel Arm, Plated Mild-Steel Hardware (balljoints separate)	\$539 ⁰⁰
6180	Street-Machine Lower A-Arms, Polished Stainless Arm, Polished Stainless Hardware (balljoints included)	999 ⁰⁰
6182	Street-Machine Lower A-Arms, Black Mild-Steel Arm, Plated Mild-Steel Hardware (balljoints separate)	549 ⁰⁰
6182-SS	Street-Machine Lower A-Arms, Black Mild-Steel Arm, Polished Stainless Hardware (balljoints separate)	599 ⁰⁰

A-Arm Accessories

Billet Balljoint Covers

Polished, stainless-steel balljoint covers are available to add a show-quality finished look to any of our Street-Machine or g-Machine A-arms. Covers mount in place of the zerk fitting using flat-head stainless hardware and meet seamlessly with the A-arms' machined balljoint housing.



Heavy-Duty Screw-In Balljoints

Sold in pairs, these premium screw-in balljoints are compatible with all Chassisworks upper and lower A-arms. Kits include balljoints, rubber dust boots, and hardware.



Balljoint Wrench

Our zinc-plated, laser-cut steel balljoint wrench takes the hassle out of dealing with the uncommon OEM square-drive feature of screw-in balljoints.

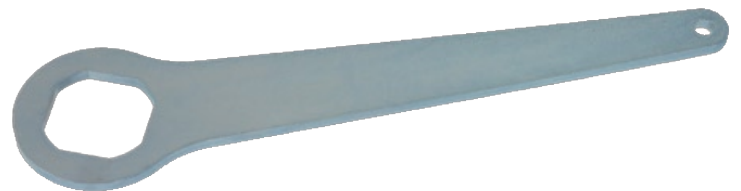

Part Number	Description	Price
6173	Billet Balljoint Covers, Polished Stainless Steel (pair)	\$79. ⁰⁰
6104	Screw-in Balljoints with Boots and Hardware (pair)	54. ⁰⁰
6711	Screw-in Balljoint Wrench, Zinc-Plated Steel	35. ⁰⁰

Notes:

All prices subject to change. Current pricing available at www.cachassisworks.com.



Chris Alston's Chassisworks, Inc.
8661 Younger Creek Drive
Sacramento, CA 95828

Order: 800-722-2269
Tech: 916-388-0288
Fax: 916-388-0295

sales@cachassisworks.com
www.cachassisworks.com