

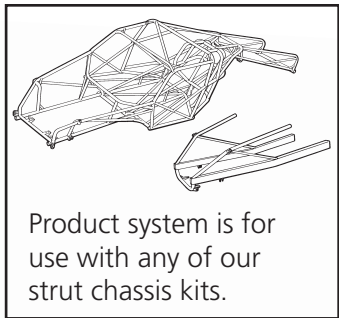

A Chris Alston's Chassisworks, Inc. Brand

## Drag Race Strut System

### VariShock Billet Drag Race Strut Suspension with Integral Spindle



Product system is for use with any of our strut chassis kits.

#### Struts include:

- Billet strut body with integral spindle
- Double-adjustable QuickSet 2 valving
- Light weight brake kit - 2-piston calipers, 10" solid rotors
- Choice of strut travel and spring rate

#### Optionally Available:

- Titanium spindle/base save 5 lbs. a set
- Spindle mount wheel brake kit with slotted rotor and floating caliper for specific models of Weld Racing and American Racing wheels
- Medium-duty brake kit using 4-piston calipers and 11.75" solid rotors
- Slotted rotors available in 10" and 11-3/4" diameter
- Control arms featuring high-misalignment, 5/8"-bore, Teflon-lined, spherical bearing, pivot-stud-bearing housing mechanism; 4130 tubes; and 1/2"- thread tube adapters
- Rod ends are available in two sizes to match 7/16" or 1/2" chassis attachments
- Tie-rod tubes are designed to replace the stock-Pinto-rack tie rod with 5/8"-OD, 4130 tube and high- misalignment rod ends

#### Chassis Mount Styles:

- Clevis chassis mount for spherical bearing eye struts
- Fixed or adjustable-height spherical bearing chassis mount for stem top struts
- Poly pad strut-top chassis mount for stem top struts

### VariStrut Front Integral-Spindle Systems

VariStrut is a new family of racing front struts designed and manufactured in the United States. The CNC-machined strut assembly incorporates all the features of our double-adjustable VariShock. It uses our 1-piece, self-locking lower spring seat. The base is machined out of high-strength stainless steel to incorporate the lower body with the axle. The steering arm, lower A-arm mounting stud, and brake-caliper bracket bolt directly to the base. This compact unit allows us to drop the shock reservoir below the center of the axle. The axle does not press in, which significantly increases available travel. VariStruts are available in 2-1/2" and 4"-travel aluminum-reservoir, and 6"-travel 4130-reservoir configurations. Each strut accepts 2-1/2"-ID VariSprings with a broad range of spring rates from which to choose. VariStruts were designed as bolt-in

replacements for Strange struts to increase your travel by over 1-1/2" to 3-1/2". VariStruts with extended travel are perfect for drag classes restricted to smaller tires. They provide more front suspension travel to increase weight transfer. Available with stud or eye upper mounts. The eye mount uses a spherical bearing (COM-8 Teflon®-lined 1/2" bore x 1-1/8" wide). VariStrut offers excellent weight transfer, high-speed stability, and ease of installation for a lightweight front suspension.

Installation is eased with our 2-piece, spherical-bearing control arm. With a lower 4140 pivot on the strut, the control arm adjusts to set camber and caster. The ride height is set using our lower spring seat. The upper mount can be an 11/16" stem or a spherical COM-8 bearing. The damping is adjusted by two knobs on the lower body. Positioned away from the wheel and brake disc for easy access.

VariStrut is a double-adjustable strut with 16-step adjustments on both bump (compression) and rebound (extension). This allows for an unprecedented 256 combinations of control. The double-adjustable strut allows you to independently set how the car separates for weight transfer and how fast it settles down the track.

### Lower Control Arms

Control arms are built from 1"-OD 4130 tubing with 1/2"-thread weld-in tube adapters.

A high-misalignment, 5/8"-bore, Teflon®-lined, spherical bearing is housed in a specialized tube adapter that connects to the two arm lengths with the strut's pivot stud. Half-inch shank, Teflon®-lined, 4130 rod ends are available in two different bore sizes to match the most common chassis mounts; 7/16" or 1/2".

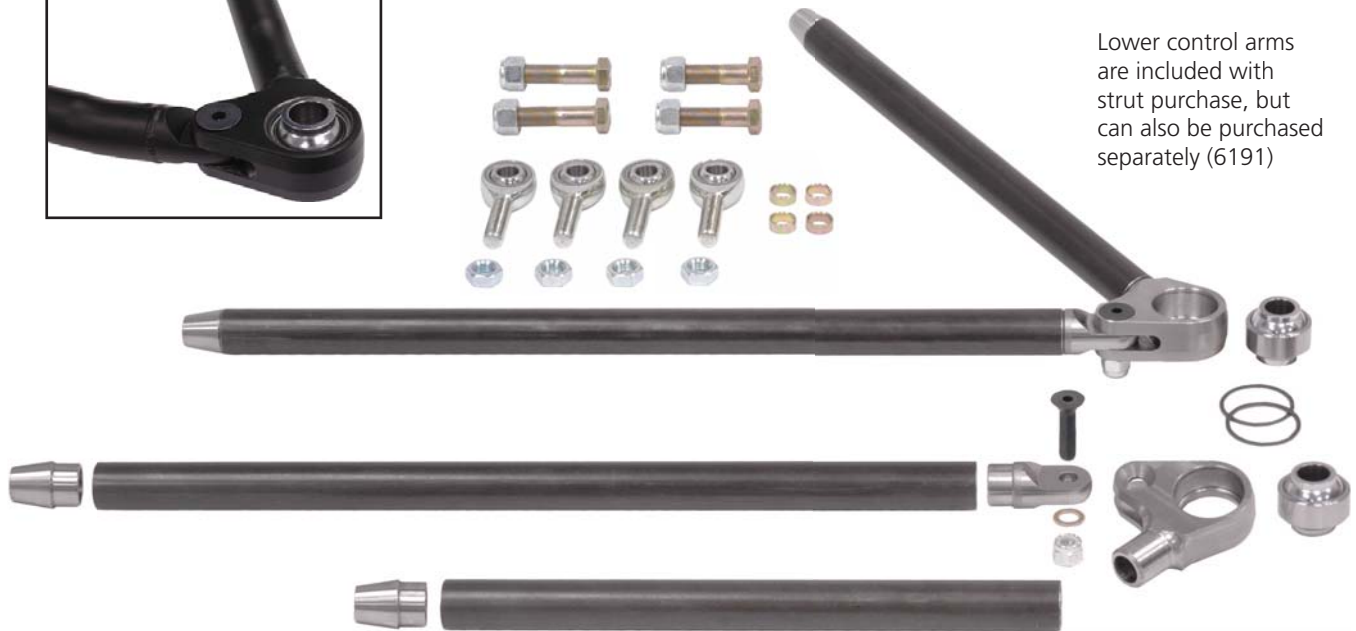

Lower control arms are included with strut purchase, but can also be purchased separately (6191)

## Billet VariStruts

To take full advantage of Chassisworks' advanced manufacturing capabilities, a complete custom bolt-on strut was developed. Installed height, travel, valving range and mounting configuration are built to our exact specifications, whereas other manufactures are forced to compromise with "off-the-shelf" products. Billet VariStruts feature double-adjustable valving, a selection of upper chassis mounting styles, including fixed- or adjustable-height spherical-bearing stem mounts, spherical-bearing clevis mounts, or urethane bushing mounts and 6" of suspension travel; ideal for restricted tire-size racing classes. The dual 16-position valve-adjustment knobs allow you to precisely tune the rate of weight transfer at launch and how the chassis settles down track.

## Double-Adjustable 16-position Knobs

VariShock's QuickSet 2 double-adjustable valve mechanism enables independent bump and rebound adjustment for the ultimate in tuning vehicle launch characteristics. Simply by rotating two fully accessible 16-position knobs 256 different settings are attainable. Adjustments are made in seconds without tools or the need to remove or unbolt the strut. Each knob is laser-etched with directional arrows and "plus/minus" symbols to clearly indicate which direction achieves the desired adjustment. Additional arrows etched into the strut's base reveal which knob sets bump, and which sets rebound.

## Locking Lower Spring Seat

A new-design, one-piece lower spring seat does not require a lock nut; it's locked in place by two ball locks that press into the grooves on the reservoir body and easily unlock with an Allen wrench for adjustment.

## Revolutionary Strut Body

Our billet alloy-steel strut body features an integrated spindle as opposed to a press-in spindle component. This exclusive manufacturing method frees up valuable space and allows the reservoir to be moved downward, behind the spindle. Within the spindle base is a revolutionary adjustment mechanism that is packaged tighter than any previous design. The net result is 6" of suspension travel without increasing the overall height of the strut. "Deflective Disk Valving" is used to eliminate spring fatigue. Piston rods are made from 7/8" centerless ground hard chrome steel for wear resistance and long service life.

## Strut Tubular Tie-Rod Assemblies

Tie-rod tubes are designed to replace the stock-Pinto-rack tie rod with 5/8" -OD, 4130 tube. A 7/16" thread on the outboard end attaches a 3/8" -bore, high-misalignment, 4130-body, Teflon®-lined rod end to be used as a tie-rod end. The strut steering arm is attached to the rod end with the provided hardware and bump-steer shims.



|      |                                                     |          |
|------|-----------------------------------------------------|----------|
| 6194 | Tie-rod tubes, 3/8 x 7/16",<br>4130 rod ends (pair) | \$139.00 |
|------|-----------------------------------------------------|----------|

## Systems Include:

- 2-1/2", 4", or 6" travel reservoir body with integral-spindle, high-strength, stainless-steel strut base
- Choice of top mount styles (stem or stud)
- QuickSet 2 double-adjustable shock valving
- Choice of spring rate
- Lower control arm components (rod ends optionally included)
- Hub- or spindle mount brake kit (various upgrade options available)

## ■ Eye-Mount 4" Travel Strut

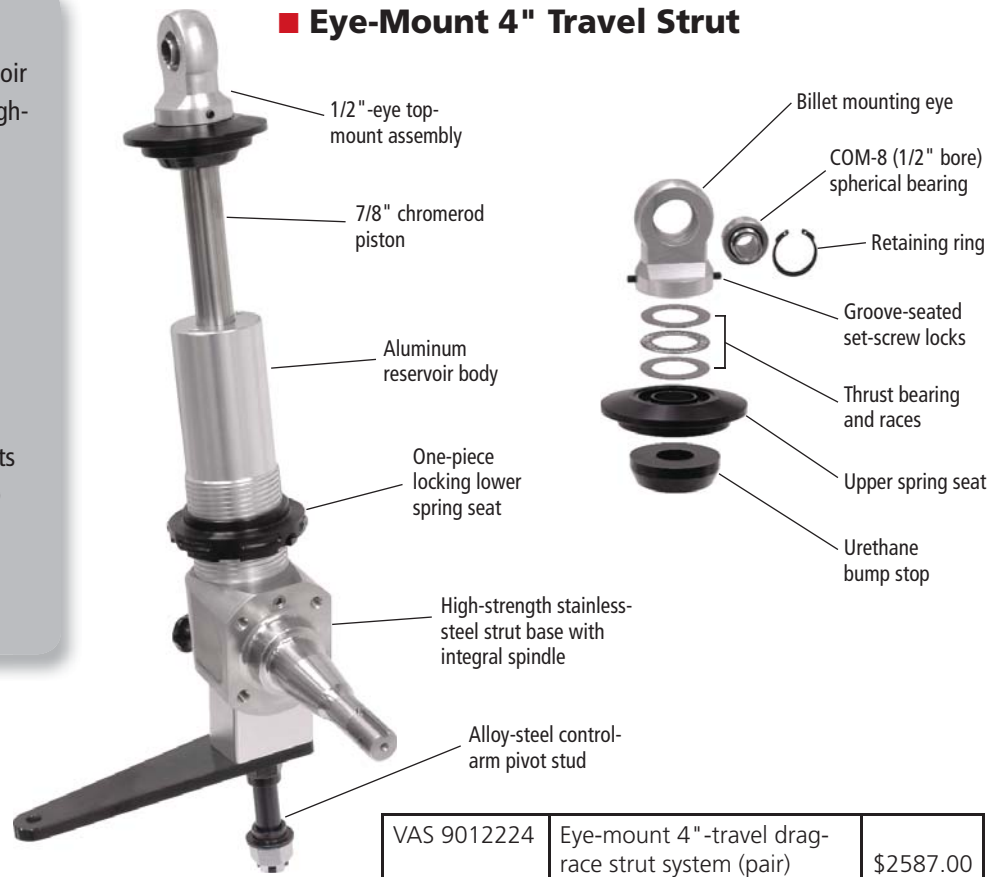

## ■ Stem-Mount 4" Travel Strut

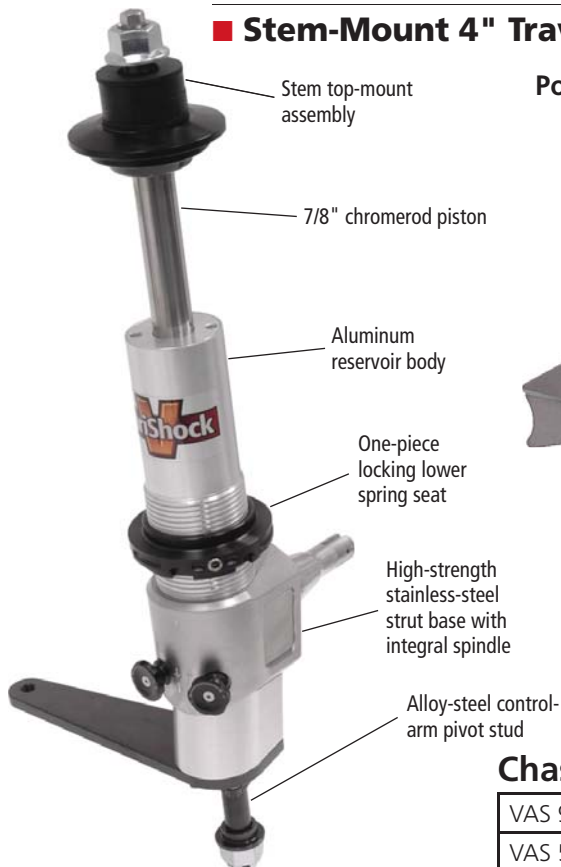

### Poly-Pad Mount

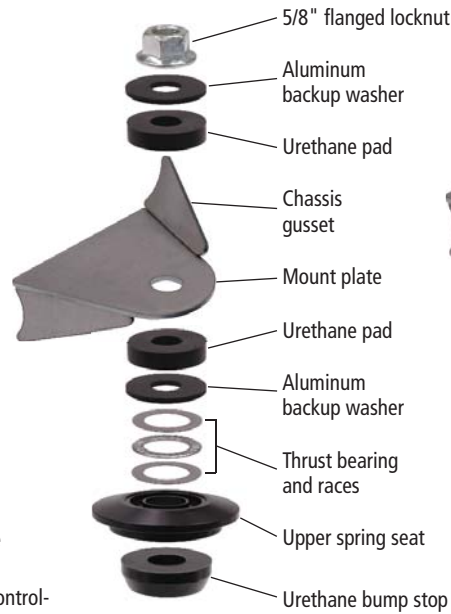

### Spherical-Bearing Mount

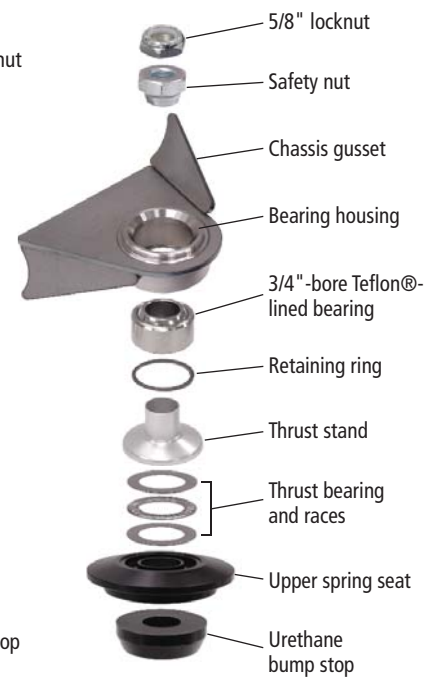

## Chassis Mounts - 4" Travel Struts

|              |                                                    |           |
|--------------|----------------------------------------------------|-----------|
| VAS 9012124  | Stem-mount 4"-travel drag-race strut system (pair) | \$2587.00 |
| VAS 505-100  | Poly-pad, strut-top chassis mount                  | 39.00     |
| VAS 505-101  | Spherical-bearing chassis mount for stem top       | 159.00    |
| <b>NOTE:</b> | Mounts also fit Strange stem-mount struts          |           |

## ■ 2-1/2" Stem-Mount Strut

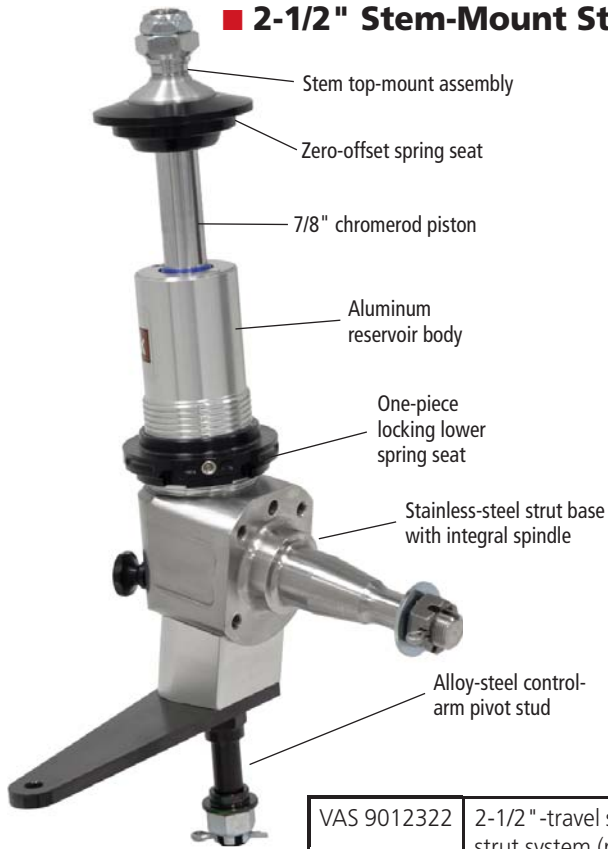

## ■ 6" Stem-Mount Strut



|             |                                              |           |
|-------------|----------------------------------------------|-----------|
| VAS 9012322 | 2-1/2"-travel stem-mount strut system (pair) | \$2587.00 |
| VAS 9012326 | 6"-travel stem-mount strut system (pair)     | 2879.00   |

## ■ Stem-Style Bearing Chassis Mounts

### Fixed Mount

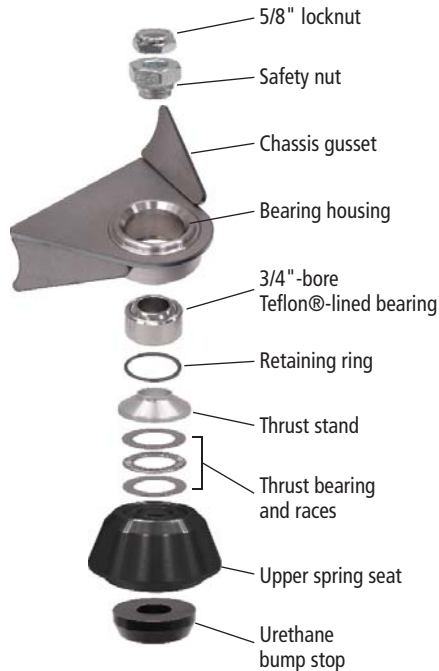

### Adjustable Mount

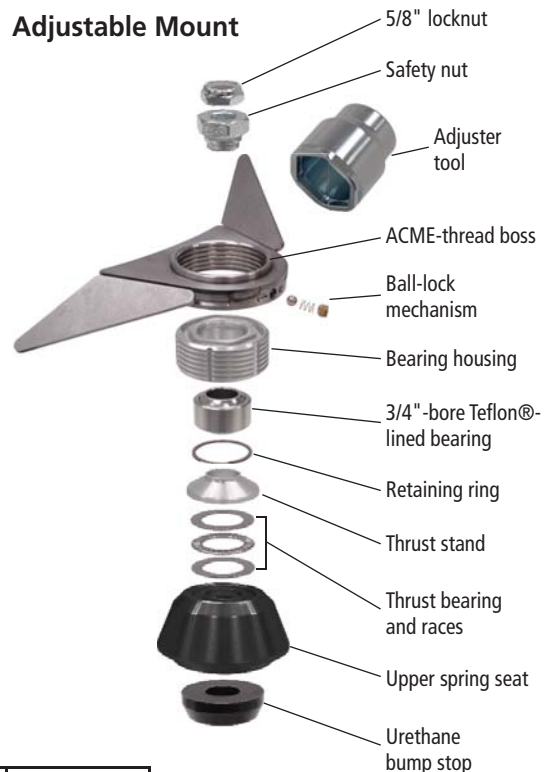

## Chassis Mounts - 2-1/2" and 6" Travel Struts

|             |                                        |        |
|-------------|----------------------------------------|--------|
| VAS 505-102 | Fixed position COM-12 chassis mount    | 159.00 |
| VAS 505-103 | Adjustable height COM-12 chassis mount | 259.00 |

## VariStrut Brake Options

Standard brake options include billet aluminum single-piston floating calipers with 10-1/4" rotors for spindle-mounted wheels or dual-piston fixed calipers with 10" rotors for hub-mounted wheels. A four-piston forged-aluminum caliper with 11-3/4" rotor option is also available for heavier vehicles. Optional slotted rotors can be selected to further reduce weight.

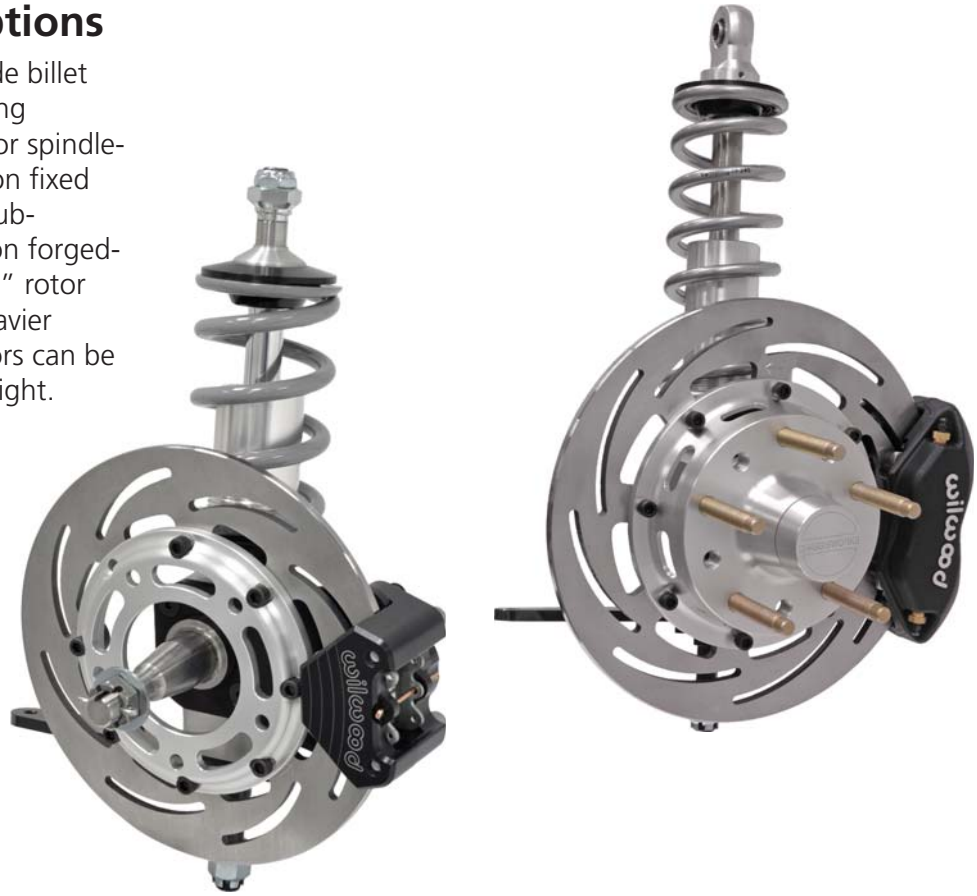

## Spindle-Mount Brakes

- **Caliper:** Billet aluminum, single-piston, floating caliper (black anodized)
- **Rotor:** 10.25 x .25", slotted rotor
- **Hat:** Billet aluminum, silver-anodized finish
- **Fits:**
  - Weld Racing Wheels
    - Alumastar 2.0 (788-15001)
    - Magnum Pro (786-15001 or 786P-15001)
  - American Racing Wheels
    - Torq Thrust® Pro (48553S)
    - TrakStar (48053SBC or 48053S)

## OPTION - Spindle-Mount Brakes

Brake set for spindle-mount wheels (included with strut)

Included



## Light-Duty Brakes

- **Caliper:** Billet aluminum, dual-piston, fixed caliper (black anodized)
- **Rotor:** 10.00 x .35", solid (optional slotted rotor shown)
- **Hub:** Billet aluminum, silver-anodized finish, 4-1/2" and 4-3/4" 5-lug patterns

### OPTIONS - Light-Duty Brakes

|                                       |                 |
|---------------------------------------|-----------------|
| Solid 10" rotor (included with strut) | <b>Included</b> |
| Slotted 10" rotor                     | add \$20.00     |



## Medium-Duty Brakes

- **Caliper:** Forged aluminum, four-piston, fixed caliper (black anodized or optional polished finish)
- **Rotor:** 11.75 x .35", solid (optional slotted rotor shown)
- **Hub:** Billet aluminum, silver-anodized finish, 4-1/2" and 4-3/4" 5-lug patterns

### OPTIONS - Medium Duty Brakes

|                                         |             |
|-----------------------------------------|-------------|
| Solid 11.75" rotor, black calipers      | add \$50.00 |
| Slotted 11.75" rotor, black calipers    | add 70.00   |
| Solid 11.75" rotor, polished calipers   | add 155.00  |
| Slotted 11.75" rotor, polished calipers | add 175.00  |



## High-Travel VariSprings

VariSpring's line of coil springs was designed to complement the VariShock family. A new high-tensile wire is used that is stronger than the chrome-silicon wire used by other manufacturers. The improved material allows VariSprings to compress until the coils touch without damaging the springs or causing them to take a set, which adversely affects handling and randomly changes the spring height. This additional range of usable flex gives VariSprings greater travel than competitors' chrome-silicon springs of the same rate and permits the use of a more aggressive coil angle, reducing material used and overall weight. VariSprings can improve suspension control and available traction by allowing your shock to operate throughout its entire travel range.

VariSprings are available for front and rear applications in various lengths and a broad range of spring rates to suit a variety of shock and performance applications. Lengths range from 6 to 14 inches and rates from 80 to 850 pounds per inch, depending upon spring length. The steps between rates are approximately 15%, sufficiently close to make very fine adjustments.

Springs are manufactured to tight tolerances to ensure uniform performance from every set. Inside diameters are 2.5" and can be used with VariShock coil-over shocks as well as shocks from other manufacturers. Ends are closed and ground to within 1.5 degrees. Springs are dyno-tested and must be within 3% of the designed rate to pass our strict quality control. VariSprings are sold in matched pairs. For universal quality appearance and easy identification, springs are completely powder-coated silver with the part number and spring rate silk-screened along the outside of the coil.

### Baseline Spring Rate Selection

Spring rate affects ride quality, ride height, stored energy, weight transfer and how effectively the front suspension handles downward movement after drag race launches. Differences in vehicles such as specific performance application, weight reduction and chassis stiffening should be taken into consideration. Additional springs can be purchased for tuning purposes. The recommended spring rates are based on the combination of weight of the car and baseline ride height.

Additional information regarding ride height and spring rate selection is available by downloading the Installation and Tuning Guide from the VariShock product document library. The document library contains application charts, data sheets, instructions, and catalog pages for the entire VariShock product line.

<http://www.VariShock.com/docs>



### 2-1/2" Travel Strut - 6" Coil-Spring Rate Baseline

| Front Vehicle Weight (lb) | Rate (lb/in) | Spring Travel (in) | Maximum Preload (in) | Part Number  |
|---------------------------|--------------|--------------------|----------------------|--------------|
| 1175-1550                 | 500          | 3.62               | 1.00                 | VAS 21-06500 |
| 1300-1800                 | 550          | 3.56               | 0.94                 | VAS 21-06550 |

### 4" Travel Strut - 9" Coil-Spring Rate Baseline

| Front Vehicle Weight (lb) | Rate (lb/in) | Spring Travel (in) | Maximum Preload (in) | Part Number  |
|---------------------------|--------------|--------------------|----------------------|--------------|
| 900-975                   | 180          | 5.70               | 1.58                 | VAS 21-09185 |
| 975-1125                  | 210          | 5.64               | 1.52                 | VAS 21-09210 |
| 1125-1275                 | 240          | 5.57               | 1.45                 | VAS 21-09240 |
| 1275-1475                 | 275          | 5.46               | 1.34                 | VAS 21-09275 |
| 1475-1650                 | 310          | 5.57               | 1.45                 | VAS 21-09310 |
| 1650-1800                 | 350          | 5.17               | 1.05                 | VAS 21-09350 |

### 6" Travel Strut - 12" Coil-Spring Rate Baseline

| Front Vehicle Weight (lb) | Rate (lb/in) | Spring Travel (in) | Maximum Preload (in) | Part Number  |
|---------------------------|--------------|--------------------|----------------------|--------------|
| 675-775                   | 80           | 8.63               | 2.76                 | VAS 21-12080 |
| 775-900                   | 95           | 8.28               | 2.41                 | VAS 21-12095 |
| 900-1025                  | 110          | 7.91               | 2.04                 | VAS 21-12110 |
| 1025-1175                 | 130          | 8.43               | 2.56                 | VAS 21-12130 |
| 1175-1350                 | 150          | 7.61               | 1.74                 | VAS 21-12150 |
| 1350-1500                 | 175          | 7.60               | 1.73                 | VAS 21-12175 |
| 1500-1825                 | 200          | 7.45               | 1.58                 | VAS 21-12200 |
| 1825-2200                 | 250          | 7.00               | 1.13                 | VAS 21-12250 |
| 2200-2600                 | 300          | 7.07               | 1.20                 | VAS 21-12300 |

## Fluid Control

A combination of fatigue-resistant deflective-disk and adjustable poppet valves focus damping forces at a range useful to the widest variety of vehicle types and performance applications. Damping-force ranges differ depending upon the adjustment features and mounting configuration of the shock. Custom valve sets are also available to alter the adjustment range of compression or rebound independently. VariShocks provide digressive damping to permit finer adjustment at the higher range of piston speeds (6-12 in/sec) that control rapid suspension movement and ride harshness. To give better control of vehicle-handling without rapidly increasing ride harshness, rebound (extension) valving is purposely stiffer with a broader adjustment range.

## VariShock Quality

Delivering a finished product that is of excellent quality and value is the primary focus throughout the VariShock product line. Unlike other brands in this price range, VariShocks are engineered, manufactured, and assembled in America using state-of-the-art engineering workstations and computer-numeric-controlled (CNC) manufacturing equipment. Each component, including valves, adjusters, and internal shaft seals is designed and manufactured specifically for use in VariShock products. This level of clean-sheet engineering is the first step to producing longer lasting seals that keep dirt out of the shock absorber and extend service life between rebuilds.

Assembly of the components is equally important to delivering a quality product. To avoid the possibility of manufacturing debris contaminating the shock fluid and seals, the VariShock assembly clean room is housed in a completely separate facility. After assembly, each shock is thoroughly dyno-tested and calibrated to meet VariShock's strict performance goals. This ensures virtually identical performance from every pair throughout their entire range of travel. By carefully controlling engineering, manufacturing, assembly, and final testing, VariShock can confidently deliver the highest-quality product with the most value for our customers.

## Adjustable QuickSet Series

The VariShock QuickSet series allows you to easily tune your suspension for improved cornering and acceleration traction, or to quickly adapt to current track conditions. Adjustment takes only a few seconds and is made with the VariShock installed on the vehicle. Readily accessible, 16-position adjustment knobs can be operated by hand or with the aid of a common allen wrench.

The QuickSet 2 valve system features dual adjustment knobs that independently control bump- and rebound-damping stiffness of the shock. Dual-arrow symbols engraved into the shock body demonstrate the function of each knob. Arrows pointing toward each other designate bump (compression) adjustment; the shock collapsing. Arrows pointing away from each other represent rebound (extension) adjustment; the shock extending. Knobs are clearly etched indicating the correct direction of rotation to decrease (-), or increase (+) damping stiffness. There are 16 specific adjustment positions for each knob, with a total of 256 unique combinations possible.



| Symbol | Direction                      | Effect             |
|--------|--------------------------------|--------------------|
| +      | Clockwise                      | Increase Stiffness |
| -      | Counter-Clockwise              | Decrease Stiffness |
| ↓<br>↑ | Bump (compression) Adjustment  |                    |
| ↕      | Rebound (extension) Adjustment |                    |

Position 1, the softest setting, is found by turning the knob in the counter-clockwise direction until the positive stop is located. Rotating the knob in the clockwise direction increases damping stiffness. Each of the 16 settings is indicated by a detent that can be felt when turning the knob, and an audible click as the knob gently locks into position. Only very light force is necessary to rotate the knob past each detent. If access to the adjustment knobs is limited, a 5/64 or 7/64 (depending upon model) ball-drive Allen wrench can be used to adjust the knob.

Note: VariShocks have a substantial range of adjustment with very little bypass or internal bleed. Due to our minimal-bleed design, shocks will feel extremely stiff at some settings when operated by hand, whereas other shocks with excessive bleed will move more freely. Manual comparison should not be performed. A person cannot manually operate the shock at a rate anywhere near real life conditions and any results found in this manner will be meaningless. Prior to shipping, every VariShock is dynamometer (dyno) tested and calibrated throughout an accurate range of shaft speeds and cylinder pressures found in real-world operation.

## VariStrut Dyno Graph

A shock dyno graph displays how much force is required to compress or extend the strut over a range of piston speeds (Force vs. Absolute Velocity). For readability purposes, the following graph only plots response curves for every other adjustment setting of the Bolt-In QuickSet 2 VariStrut. The strut's digressive valving curve can be easily identified by the steeper incline in the slowest piston speeds and more level response as piston speed increases. Each setting provides an even increase of stiffness in relatively even increments across the entire range without deviation from the general response curve. This consistency can be found throughout the VariShock product line and makes suspension tuning simple and intuitive.

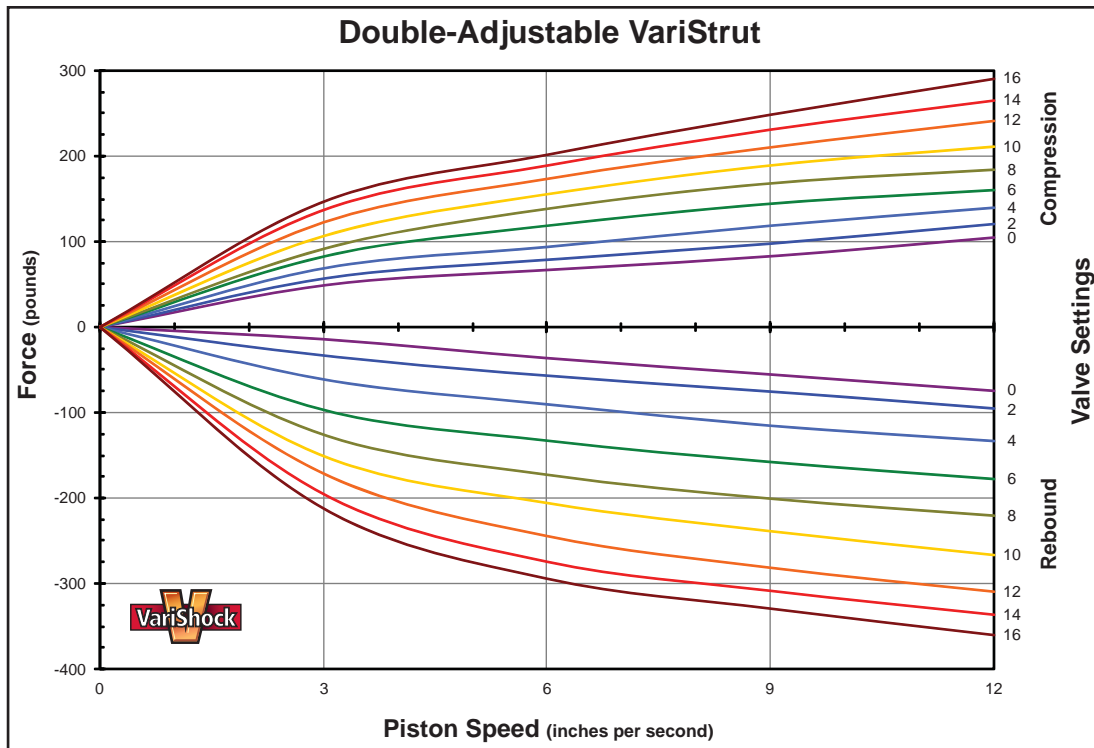

## The Truth About 16- vs. 24-Clicks

Don't be fooled by shocks offering more adjustment clicks. They are actually 1/2-click adjustments. The manufacturer merely added more detents to the mechanism without increasing the range of adjustment. This practice gives more clicks, but the adjustment is so slight that your vehicle will not respond to the change. A 16-position VariShock actually has a broader range of adjustable force with the added benefit of a more manageable number of adjustments to try.

## VariStrut Suspension Front Clips

### Drag Race Strut 1-5/8" Front Frame Clip and Suspension

Made out of 1-5/8 x .134"-wall mild steel or 1-5/8 x .083"-wall 4130 tubing. Kit allows you to lower the front of your drag race car and take off 200 to 300 pounds of unwanted weight. Ground clearance is 3-1/2" at the firewall. The frame rails are long enough to extend from under the car to the rear frame crossmember. Designed for eye-mount VariStruts or Strange struts. Kit includes a pair of frame rails; forward struts to attach to your roll cage; tube rack-and-pinion mount crossmember; upper strut mount tabs; lower control arm mount tabs; hardware; drawing and instructions. Shipped unassembled by UPS.

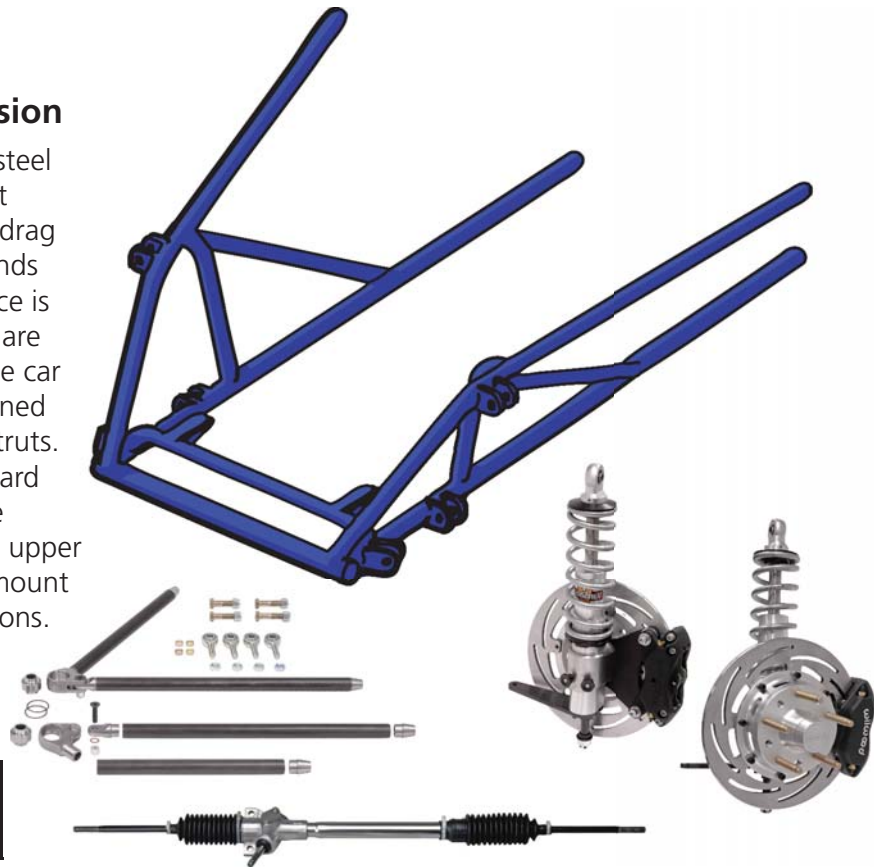

|        |                                                         |           |
|--------|---------------------------------------------------------|-----------|
| 78T923 | 1-5/8" Round Tube Front Frame Clip and Sturt Suspension | \$2998-up |
|--------|---------------------------------------------------------|-----------|

### Drag Race Strut 3x2" Front Frame Clip and Suspension

Made out of 2x3x.083" wall mild steel tubing. These mandrel bent frame rails do not have the ugly wrinkles under the bends like other manufactures. Kit allows you to lower the front of your drag race car and take off 200 to 300 pounds of unwanted weight. Ground clearance is 3-1/2" at the firewall. The frame rails are long enough to extend from under the car to the rear frame crossmember. Designed for eye-mount VariStruts or Strange struts. Kit includes a pair of frame rails; forward struts to attach to your roll cage; tube rack-&-pinion mount crossmember; upper strut mount tabs; lower control arm mount tabs; hardware; drawing and instructions. Shipped unassembled by UPS.



|        |                                                       |           |
|--------|-------------------------------------------------------|-----------|
| 78S923 | 3 x 2" Box Tube Front Frame Clip and Sturt Suspension | \$2998-up |
|--------|-------------------------------------------------------|-----------|

## Related Product

### Bolt-On Drag-Race Chevy II Strut Clip

Reduce front-end weight with our extremely lightweight strut suspension system (124 lb as shown); designed as a direct bolt-on for '62-'67 Chevy II drag race vehicles. The clip attaches to the car using the factory lower-frame and firewall mounts. Our front clips are completely factory-welded and built from 1-5/8 x .083" 4130 round tubing to create additional engine-bay room for tall-deck engines, large-diameter headers, and custom plumbing. The packaged system includes the factory-welded frame clip (bare steel), double-adjustable billet VariStruts, tubular control arms with 4130 rod ends, billet-aluminum drag-race rack, billet rack clamps, bumpsteer-adjustable tie-rod ends, and complete disc-brake set with billet hubs, lightweight rotors and Wilwood aluminum calipers.

### Features

- Lightweight 4130 tubular design
- Double-adjustable strut valving
- Complete bolt-on installation
- 6"-travel billet VariStruts
- Extended-travel billet rack and pinion provides sharper turning radius
- Optional bumper/core-support mounts available

**Only 124 pounds!**

(As shown below)

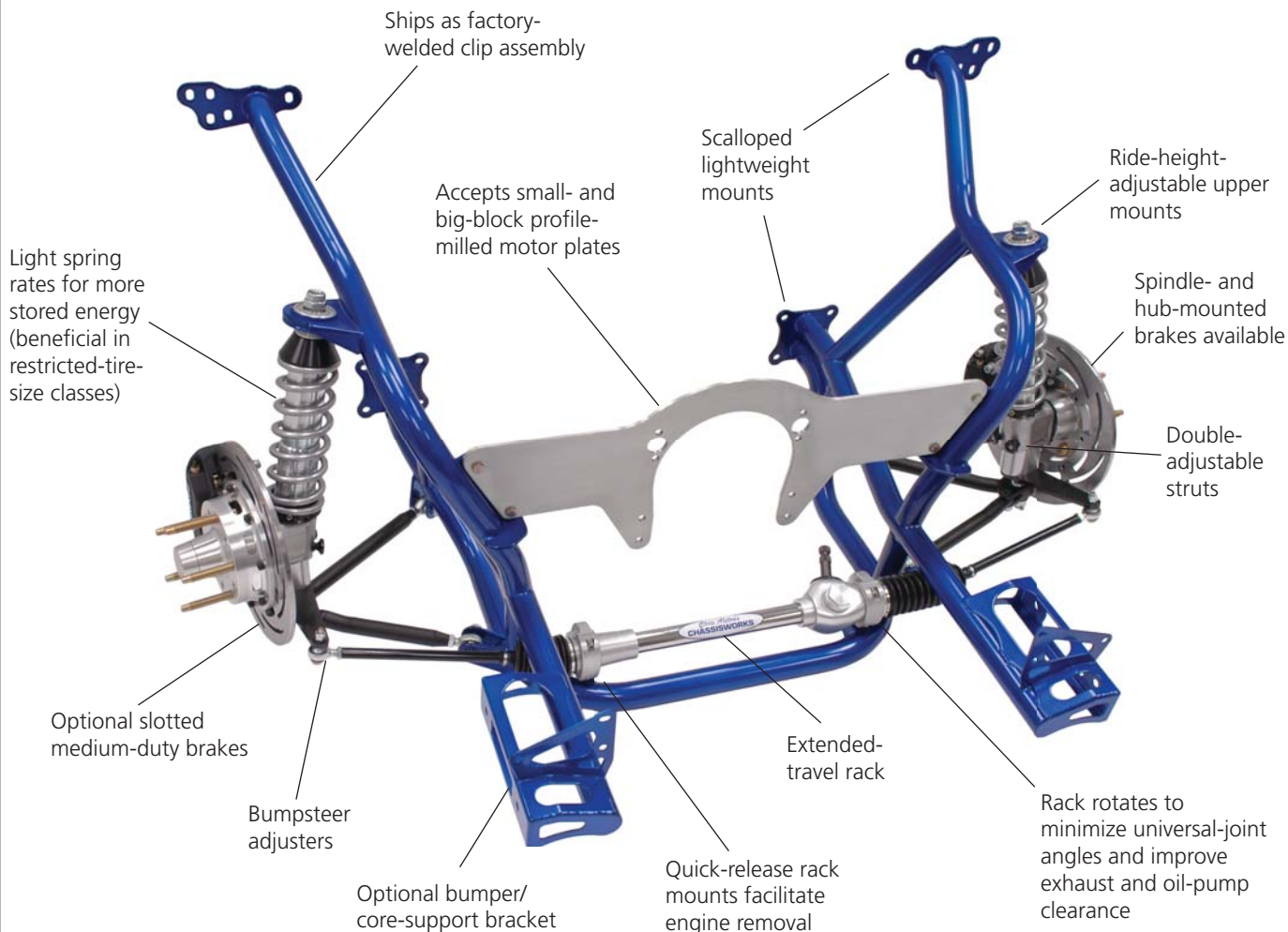

All prices subject to change. Current pricing available at [www.varishock.com](http://www.varishock.com).



A Chris Alston's Chassisworks, Inc. Brand

VariShock  
8661 Younger Creek Drive  
Sacramento, CA 95828

Order: 800-722-2269  
Tech: 916-388-0288  
Fax: 916-388-0295

[varishock@cachassisworks.com](mailto:varishock@cachassisworks.com)  
[www.varishock.com](http://www.varishock.com)