



**Features and Benefits:**

- Front-steer power rack and pinion
- Direct bolt-on for 30" and 33" g-Machine crossmember systems; includes Chevy II and Camaro subframes
- Rotatable within mounts to aid steering-shaft clearance
- Black powder-coat or chrome finish

**g-Machine Power Rack and Pinion**

The g-Machine front-steer power rack and pinion provides responsive steering with excellent driver feedback as a direct bolt-on for Chassisworks g-Machine 30", 33", Chevy II, and Camaro crossmember systems. To increase durability, performance, and reduce deflection, the rack body, control servo, and hard lines are constructed from steel. Hard lines are routed tightly against the rack body and low-profile, rotatable banjo fittings are used exclusively at the control servo to better package the rack for installation.

Note: Chevy II (7700) use 6140-215-X, Camaro (7701) use 6140-245-X

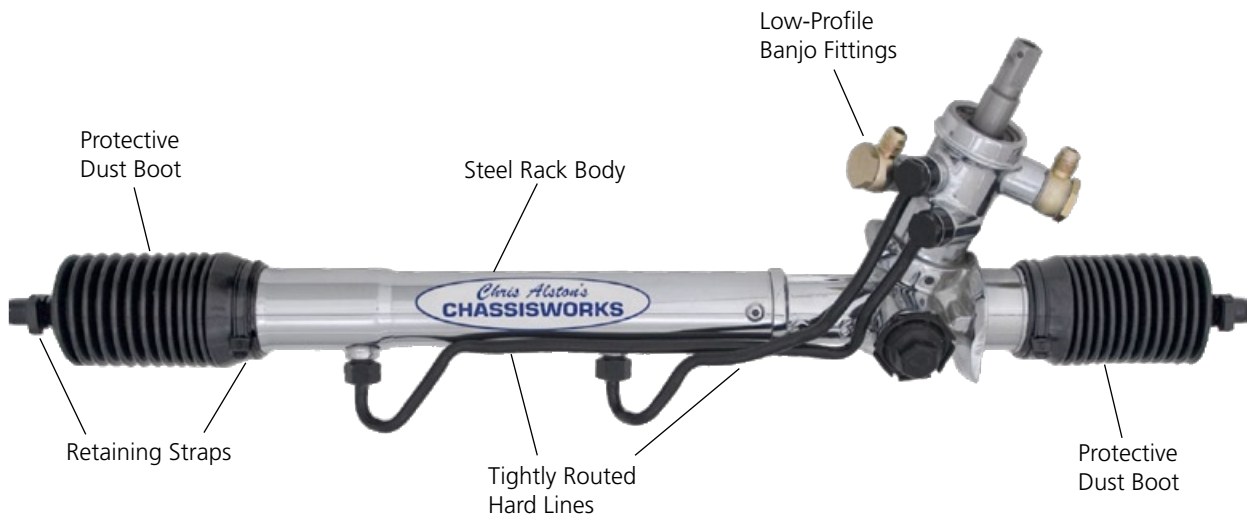

### Rack Clamp Mounting System

Our unique clamping installation method enables the rack to be rotated within its mounts to adjust steering-shaft clearance and universal-joint angles. The solid billet aluminum base-and-clamp assembly uses our slot-tab positioning method for perfect alignment with the factory-welded g-Machine crossmember. Once tightened into mating grooves at the widest portion of the rack body, the deflection-free mount completely prevents the rack from shifting.

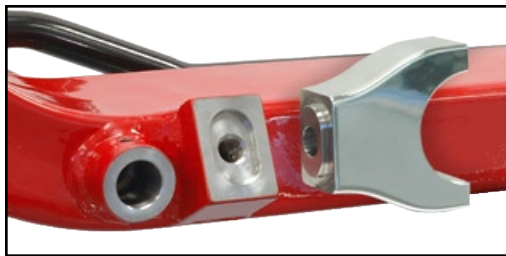
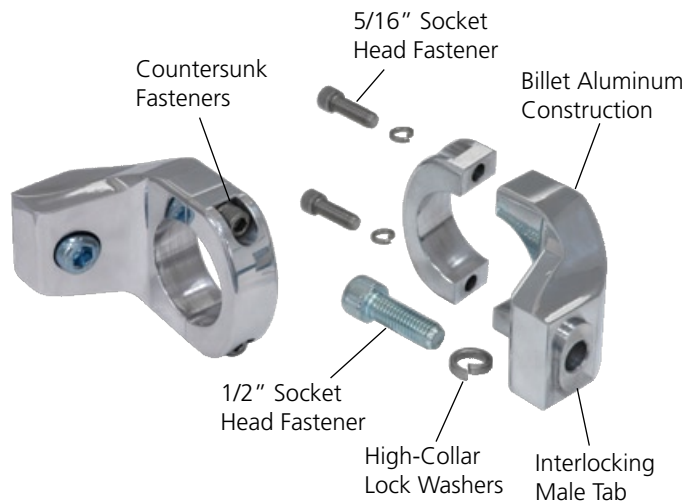

Slot-Tab Technology, Interlocking Joint



Pinion Rotated **Up**



Pinion Rotated **Down**

### Internal Components

For smooth gear engagement and extended service life, helical-cut rack-and-pinion gears are guided by a combination of low-friction, polymer bushings and roller bearings. A gear-lash mechanism enables precise and predictable "zero-play" steering with no need for future adjustment. Tie-rods are screwed directly into the rack gear and locked using crush tabs to prevent loosening. During final assembly all internal components are thoroughly lubricated and durable rubber boots attached to completely seal the rack and prevent contaminants from entering. Connecting the rack and pinion requires a 16.8-mm DD universal joint, 9/16"-18 female-thread tie-rods or bumpsteer adjusting sleeves, and -6 AN high-pressure hose ends. Kits are available with black-powder-coat-finished rack and anodized-satin-finished mounts or chrome-plated rack with polished mounts.

## Common Specifications

Feature	Specification/Dimension
Rack Travel	3 turns lock to lock, 1.8" per turn, 5.375" total travel
Inner-Tie-Rod Thread	9/16-18 RH Male
Inner-Tie-Rod Length <sup>1</sup>	10.135"
Tie-Rod Assembly Length <sup>2</sup>	13.283"
Input Shaft	16.8-mm DD
Hydraulic Fittings	-6 AN (pressure and return)
Recommended Pump Flow Rate	1.0 - 1.5 gpm (3.8 - 5.7 lpm)
<b>Notes:</b>	
1	Measured from tie-rod pivot center to end of threaded shaft.
2	Measured from center of inner- and outer-tie-rod pivots.

## Specific Rack Dimensions

Callout	Feature	6140-215-X	6140-245-X
A	Inner Pivot Width	21.50"	24.50"
B	Overall Rack Width (no outer tie-rods)	41.75"	44.75"
C	Overall Rack Width (with outer tie-rods)	48.00"	51.00"

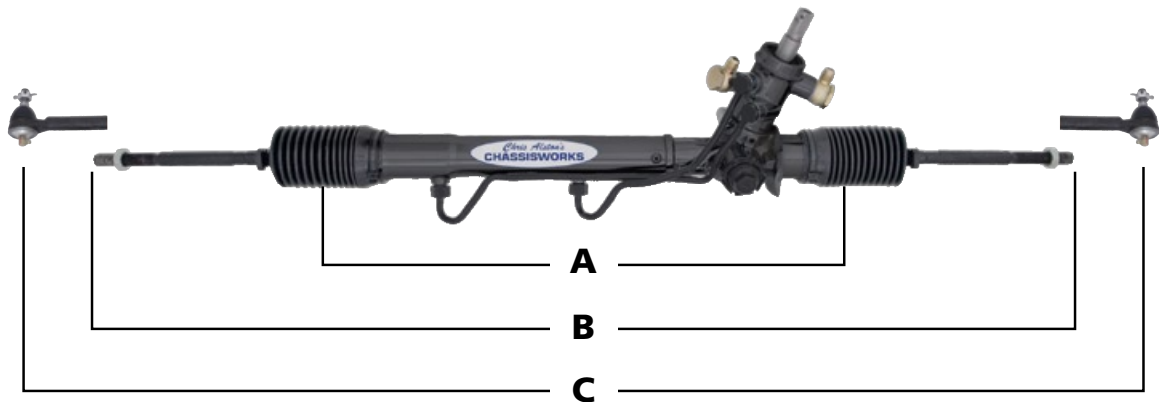

## g-Machine Crossmember Dimensions

Callout	Feature	6140-215-X	6140-245-X
D	g-Machine Crossmember Width	30"	33"
E	Hub-to-Hub Width	57"	60"

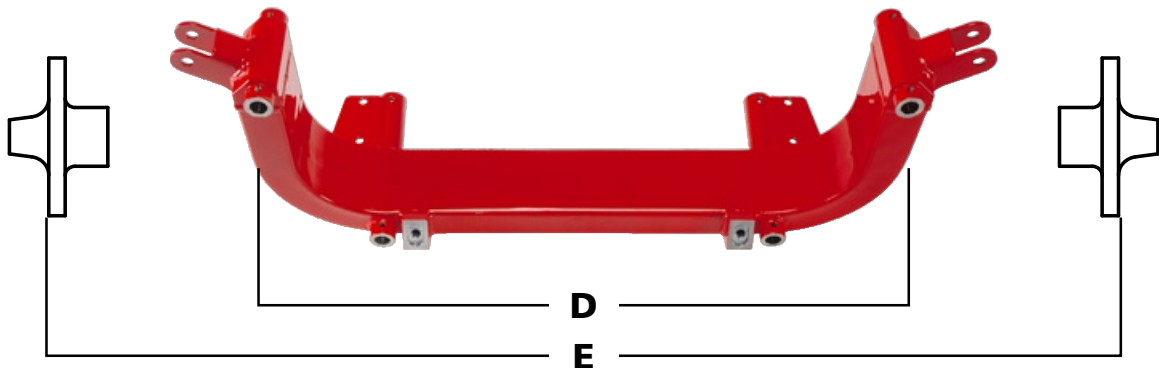

## Left-Hand-Drive Rack and Pinions



## Right-Hand-Drive Rack and Pinions



Part Number	Description	Price
6140-215-1	g-Machine Power Rack, 21.5" Left-Hand-Drive, Black Finish	\$675 <sup>00</sup>
6140-215-2	g-Machine Power Rack, 21.5" Left-Hand-Drive, Chrome Finish	799 <sup>00</sup>
6140-245-1	g-Machine Power Rack, 24.5" Left-Hand-Drive, Black Finish	675 <sup>00</sup>
6140-245-2	g-Machine Power Rack, 24.5" Left-Hand-Drive, Chrome Finish	799 <sup>00</sup>
6140-215-1RIGHT	g-Machine Power Rack, 21.5" Right-Hand-Drive, Black Finish	700 <sup>00</sup>
6140-215-2RIGHT	g-Machine Power Rack, 21.5" Right-Hand-Drive, Chrome Finish	825 <sup>00</sup>
6140-245-1RIGHT	g-Machine Power Rack, 24.5" Right-Hand-Drive, Black Finish	700 <sup>00</sup>
6140-245-2RIGHT	g-Machine Power Rack, 24.5" Right-Hand-Drive, Chrome Finish	825 <sup>00</sup>
6139-215-1	Billet Clamp Set for 21.5" Rack, Satin Finish	139 <sup>00</sup>
6139-215-2	Billet Clamp Set for 21.5" Rack, Polished Finish	169 <sup>00</sup>
6139-245-1	Billet Clamp Set for 24.5" Rack, Satin Finish	159 <sup>00</sup>
6139-245-2	Billet Clamp Set for 24.5" Rack, Polished Finish	189 <sup>00</sup>

All prices subject to change. Current pricing available at [www.cachassisworks.com](http://www.cachassisworks.com).



Chris Alston's Chassisworks, Inc.  
8661 Younger Creek Drive  
Sacramento, CA 95828

Order: 800-722-2269  
Tech: 916-388-0288  
Fax: 916-388-0295

sales@cachassisworks.com  
[www.cachassisworks.com](http://www.cachassisworks.com)