

# Chassisworks '64-72 A-Body g-Bar Rear Suspension

## Poly-Bushing Control Arms

**Works  
with your  
factory  
10- or  
12-bolt  
housing!**

- Replacement poly housing bushings

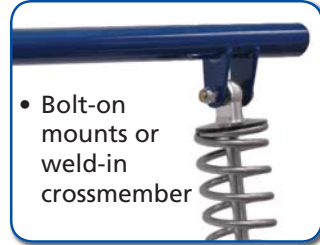

- Bolt-on mounts or weld-in crossmember

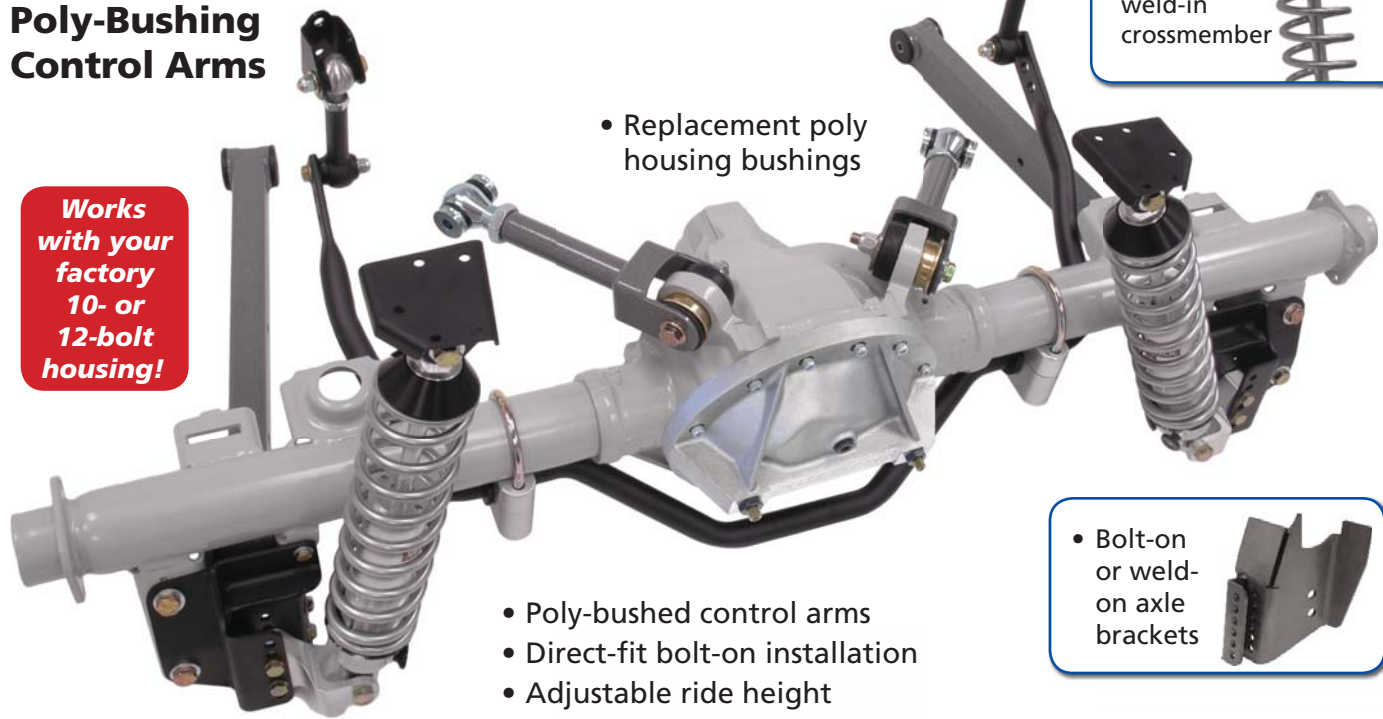

- Poly-bushed control arms
- Direct-fit bolt-on installation
- Adjustable ride height



- Bolt-on or weld-on axle brackets

## Anti-Roll Bars



- Tubular, housing-mounted, adjustable rate, with billet axle clamps
- Solid, control-arm-mounted, fixed rate

## Shocks and Springs

- Coil-over shocks with selection of spring rate
- Air-spring shocks with integrated air-sleeve
- Single- or double-adjustable valving



**Billet-aluminum shock construction!**

## FAB9™ Housing

- Mild steel or 4130
- Stock or narrowed width



## Control Arms



- Adjustable-length, tubular-steel, upper arms

- Tubular-steel or billet-aluminum lower arms

# Chassisworks '64-72 A-Body g-Link Rear Suspension

## Pivot-Ball Control Arms

**Works  
with your  
factory  
10- or  
12-bolt  
housing!**

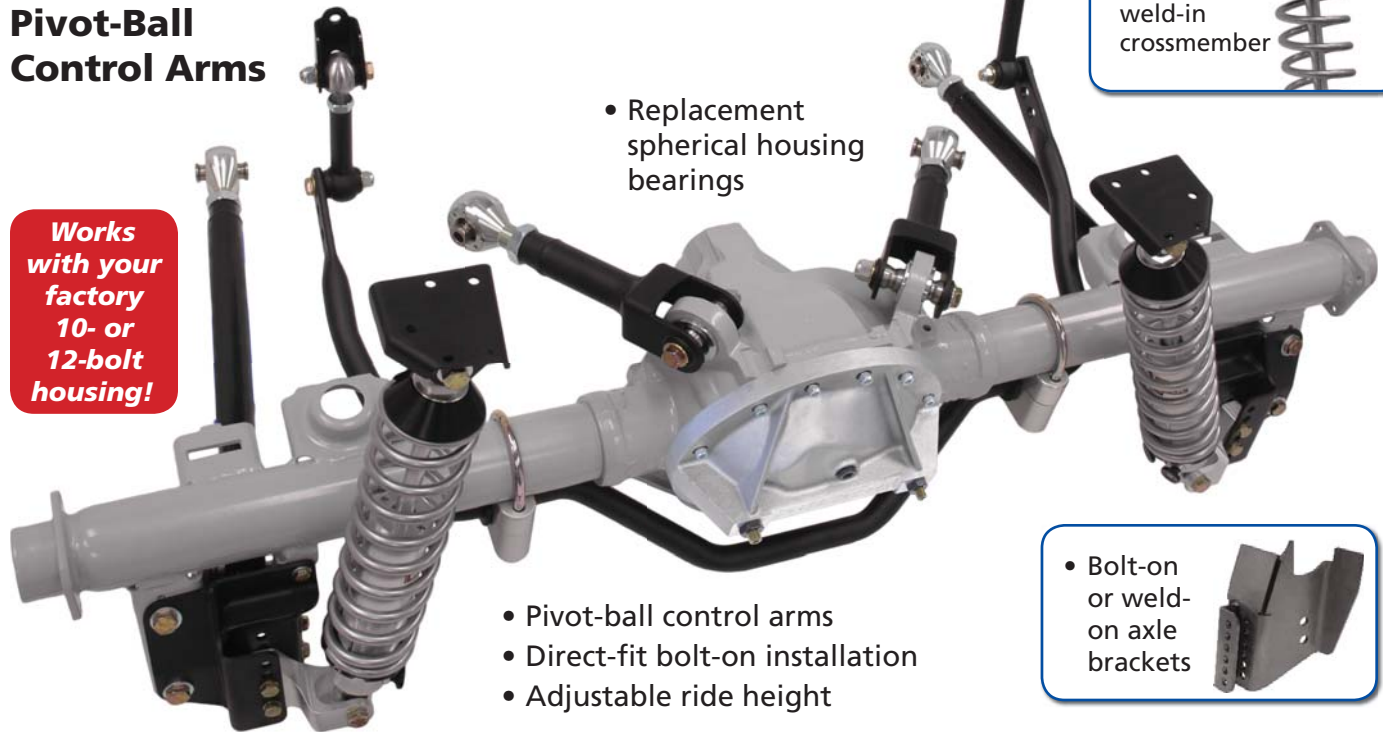

- Replacement spherical housing bearings

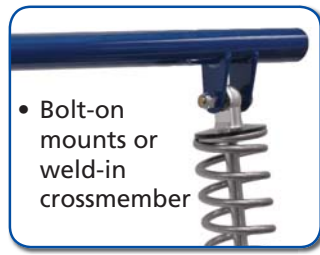

- Bolt-on mounts or weld-in crossmember

- Pivot-ball control arms
- Direct-fit bolt-on installation
- Adjustable ride height

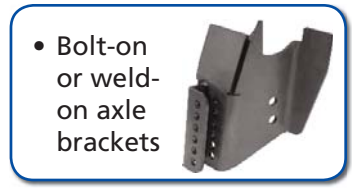

- Bolt-on or weld-on axle brackets

## Anti-Roll Bar

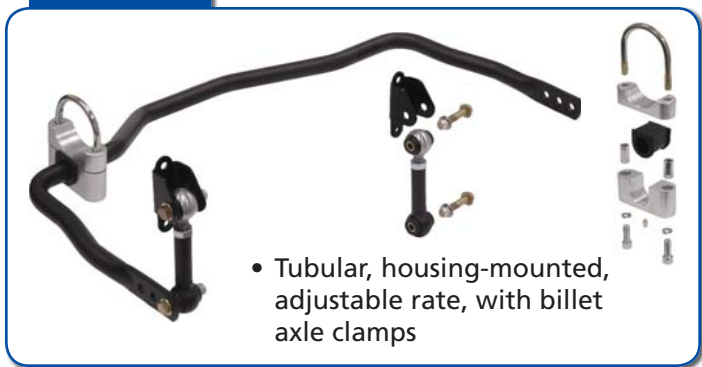

- Tubular, housing-mounted, adjustable rate, with billet axle clamps

## Shocks and Springs

- Coil-over shocks with selection of spring rate
- Air-spring shocks with integrated air-sleeve
- Single- or double-adjustable valving

**Billet-aluminum shock construction!**



## FAB9™ Housing

- Mild steel or 4130
- Stock or narrowed width



## Control Arms



- Pivot-ball, adjustable-length, tubular-steel, upper arms

- Tubular-steel or billet-aluminum lower arms

# Chassisworks '64-72 A-Body Power-Link Rear Suspension

Works with your factory 10- or 12-bolt housing!

## Spherical-Bearing Control Arms

- Offset spacers
- Billet tube adapters



- Reinforced holes
- Gusseted clevis



- Spherical housing bearings



## Shocks and Springs

- Coil-over shocks with selection of spring rate
- Single- or double-adjustable valving

**Billet-aluminum shock construction!**



## Shock Mount Options

- Accommodates custom large tire and wheel builds
- Available with 48" upper shock mount crossmember kit
- Weld-on mild-steel or 4130 axle brackets with billet shock mounts



## FAB9™ and Anti-Roll Bar Options

- FAB9™ housing - mild steel or 4130
- Folded back brace - mild steel or 4130
- Sealed or drag-style housing ends
- Stock or narrowed width



- Includes weld-on chassis brackets

- Splined billet-aluminum arms
- Anti-roll bar also sold for installation with existing housing

*NOTE: All suspension systems listed also available with OEM-style shock and spring configuration. Call or visit for info.*

### **g-Bar Coil-Over Rear Suspensions (poly-bushing control arms)**

5827-A10	'64-67 GM A-Body g-Bar Coil-Over Rear Suspension	\$1198-up
5827-A20	'68-72 GM A-Body g-Bar Coil-Over Rear Suspension	1198-up
INCLUDES	Tubular-steel upper and boxed-steel lower control arms, QuickSet-1 single-adjustable VariShock coil-overs, adjustable-height billet lower shock mount, and choice of bolt-on axle and chassis brackets or weld-on mild-steel axle brackets and upper shock crossmember	
OPTIONS	Billet lower control arms (System P/N: 5844-A10 and 5844-A20)	add 100.00
	Weld-on 4130 axle brackets	add 100.00
	QuickSet-2 double-adjustable VariShock coil-overs	add 200.00
	Spring rates over 300 lb/in	add 20.00
	Solid, fixed-rate anti-roll bar (chassis mounted)	add 139.00
	Tubular, adjustable-rate anti-roll bar (housing mounted)	add 450.00

### **g-Link Coil-Over Rear Suspensions (pivot-ball control arms)**

5828-A10	'64-67 GM A-Body g-Link Coil-Over Rear Suspension	\$1498-up
5828-A20	'68-72 GM A-Body g-Link Coil-Over Rear Suspension	1498-up
INCLUDES	Tubular-steel upper and lower control arms, QuickSet-1 single-adjustable VariShock coil-overs with springs, adjustable-height billet lower shock mount, and choice of bolt-on axle and chassis brackets or weld-on mild-steel axle brackets and upper shock crossmember	
OPTIONS	Billet lower control arms	add 100.00
	Double-adjustable upper control arms	add 40.00
	Weld-on 4130 axle brackets	add 100.00
	QuickSet-2 double-adjustable VariShock coil-overs	add 200.00
	Spring rates over 300 lb/in	add 20.00
	VariShock spanner wrench	add 20.00
	Tubular, adjustable-rate anti-roll bar (housing mounted)	add 450.00
	Rearend reinforcement girdle cover (10- or 12-bolt)	add 155.00

### **Power-Link Coil-Over Rear Suspensions (spherical-bearing control arms)**

5829-A10	'64-67 GM A-Body Power-Link Coil-Over Rear Suspension	\$1579-up
5829-A20	'68-72 GM A-Body Power-Link Coil-Over Rear Suspension	1579-up
INCLUDES	Tubular-4130 upper and lower control arms, QuickSet-1 single-adjustable VariShock coil-overs with springs, adjustable-height billet lower shock mount, and choice of bolt-on axle and chassis brackets or weld-on mild-steel axle brackets and upper shock crossmember	
OPTIONS	Weld-on 4130 axle brackets	add 100.00
	QuickSet-2 double-adjustable VariShock coil-overs	add 200.00
	Spring rates over 300 lb/in	add 20.00
	Drag-race, splined-arm anti-roll bar (housing mounted)	add 500.00
	Rearend reinforcement girdle cover (10- or 12-bolt)	add 155.00

### **Housing and Hardware Options**

84A10-XXX	FAB9™ '64-72 GM A-Body rearend housing, factory-welded	\$769-up
5834-A10-HU	Axle-housing poly bushings, '64 GM A-body	25.00
5834-A11-HU	Axle-housing poly bushings, '65-87 GM A- and G-body	29.00
5834-A11-HB	Axle-housing spherical-bearing, '64-87 GM A- and G-body	119.00

Prices subject to change.