

5. After the bearing is packed, drop it in the bearing race. The inner wheel bearing seal is then positioned on the hub.
6. Place the hub on a wood surface before installing the seal. Using a hammer and seal installer, drive the seal into the hub making sure it's fully seated.
7. With the inner bearing and seal in place, slide the hub and rotor assembly onto the correct spindle (remember, the slotted rotors are directional).
8. Pack the outer wheel bearing as you did the inner one. Slide the bearing into the race.
9. Slide the washer over the spindle shaft and install the castle nut.
10. To fully seat the bearings, tighten the castle nut to 12 ft. lbs. while turning the rotor assembly forward by hand. This will remove any grease that could cause excessive wheel bearing play. Back off the castle nut to the "just loose" position and then hand tighten. There will be .001 to .005 inches of endplay when the wheel bearings are properly adjusted.
11. After the wheel bearings are tight, insert the cotter pin through the castle nut and the hole in the end of the spindle shaft. Do not tighten the castle nut when aligning the cotter pin, only loosen it. Fold the cotter pin legs to secure the castle nut.
12. Apply anti-seize to the threads of the screw-on dust cap. Screw the dust cap onto the hub. It only needs to be hand tightened, the o-ring inside will keep it from coming loose.
13. For kit nos. 3069, 3070, or 3071, install the Wilwood brake calipers and pads. Start by inserting the brake pads into the caliper, one on each side of the rotor slot with the metal backing toward the pistons.
14. Slide the caliper with the pads installed over the rotor and the caliper mounting pads on the spindle. Use the 3/8-16 x 1 3/8 socket head Allens, lockwashers, and flat washers provided in your brake kit to mount the calipers. The lockwasher goes against the head of the fastener.
15. Use an Allen wrench to tighten the mounting bolts. Rotate the rotor assembly slowly to check for any clearance problems between the rotor and the caliper. Make sure the rotor does not drag on the brake pads. The caliper can be shimmed where it attaches to the caliper bracket to adjust the pad clearance in relation to the rotor.
16. Finally, bolt your wheel and tire on the hub and check again to be sure there is at least 1/4" clearance between the caliper and the wheel. There are differences in wheel manufacturer's tolerances. Make sure your wheel turns freely and does not rub on the caliper.

Revision Date: February 21, 2003



**8337**  
**HEAVY DUTY BRAKES FOR CHASSISWORKS**  
**DRAG RACE FABRICATED SPINDLES**

<u>ITEM</u>	<u>QTY</u>	<u>PART NO.</u>	<u>DESCRIPTION</u>
1	2	1306-2	Cap for front hub
2	2	1317-2	Heavy duty polished hub
3	2	3352	Bearing cup 2.3280 OD
4	2	3353	Bearing cone 1.3775 ID
5	2	3354	Bearing cup 1.7810 OD
6	2	3355	Bearing cone .8656 ID
7	2	3537	O-ring hub cap
8	2	3631	Grease seal 2.5 x 1.94 x .25
9	10	3229	Aircraft washer 1/2
10	4	3242	High collar lockwasher 3/8
11	4	3253	Stainless 3/8 washer
12	10	3417	Bolt 12 point 1/2-20 x 2 1/4
13	4	3441	Socket head allen 3/8-16 x 1 3/8
14	1	1708	Rotor drivers side
15	1	1709	Rotor passenger side
16	10	3229	Aircraft washer 1/2 x .062
17	10	3447	Wheel stud 12 point 1/2-20 x 3
18			Optional Calipers & Pads

1. The 11 3/4 x .81 inch slotted rotors are directional. The passenger side rotor is identified by the "P" machined on the inside. There is a "D" on the driver side rotor. If you have the solid rotors the driver and passenger sides are the same. These brakes require at least a 15" diameter wheel; however, even some 15" wheels may not clear. Verify you have at least 1/4" of wheel clearance from all brake components.
2. The billet aluminum hubs have threaded-stud-mounting holes for both 4 1/2 and 4 3/4 inch bolt circles. Choose the bolt circle that matches your wheels and chase the threads with a 1/2-20 tap. After chasing the threads, it is a good idea to blow them out with an air hose making sure no debris remains in the holes.
3. Set the rotor on the backside of the billet hub. Line up the bolt circles on the hub with those on the rotor. Slide a 1/2 aircraft washer over the 1/2-20 x 3" 12 point wheel stud, add a drop of Loctite™ to the threads, up near the head and insert the studs through the proper series of holes. Insert all the wheel studs and tighten them from the backside of the assembly. The 2 1/4' studs can be used if you have thin wheels.
4. The bearing races are pressed in the billet hub from the factory. You must pack the wheel bearing before installing it. Use a wheel-bearing packer to do this. If you do not have one available, hand packing the bearing is okay. If you are unsure how to pack the bearing, refer to an auto repair manual for assistance.

THIS DRAWING CONTAINS PROPRIETARY INFORMATION OF CHRIS ALSTON'S CHASSISWORKS, INC. AND SHALL NOT BE REPRODUCED, TRANSFERRED TO OTHER DOCUMENTS, DISCLOSED TO OTHERS, USED FOR MANUFACTURING, OR FOR ANY OTHER PURPOSE, IN WHOLE OR IN PART WITHOUT PRIOR WRITTEN PERMISSION OF CHRIS ALSTON'S CHASSISWORKS, INC.

PART NO. **918337** SHEET **1** REV. **0**

REVISIONS				
ZONE	REV	DESCRIPTION	DATE	APPROVED

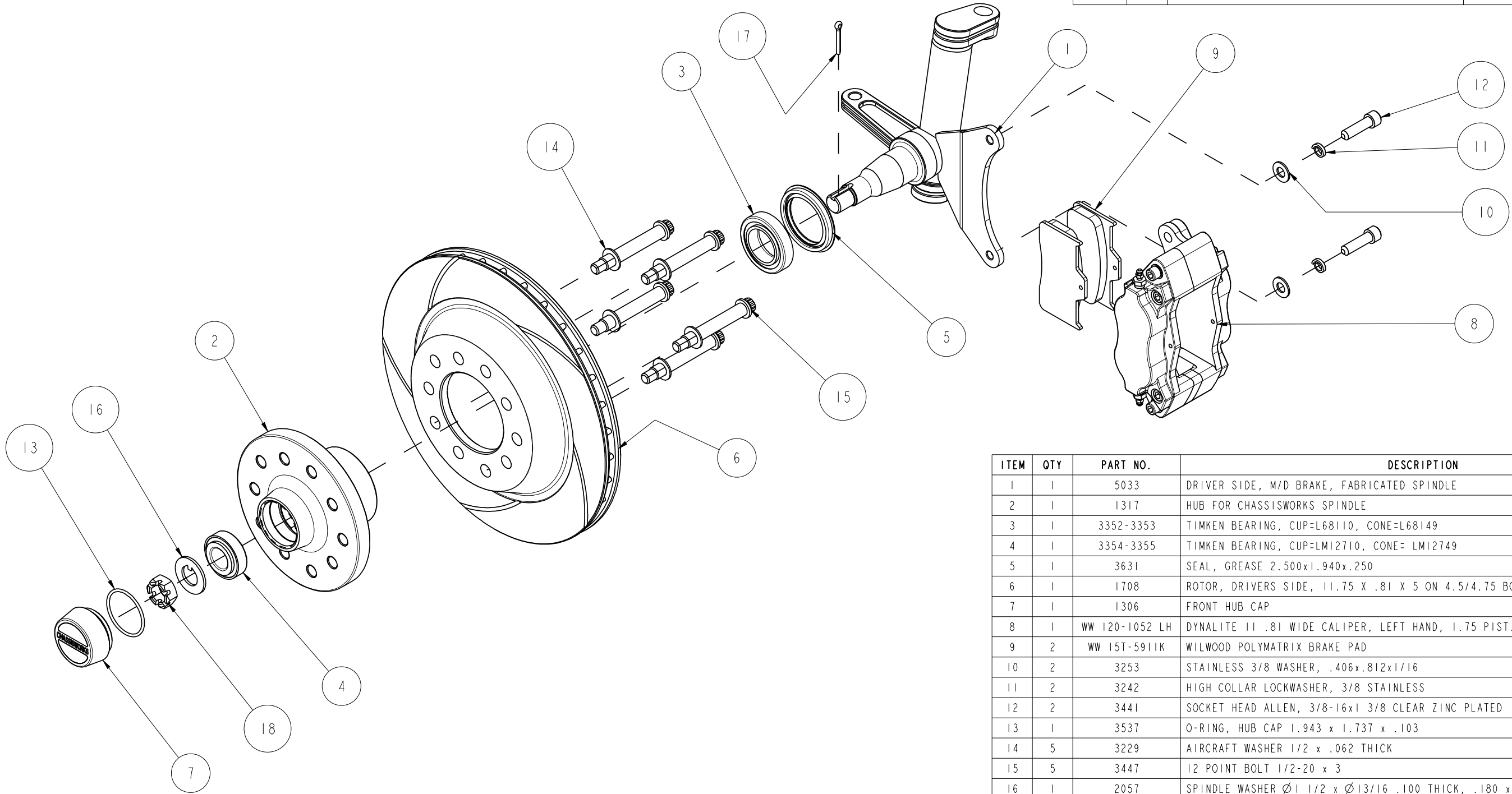

ITEM	QTY	PART NO.	DESCRIPTION
1	1	5033	DRIVER SIDE, M/D BRAKE, FABRICATED SPINDLE
2	1	1317	HUB FOR CHASSISWORKS SPINDLE
3	1	3352-3353	TIMKEN BEARING, CUP=L68110, CONE=L68149
4	1	3354-3355	TIMKEN BEARING, CUP=LM12710, CONE= LM12749
5	1	3631	SEAL, GREASE 2.500x1.940x.250
6	1	1708	ROTOR, DRIVERS SIDE, 11.75 X .81 X 5 ON 4.5/4.75 BOLT CIRCLE
7	1	1306	FRONT HUB CAP
8	1	WW 120-1052 LH	DYNALITE II .81 WIDE CALIPER, LEFT HAND, 1.75 PIST. DIA.
9	2	WW 15T-5911K	WILWOOD POLYMATRIX BRAKE PAD
10	2	3253	STAINLESS 3/8 WASHER, .406x.812x1/16
11	2	3242	HIGH COLLAR LOCKWASHER, 3/8 STAINLESS
12	2	3441	SOCKET HEAD ALLEN, 3/8-16x1 3/8 CLEAR ZINC PLATED
13	1	3537	O-RING, HUB CAP 1.943 x 1.737 x .103
14	5	3229	AIRCRAFT WASHER 1/2 x .062 THICK
15	5	3447	12 POINT BOLT 1/2-20 x 3
16	1	2057	SPINDLE WASHER Ø1 1/2 x Ø13/16 .100 THICK, .180 x .110 KEY TANG
17	1	3617	COTTER PIN, 5/32x1
18	1	3630	SPINDLE NUT, 3/4-20 CASTLE STYLE

UNLESS OTHERWISE SPECIFIED DIMENSIONS ARE IN INCHES TOLERANCES FRACTIONS    ANGLES    DECIMAL ±1/16        ±0.5°        ±0.1 ±0.05        ±0.01 ±0.005      ±0.005 ±0.0010	APPROVALS DRAWN BY: K. DAVIS CHECKED BY: S. REIGER DWG RELEASE LEVEL: Released	DATE 01/21/03 02/04/03	DESCRIPTION <b>H/D FAB DRAG SPINDLE BARKE,          4 PISTON CALIPER/11.75 x .81 VENTED ROTOR</b>  Chris Alston's CHASSISWORKS INC. 8661 YOUNGER CREEK DRIVE SACRAMENTO, CA 95828 (916) 388-0288 FAX 388-0295
	FINISH NONE MATERIAL ASSEMBLY	SIZE B	
SCALE: 1:4		DWG: 918337 REV: 0	SHEET 1 OF 1