

Avenger X-Style Track Locator



The X-style track locator is the ultimate lateral-locating device for high-horsepower OUTLAW cars using our Avenger scalloped 4-link.

The "X" configuration creates four triangles—the strongest geometrical space—positively locating the rearend housing in the car and eliminating the flex that occurs when a single-diagonal track locator is heavily loaded. Our exclusive swivel clevis provides a central connection point while still allowing the longest link to be rotated for adjustment. Links are constructed from 1 x .083" -wall chrome-moly tubing with CNC-machined threaded tube adapters at each end. Links are adjustable in length to precisely center the rearend housing and use heavy-

duty 5/8" -shank, Teflon®-lined, 4130-body rod ends secured by Grade 8 12-point flanged-head bolts. The X-style track-locator assembly is mounted using four billet aluminum clevises with a locating boss that prevents the clevis from rotating when in use. Clevises are secured using countersunk 12-point flanged-head bolts to increase strength and reduce their overall height. Kits are shipped unassembled to enable correct fitment to your specific application and include link tubes, swivel clevis, tube adapters, rod ends, billet mounts, and mounting hardware.

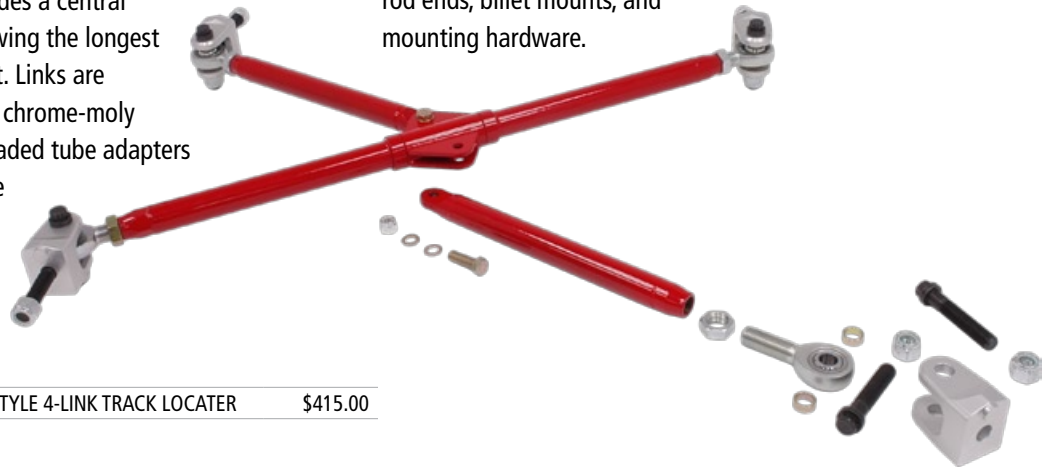

6261 AVENGER X-STYLE 4-LINK TRACK LOCATER \$415.00

Avenger Anti-Roll Bar

Chassisworks was the first chassis manufacturer to offer drag-race rear-anti-roll-bar kits. Even after numerous improvements throughout the last 20 years we have brought substantial innovation to an already proven product. Our Avenger splined anti-roll bar was designed specifically for high-horsepower OUTLAW and Pro-Mod race cars to consistently produce quicker 60-foot times by equalizing traction and preventing body roll. The anti-roll bar assembly includes a large, 1-1/4" -diameter, heat-treated, solid torsion bar with splined ends, 1-5/8 x .065" -wall 4130 mounting tube with billet bearing mounts, low-friction polymer bearings, bolt-on chassis-mounting tabs, splined billet aluminum arms, and adjustable link rods with 4130 rod ends. Our splined bolt-on billet arms eliminates free play between the antiroll bar and the arm caused by the torque created by high-horsepower OUTLAW cars. Our

exclusive bolt-in chassis mounts make removal of the antiroll bar assembly from the chassis simple. The parts are shipped unassembled for easy installation on any chassis design.



6262	AVENGER SPLINED ANTI-ROLL BAR	\$469.00
OPTIONS	WIDTH 18" TO 36" IN ONE-INCH INCREMENTS	
	AXLE-HOUSING MOUNT TABS (SET OF 4)	20.00