



Bolt-On Strut or Coil-Over Conversion 1982-1992 Camaro Installation and Tuning Guide



Description: Bolt-on strut directly replaces factory strut in 1982-1992 Camaro and can be used with coil spring in stock location. Additional components included with VAS 872DP-952 enable removal of factory positioned coil spring for conversion to 2-1/2" coil-over spring.

Note: Installation requires use of a 3/4"-bore spherical bearing caster/camber plate and cannot be used with the OEM rubber-bushing alignment plate. This product is intended for use on drag-race vehicles only and is not compatible with anti-roll bars mounted in the factory location. Read these instructions in their entirety before begin installation.

Strut Specifications

Part Number	Valving	Mounting		Total Travel	Compressed Length*	Extended Length*	Spring Length
VAS 172DP-952	Double	16mm stem, 5/8-18	1.385" wide spindle ears	6.50"	15"	21.5"	12"

*Measured from center of spherical-bearing upper mount to bottom of strut base

PART LISTS

VAS 172DP-952 – Bolt-on VariStruts 1982-1992 Camaro (struts only)

Part Number	Quantity	Description
877-D252CC0G	2	Bolt-on strut assembly for '82-92 Camaro, QuickSet 2
VAS 503-101	1	Hardware bag, strut-to-spindle bolt set, '82-92 Camaro
VAS 504-100	1	Hardware bag, 16mm strut stem

VAS 503-101 – Hardware Bag, Strut-to-Spindle Bolt Set, '82-92 Camaro

Part Number	Quantity	Description
3132-063-18B	4	Locknut 5/8-18 flanged, steel
3156-063F2.75B	4	Flanged bolt 5/8-18 x 2-3/4" hex head cap screw

VAS 504-100 – Hardware Bag, 16mm Strut Stem

Part Number	Quantity	Description
1268	2	Safety nut 5/8-18 stem strut
1329	2	Thrust stand .630" bore x 1.00" offset
3117-063-18C	2	Half locknut 5/8-18 nylon insert
899-013-203	2	Bump stop 7/8" shaft x .625" long x 2" OD

VAS 872DP-952 – Bolt-on VariStruts 1982-1992 Camaro (struts with coil-over conversion)

Part Number	Quantity	Description
899-012-201	1	Spanner wrench for VariStrut lower spring collar
VAS 172DP-952	1 (pair)	Bolt-on strut assembly for '82-92 Camaro, QuickSet 2
VAS 21-12XXX	1 (pair)	VariSpring 2-1/2" ID x 12" length (pair)
VAS 506-102	1 (pair)	16mm strut spring seats & bearing for 2-1/2 ID springs

VAS 506-102 – Spring Seat & Thrust Bearing Set

Part Number	Quantity	Description
3106-31CK0.25SP	4	Set screw 5/16-18 x 1/4", cup point, nylon patch
899-002-200	2	Lower spring seat for 2-1/2" ID springs
899-002-208	2	Upper spring seat for 2-1/2 ID springs, strut 1" extended
899-017-2431-22	4	Lower spring seat detent spring
899-018-250	4	Stainless-steel ball .250" diameter
899-053NTA-1625	2	Thrust bearing 1.000" bore x 1.562" OD x .078" thick
899-053TRA-1625	4	Thrust washer 1.000" bore x 1.562" OD x .031" thick

INSTRUCTIONS

1. Raise front of vehicle and place jack stands under the chassis so that front suspension hangs freely.
2. Remove front wheels and mark or position to install back onto the same side of the vehicle.
3. Unbolt brake caliper from spindle and secure it in an area of the inner fender well where it is out of the way. Be careful not to damage the brake line.
4. Unbolt the anti-roll-bar endlink from the A-arm.
5. Unbolt the anti-roll-bar chassis mounts and then remove the anti-roll-bar assembly from the vehicle.

6. Place a floor jack underneath the A-arm and raise slightly to take the weight off of the strut. Choose a point along the arm to place the jack so that it does not unexpectedly shift.
7. Use a spring compressor to hold the coil spring at its current state of compression. Once the A-arm is lowered, this will allow the spring to be safely removed if needed. Follow the tool manufacturer's instructions for proper use of the spring compressor.

As a safety precaution we highly recommend looping a tie-down strap or heavy wire through the coil-spring and securing it to the vehicle. Doing so prevents the spring from traveling toward you in the event it slips from its seat.

8. Using an impact gun, remove the nut at the top of the OEM strut.
9. Remove mounting hardware from the strut stem.
10. Unbolt the factory alignment plate and remove from the vehicle. Factory rivets may have to be drilled out to remove the plate.
11. Slightly lower the jack and A-arm to release any pressure on the strut.
12. Unbolt the two 5/8" bolts at the top of the spindle and remove the factory strut.
13. If converting to coil-overs or replacing the springs, the floor jack can be lowered to remove the coil spring at this time.

The spherical-bearing caster/camber plate must be installed at this time. Follow the manufacturers instructions for proper installation procedures.

Coil-Over Conversion Only: (Strut only continues at step 18)

14. Apply anti-seize to the threads on the inside of the lower spring seat and screw onto the shock body until it is 1/2" from the adjustment knobs. The spanner wrench notches in the spring seat go toward the knobs. Make sure the ball-lock set screws are backed-off enough to easily turn the spring seat.
15. Slide the urethane bump stop over the piston shaft, flat side up.
16. Place the spring over the strut followed by the upper spring seat.
17. Liberally grease and then place the trust bearing assembly onto the upper spring seat.
18. Place the thrust stand over the stem.
19. Insert the strut stem through the upper-mount spherical bearing and secure with safety nut. Hold the strut stem with a 5/16" T-handle allen wrench while tightening. Torque to 45 lb. ft.
20. Thread the 5/8-18 half locknut onto the strut stem. Torque to 40 lb. ft.
21. Tilt the spindle inward and raise the floor jack under the lower control arm until it is high enough to align the two holes in the spindle with the mounting plates on the strut. You may need to use the shim plates provided to take up any space between the spindle and the strut mounting plates.
22. Secure with two 5/8" flange bolts and locknuts. Torque to 55 lb-ft.
23. Install the brake calipers and wheels.
24. You must align the front end before testing or driving the car.

VariStrut Adjustment and Tuning Guide - QuickSet 2

This guide covers adjustment features and tuning procedures for VariStrut QuickSet 2, double-adjustable strut. The information contained has been greatly simplified and is only intended to get you started in the right direction. Suspension tuning involves multiple variables such as: spring rates, antiroll bar rates, vehicle weight distribution, tire sizes, tire pressures, suspension geometry, and track conditions. We highly recommend thoroughly researching suspension tuning and vehicle dynamics, or consulting an experienced professional.

Travel Limiters

Struts are not to be used as travel limiters. An extension travel limiter, such as a strap or cable, should be used to prevent topping out and damaging the struts. The installed compression bumper protects the strut if bottomed out during normal use. If the bumper shows signs of wear or damage it must be replaced immediately. Never operate a vehicle with a missing or damaged bumper. Vehicles that consistently land harshly from wheel stands should use a higher rate spring along with some form of suspension stop to limit compression travel without directly impacting the strut body. Any strut will be damaged if the car is dropped from a wheel stand.

Ride Height

When a strut is at ride height a certain amount of travel is available in either direction. Drag race vehicles generally require more extension (rebound) travel to help weight transfer, and because the drag strip is very flat, less compression travel is needed. The amount of extension travel available in the strut will drastically affect how the car works. The VariStrut drag race strut has 6.5" of travel. At baseline ride height, the strut and spring should collapse 4-5" from their installed heights. This results in 4-5" of available extension travel and 1.5-2.5" of compression travel.

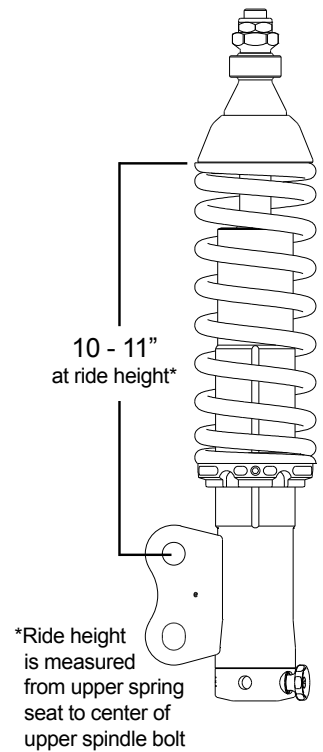

Baseline Spring Rate Selection

Spring rate affects ride quality, ride height, stored energy, weight transfer and how effectively the front suspension handles downward movement after the launch. Differences in vehicles such as specific performance application, weight reduction and chassis stiffening should be taken into consideration. Additional springs can be purchased for tuning purposes. The recommended spring rates are based on the combination of front end weight of the car and baseline strut ride height. Put scales under the front tires to determine the actual weight, and then refer to the baseline spring rate chart. The recommended rate assumes that the strut travel is at the designed ride height with the strut collapsed 4.5".

12" Spring Rate Baseline

Front Vehicle Weight (lbs)	Rate (lb/in)	Spring Travel (in)	Maximum Preload (in)	Part Number
675-775	80	8.63	2.755	VAS 21-12080
775-900	95	8.28	2.405	VAS 21-12095
900-1025	110	7.91	2.035	VAS 21-12110
1025-1175	130	8.43	2.555	VAS 21-12130
1175-1350	150	7.61	1.735	VAS 21-12150
1350-1500	175	7.60	1.725	VAS 21-12175
1500-1825	200	7.45	1.575	VAS 21-12200
1825-2200	250	7.00	1.125	VAS 21-12250
2200-2600	300	7.07	1.195	VAS 21-12300

Spring Preload

The threaded lower spring seat is used to adjust spring preload. Compressing the coil spring to any length shorter than its free height, with the strut fully extended, is considered preloading the spring. If you adjust the spring seat to change the vehicle's ground clearance, be aware that you will be adding or subtracting travel in the front strut. Usually when lighter-than-baseline spring rates are used it is necessary to add preload to achieve the correct balance of travel and ride height. If preload has been added make sure there is adequate spring travel remaining to prevent coil bind before the strut is fully collapsed. (Refer to the Spring Rate Baseline chart.)

Tuning with Spring Rate

A drag race car should run the lightest front spring rate possible, without letting the struts bottom out when making a pass. As a general guideline, lighter springs allow the car to easily transfer weight, and settle faster down track. Changing spring rate affects ride height and the rate at which weight is transferred to the rear tires. A softer rate makes the front easier to raise during acceleration. A stiffer rate makes the front harder to raise during acceleration. If you are having trouble getting the front end to rise, you can soften strut rebound valving or change to a softer spring. When using lighter rate springs preload must be added by screwing the lower spring seat upward, compressing the spring to achieve proper ride height. In general terms, the worse a car hooks the more strut extension travel it will need. If you need more extension travel, preload can be removed to lower ride height. Using this method will cause the car to have less ground clearance and reduce the amount of compression travel. If you are going to operate the strut at a ride height shorter than recommended, the upper chassis mounts must be relocated

to correct any major vehicle ride height issues. It may take some work with spring rates and upper mount relocation to get the correct combination of vehicle ride height and front suspension travel for your application.

Adjustment Features

The QuickSet 2 valve system features dual adjustment knobs that independently control bump- and rebound-damping stiffness of the strut. Dual-arrow symbols engraved into the strut body demonstrate the function of each knob. Arrows pointing toward each other designate bump (compression) adjustment; the strut collapsing. Arrows pointing away from each other represent rebound (extension) adjustment; the strut extending. Knobs are clearly etched indicating the correct direction of rotation to decrease (-), or increase (+) damping stiffness. There are 16 specific adjustment positions for each knob, with a total of 256 unique combinations possible.

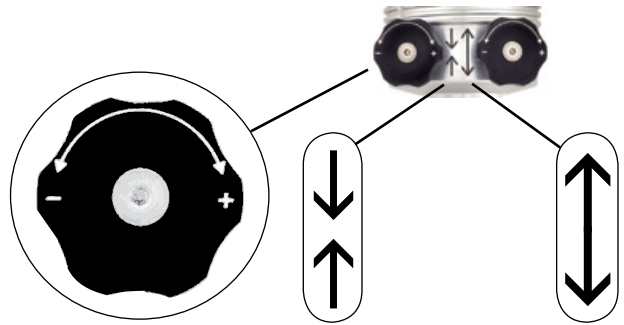

Position 1, the softest setting, is found by turning the knob in the counter-clockwise direction until the positive stop is located. Rotating the knob in the clockwise direction increases damping stiffness. Each of the 16 settings is indicated by a detent that can be felt when turning the knob, and an audible click as the knob gently locks into position. Only very light force is necessary to rotate the knob past each detent. If access to the adjustment knobs is limited, a 5/64 ball-drive Allen wrench can be used to adjust the knob. Do not force the knob beyond its intended stop, doing so will damage the valve mechanism.

Symbol	Direction	Effect
+	Clockwise	Increase Stiffness
-	Counter-Clockwise	Decrease Stiffness
↓ ↑	Bump (compression) Adjustment	
↕	Rebound (extension) Adjustment	

Note: VariStruts have a substantial range of adjustment with very little bypass or internal bleed. Due to our minimal-bleed design, struts will feel extremely stiff at some settings when operated by hand, whereas other struts with excessive bleed will move more freely. Manual comparison should not be performed. A person cannot manually operate the strut at a rate anywhere near real life conditions and any results found in this manner will be meaningless. Prior to shipping, every VariStrut is dynamometer (dyno) tested and calibrated throughout an accurate range of shaft speeds and cylinder pressures found in real-world operation.

The Truth About 16- vs. 24-Clicks

Don't be fooled by struts offering more adjustment clicks. They are actually 1/2-click adjustments. The manufacturer merely added more detents to the mechanism without increasing the range of adjustment. This practice gives more clicks, but the adjustment is so slight that your vehicle will not respond to the change. A 16-position VariStrut actually has a broader range of adjustable force with the added benefit of a more manageable number of adjustments to try.

Tuning Procedures - QuickSet 2

VariStrut's broad range of adjustment is suitable for the unique vehicle dynamic requirements of drag racing. A properly tuned drag race suspension effectively controls weight transfer and maintains traction throughout launch and each gear shift. Before proceeding verify that all suspension components, such as control arms, balljoints, and bushings are in acceptable condition and that tire pressures are correctly set.

Tuning for Drag Racing - QuickSet 2

Required settings for drag racing applications vary greatly depending upon, vehicle weight, weight distribution, suspension geometry and travel, horsepower, and available traction. A properly tuned drag race suspension enables the vehicle to launch straight while transferring weight to the rear tires in an efficient, controlled manner. Extensive testing and adjustment is critically important when operating your vehicle at or near its performance limits. Testing must be done in a safe and controlled environment, such as a dedicated motorsports facility. It is generally better to tune struts and shocks according to improvements in ET's (Elapsed Times) rather than for specific occurrences such as the amount of wheel-stand. Due to differences in weight distribution, wheel base, tire size, and horsepower, not all vehicles leave the starting line in the same manner once their suspension has been optimized. Watch your ET's and if your times start to get slower return to the prior adjustment. Once you have completed the following procedures, only fine adjustments may be needed to tune for specific track conditions.

Prior to Testing

Make certain that wheelie bars are raised as high as possible while maintaining control and eliminating their influence as much as possible on damper settings. Begin with struts adjusted to the number 3 position for bump and rebound.

Initial Testing

First verify that the vehicle tracks straight before aggressively launching from the line. Begin with light acceleration and low speeds. If the vehicle tracks and drives acceptably at this level, make incremental increases in acceleration and top speed until the vehicle is safe at higher speed. Vehicles not tracking straight at speed should verify all chassis settings including but not limited to alignment, bump steer, tire pressures, etc. Once the vehicle drives in a safe manner at speed, move on to test launching.

Test launches should consist of only the initial launch with no subsequent gear changes. Begin with low rpm launches and gradually increase rpm and severity if the car launches acceptably. At this time we are only determining that the car launches in a controlled manner to avoid damaging components or the vehicle. The vehicle should leave in a straight line without extreme wheel standing or harsh bounces. Sudden, uncontrollable front end lift should be corrected by making suspension instant center adjustments, if possible. More gradual front end lift can be corrected by adjusting the strut valving. If the car gradually wheel stands or bounces violently, adjust front suspension first, then rear. If there is rear tire shake, wheel hop or excessive body separation, adjust rear suspension first, then front. If your car is launching severely to the right or left, first check that the rear end is centered and there is no preload adjusted into the rear suspension. If the car still launches severely to the right or left, you will have to add preload to the rear suspension. If everything checks out okay and the car only minimally drives to the right or left, you can stagger the rear shock valving to correct this.

Use of a double-adjustable QuickSet 2 will allow the following procedure.

When a vehicle launches slightly toward the right, rebound (shock extension) stiffness is added to the driver side and bump (shock compression) stiffness is added to the passenger side. A vehicle launching slightly toward the left would make the opposite adjustments. It is not recommended to have more than two clicks difference side to side for either bump or rebound. Rear shock adjustments are only applicable to correcting the launch and will have little to no effect on down track performance.

After the car has been adjusted to launch straight, test launch and include the first gear change. Make any required adjustments and add the next gear change. Repeat until the car can be launched straight and driven at speed safely. The car is now ready for fine tuning to optimum results.

Front Strut Adjustment

Pay close attention to what is happening to the front end during launch. Your goal is to eliminate all jerking or bouncing movements during launch and gear shifts. Ideally the front end should rise in a controlled manner, just enough to keep the rear tires loaded, then continue the pass with smooth transitions at all times. Front end rise without any appreciable traction gain is wasted energy that should be used to propel the vehicle forward instead of up. While testing, document your ET's along with any changes made. If ET does not improve, return to previous settings.

Front Rebound (Extension) Adjustment Overview

Too light of a rebound (extension) setting allows excessive front end chassis separation and may result in the front wheels jerking violently off the ground during launch. Also, during gear change, too light a setting allows the car to bounce off its front rebound travel limiter and then bottom out in an oscillating manner. Too firm a setting will prevent the front end from rising sufficiently, limiting the amount of weight transferred to the rear tires. Adjust the rebound setting in one click increments to control the rate at which the front end rises at launch and during gear changes. While testing, document your ET's along with any changes made. If ET does not improve, return to previous settings.

Front Wheels Lose Contact with Ground	Increase Rebound Stiffness	Violent chassis separation and may result in jerking the front wheels off the ground. Increase strut rebound stiffness by one, then test again.
Rear Tires Hook Then Lose Traction	Increase Rebound Stiffness	If weight transfer occurs too quickly the rear tires may hook then lose traction as the front end begins to travel downward. Slowing the rate at which the front end rises prevents the struts from topping out too quickly and increases the duration of time that the rear tires benefit from the weight transfer. Increase strut rebound stiffness by one, then test again.
No Front End Rise	Decrease Rebound Stiffness	Too firm of a damper setting limits the amount of weight transferred to the rear tires, resulting in poor traction. Decrease strut rebound stiffness by one, then test again.

Front Bump (Compression) Adjustment Overview

After the launch or during a gear change, a firm bump setting will cause the chassis to bounce off the front tire as the chassis settles down. Too light of a bump setting allows the strut to bottom out and bounce off the stop travel bumper. Adjust bump in one click increments to control the amount and rate at which the front end settles during gear change. While testing, document your ET's along with any changes made. If ET does not improve, return to previous settings.

Front "Bottoms Out" After Launch	Increase Bump Stiffness	If front suspension settles too fast after launch or gear change it may cause the front suspension to bottom out at the end of its downward travel. If the suspension bottoms out hard enough, rear traction may be lost. Increase strut bump stiffness by one, then test again. If increasing bump stiffness cannot extend weight transfer duration long enough, a higher rate spring should be installed.
Hard Front End Bounce (After Launch or Gear Change)	Decrease Bump Stiffness	If the tires cause the front end to bounce upon landing, the struts are too stiff. The front end should settle in a single, smooth motion. Decrease strut bump stiffness by one, then test again. This can be a very subtle problem. Watch the front tire sidewall as it contacts the ground.

Rear Shock Adjustment (Double Adjustable)

Maintain traction by controlling the rate at which torque and weight is transferred to the rear tires. Ideally the rear suspension should be as firm as possible before a loss of traction occurs. Changes to the vehicle such as ride height, tire size, weight distribution, or suspension link adjustments will alter the instant center location in relation to the vehicle's center of gravity. Any shift of either the instant center or center of gravity will usually require a shock setting adjustment to optimize traction. While testing, document your ET's along with any changes made. If ET does not improve, return to previous settings.

Rear End Squats	Increase Bump Stiffness	Some vehicles will squat during launches instead of pushing the vehicle forward. To assist in planting the tires, increase shock bump stiffness by one, then test again.
Vehicle Separates from Rear End	Increase Rebound Stiffness	Some suspension geometries plant the tires so forcefully that the rear end of the vehicle rises away from the housing too rapidly. The vehicle may hook initially, then spin the tires once the shocks are topped out. Slowing the rate at which the rear end rises increases the duration of time that the rear tires benefit from the improved traction. Increase shock rebound stiffness by one, then test again.
Loss of Traction with Minimal Chassis Movement	Decrease Bump/ Rebound Stiffness	A suspension system that is too stiff can hit the tires too hard, causing a loss of traction. Softening the suspension slows the transfer of weight and reduces the initial tire shock. Minimal chassis movement makes it very difficult to visually tell if the bump or rebound needs to be decreased. We suggest adjusting bump first and watch for a gain or loss in the ET. If ET does not improve, return to previous setting, then adjust rebound instead and test again.

Completion of Testing

When all adjustments have been completed, reset your wheelie bars as low as possible without affecting your ET.

WARRANTY NOTICE:

There are NO WARRANTIES, either expressed or implied. Neither the seller nor manufacturer will be liable for any loss, damage or injury, direct or indirect, arising from the use or inability to determine the appropriate use of any products. Before any attempt at installation, all drawings and/or instruction sheets should be completely reviewed to determine the suitability of the product for its intended use. In this connection, the user assumes all responsibility and risk. We reserve the right to change specification without notice. Further, Chris Alston's Chassisworks, Inc., makes **NO GUARANTEE** in reference to any specific class legality of any component. **ALL PRODUCTS ARE INTENDED FOR RACING AND OFF-ROAD USE AND MAY NOT BE LEGALLY USED ON THE HIGHWAY.** The products offered for sale are true race-car components and, in all cases, require some fabrication skill. **NO PRODUCT OR SERVICE IS DESIGNED OR INTENDED TO PREVENT INJURY OR DEATH.**

Chris Alston's Chassisworks
8661 Younger Creek Drive
Sacramento, CA 95828
Phone: 916-388-0288
Technical Support: tech@cachassisworks.com

