

3. If you are installing our driveshaft loop (part #6021), it installs on top of the crossmember even with the front edge. Cut the loop to the correct height. The top of the loop should be 1 inch above the stock driveshaft tunnel. The driveshaft will be very high in the tunnel - you need all the room you can get. Contour the tunnel around the loop and weld it on. This will give you a good seal to the interior kit. The driveshaft loop should have the same offset as the crossmember. Make sure you have enough clearance for the driveshaft throughout its travel while trial fitting the crossmember and driveshaft loops.

4. The rear frame needs to be trimmed at each end to fit in the car. To cut the front to the correct length, measure 17 1/4" straight down from the top of the bend over the rear end and cut off the excess (see the assembly drawing). Measure from the back of the crossmember to the taillight panel. Cut the frame rails to this length and tack them in place. In cars with a rear frame crossmember that holds the bumper on, it is a good idea to attach the stock crossmember to the new subframe. Retain the stock crossmember to mount the bumper and rear of the body to. The frame rails should be centered in the car an equal distance from the car's centerline. They should be a minimum of 20" wide on the outside. Make the frame as wide as possible while leaving enough room for the tire. Make sure the rails are centered on the taillight panel and on the crossmember. They should be an equal distance from each side of the car and at the same height. The rear of the rail (the part in the trunk) should be level to the rocker panel plus or minus 2 degrees. The optional 1 5/8 round rear frame rails install at the same height as the 3x2 rear frame.

5. Install the crossmembers. The rear crossmember should be even with the bottom of the frame and approximately 1/2-inch forward of the taillight panel. Weld the shock brackets to the center crossmember at the dimension shown on the assembly drawing. Make sure they are straight to each other. Put the crossmember between the frame rails at the dimensions shown.

6. Install the chassis 4-link mount. The 4-link mount attaches to the back side of the frame and crossmember with the brackets even with the outside edge of the frame. Use a rod end to get the correct spacing between them. The brackets must be straight or the 4-link will not fit right. After you have double checked all dimensions, finish welding the frame in. The front brackets are part of the 4-link kit #6205. Also, you will need to use an adjustable lower shock mount (part #6216) with coil over shocks.

7. Install the subframe connectors (in full frame cars like '55-'57 Chevys, Chevelles, etc., the connectors are not necessary because the frame welds to the dropped crossmember). They run from the dropped crossmember forward to the stock front subframe. The floor will have to be slotted for the connectors. In most cases, the connector will be wider spaced at the front than at the dropped crossmember, where it should be the same width as the new rear frame.

8. If you are using a tire with a diameter smaller than 32", raise the adjustable shock mount on its axle bracket to raise the rear of the car.

9. If you purchased the frame clip welded the dropped crossmember and the rear frame length will be too long. Cut them to length for your application. The rear frame crossmember is tacked between the rails for shipping purposes. Knock it out and reinstall it at the correct position after you have trimmed the rear rails to length.

Revision Date: January 1, 2021

File: 917114.pdf

Chris Alston's
CHASSISWORKS, INC.

7114
INSTRUCTIONS FOR 4-LINK REAR FRAME

<u>ITEM</u>	<u>QTY</u>	<u>PART #</u>	<u>DESCRIPTION</u>
1	1 pr.	4502	Frame rail rear 4-link
2	1	4500	Crossmember dropped 3 x 2
3	2	1852	Tube 1 5/8 x .134 ERW 30"
4	2	1851	Tube 3 x 2 x .120 ERW 54"
5	4	2101	Shock bracket
6	2	2000	4-link gusset
7	1	927114	Assembly drawing

NOTE: This kit is designed to provide a rear subframe for use with coil over shocks and a 4-link. It should be used with at least an 8 point roll cage. It is a good idea to "X" the roll cage rear struts and add the 1 1/4 long rear struts (our part #7006). The frame can be installed one of two ways. The first method is to cut out the entire floor from the dropped crossmember to the tail-light panel. This will require that the floor be replaced with aluminum or steel panels. The second method is to make a 2 inch notch in the stock floor for the crossmember and rear frame rails. The only part of the floor you cut out is where the wheel wells go and a portion of the floor between the frame rails above the rear end. The floor above the rear end will have to be replaced with aluminum or steel panels.

1. Measure 24" forward from the rear axle centerline to a point on the rocker panel. Draw a line between these points on the car's floor. This is sometimes easier to do under the car because of the driveshaft tunnel. Cut the entire floor and wheel wells out of the car from your line to the rear taillight panel. Cut out the package tray and double panels against the sides of the car leaving the inner part of the rocker panel in place. In most cases, you will have to remove most of the rear window crank mechanism to make room for the new wheel wells. Usually a simple bracket welded to the body and bolted to the window will hold the windows up. When you are cutting out the stock driveshaft tunnel, leave it approximately 2" longer than the frame crossmember. This will allow for a neater installation of the aluminum.

If you elect method two, just cut a 2 inch wide slot across the car with its forward edge at 24". Leave the driveshaft tunnel intact and do not notch it as the dropped crossmember goes beneath it.

2. Install the dropped crossmember first. After you have cut the floor out and neatly trimmed all the panels, you must level the car front to rear and right to left. The door sills are a good place to put your level. When you cut the floor out, you should have left the inner part of the rocker panel in place. The rocker panel should be trimmed to allow for a good fit of the dropped crossmember. The drop in the crossmember will usually be offset from the center of the car to the passenger side about 1/2-inch. This is because most cars have an offset engine. Measure your stock rear end to determine the amount of offset. After you have determined the crossmember offset, cut it to fit between the rocker panels. If your inner rocker panel is not straight, you will have to contour the ends of the crossmember. Make sure you have a good fit to the rocker panel or it will be difficult to weld. Tack weld the crossmember in place so the forward side is 24" forward of the rear axle centerline. The bottom should be even with the bottom of the rocker panel. The stock floor should butt up against the front of the crossmember with the driveshaft tunnel overhanging the top of the crossmember. In most cases, the floor will hang below the crossmember so just push it up and tack it to the crossmember.

TOP VIEW

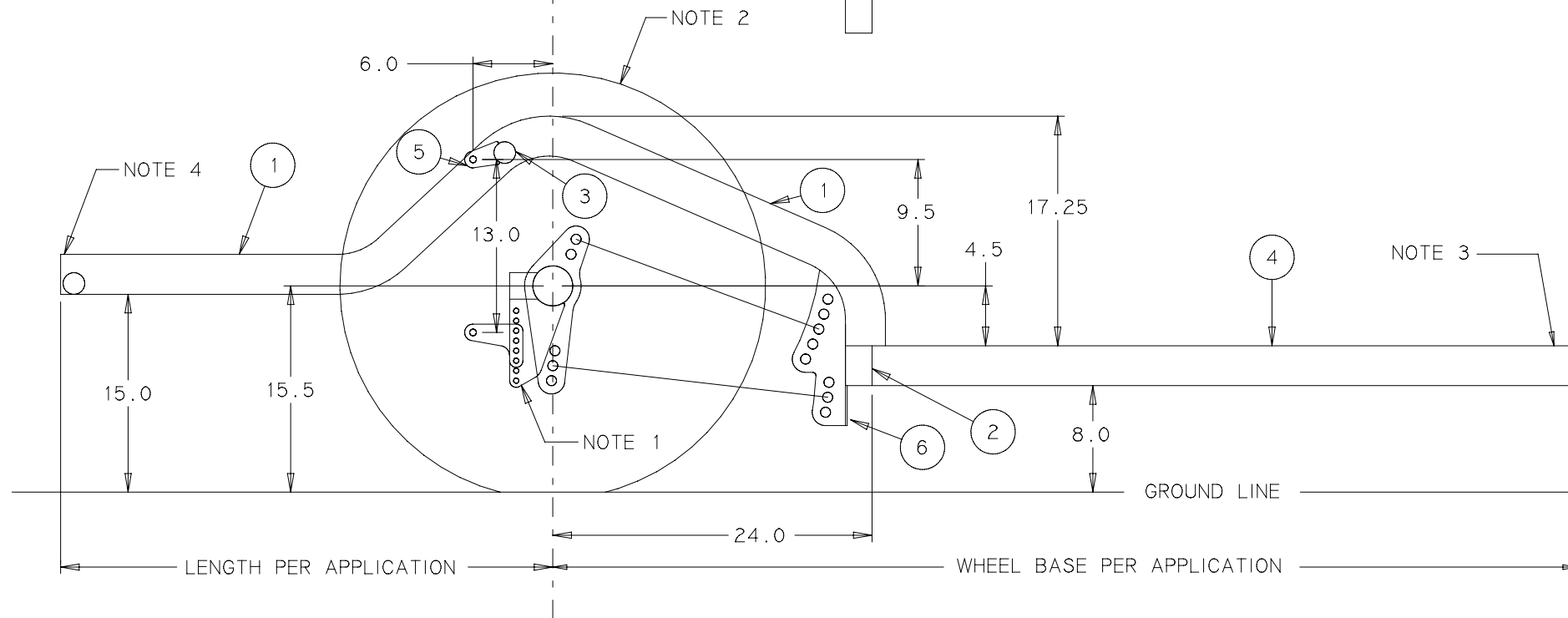
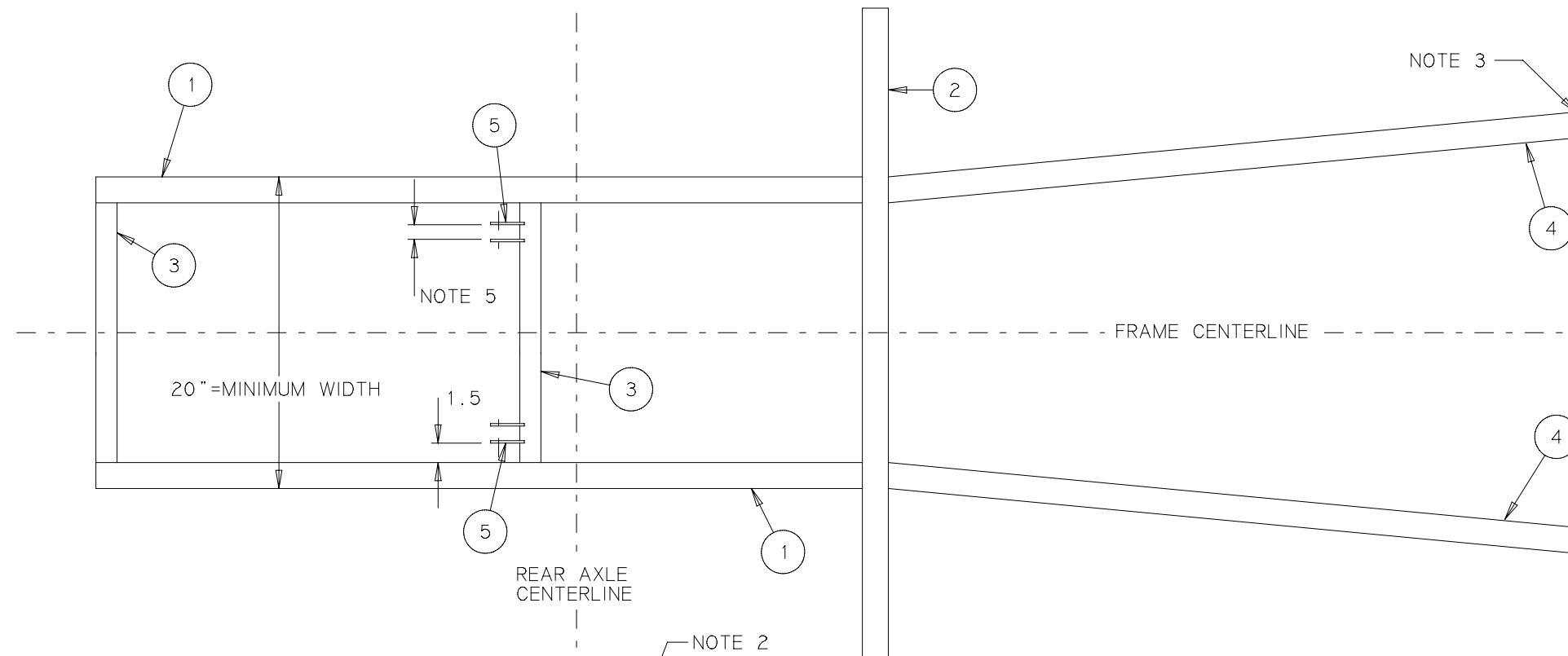

SIDE VIEW

7114 4 LINK 3x2 FRAME

CHRIS ALSTON'S CHASSISWORKS INC
8661 YOUNGER CREEK DRIVE
SACRAMENTO, CA 95828

DATE: 1/10/1992

REVISION: 3

DO NOT SCALE DRAWING

SEE THE INSTRUCTION SHEET FOR THE ITEM NUMBER DESCRIPTIONS

NOTE 1
ADJUSTABLE HEIGHT SHOCK MOUNT AND 4 LINK MUST BE PURCHASED SEPARATELY.

NOTE 2
ALL CHASSIS TO GROUND HEIGHT DIMENSIONS ARE FIGURED WITH A 32" DIAMETER TIRE.

NOTE 3
ATTACH TO STOCK FRONT FRAME OR UNIBODY SUBFRAME.

NOTE 4
ATTACH END OF FRAME TO TAIL LIGHT PANEL OR REAR VALANCE.

NOTE 5
SHOCK MOUNT BRACKET INNER WIDTH IS DIFFERENT DEPENDING ON THE SHOCK ABSORBER USED.
KONI COILOVER = 1.125"
COIL SPRING MOUNT 6225 = 1.30"