

5. Verify that your driveshaft oval has the correct offset from the vehicle's centerline to match the factory offset. Make sure you have enough clearance for the driveshaft throughout its travel while trial fitting the crossmember. Tack weld the crossmember in place so the forward side is 26 inches forward of the rear axle centerline. The bottom should be even with the bottom of the rocker panel or stock frame. The stock floor should butt-up against the front of the crossmember. In unibody vehicles only, the floor will hang below the crossmember. Push it up and tack it to the crossmember. The factory driveshaft tunnel will not be high enough to reach the top of the new driveshaft oval. Chassisworks manufactures part #6626 steel driveshaft tunnel. It should be used to replace the factory driveshaft tunnel. It can be easily welded in place.

6. The rear frame needs to be notched at the front end and shortened at the rear to fit in the car. Cut out the bottom front corner of the frame to clear the 2x4 crossmember. To cut the front to the correct length, measure 4 inches up from the bottom of the frame and 2 inches back from the front of the frame (see the assembly drawing). To determine how much to cut off the rear of the frame, measure from the front of the crossmember to the taillight panel. Cut the frame rails to this length and tack them in place. In cars with a rear frame crossmember that holds the bumper on, it is a good idea to attach the stock rear crossmember to the new subframe. Retain the stock crossmember to mount the bumper and rear of the body to. Some fabrication may be required if the height or width of the new frame and the bumper mount do not match closely. Tack the new frame rails in place. The frame rails should be centered in the car an equal distance from the car's centerline. They should be a minimum of 20" wide on the outside. Make the frame as wide as possible while leaving enough room for the tires. Make sure the rails are centered on the taillight panel and on the crossmember. They should be an equal distance from each side of the car and at the same height. Use a square to measure from the chassis centerline to the outside of each frame rail. The rear of the rail (the part in the trunk) should be level to the rocker panel plus or minus 5 degrees.

7. Install the round crossmembers. The rear crossmember should be even with the bottom of the frame and approximately 1/2 inch forward of the taillight panel. Verify that your shocks will fit between the upper shock mounts at the width shown on the assembly drawing otherwise; you will need to change their spacing. Weld the shock brackets to the center crossmember at the dimension shown on the assembly drawing. Make sure they are straight to each other. Put the crossmember between the frame rails at the dimensions shown.

8. Install the chassis 4-link mount. The 4-link mount attaches to the backside of the frame and crossmember with the brackets even with the outside edge of the frame. Use rod ends to get the correct spacing between them. When using the urethane bushed rod ends, use only the steel spacers provided to space the brackets. The brackets must be straight or the 4-link will not fit correctly. The front brackets are part of the 4-link kit. Cap the bottom of the frame and 4-link front mount with the provided bracket. Also, you will need an adjustable lower shock mount and a track locater or panhard bar. Do not final weld any part of the frame until after you have double checked all dimensions and installed the suspension. Move the suspension throughout its total travel and verify everything fits.

9. Do not forget to verify the driveshaft clearance. Finish welding the frame in only after you are sure everything fits.

10. Install the optional subframe connectors if you are installing this frame in a unibody car (in full frame cars like '55-'57 Chevys, Chevelles, etc., the connectors are not necessary because the factory frame welds to the 2x4 crossmember). The subframe connectors must run from the 2x4 crossmember forward to the stock front subframe. The floor will usually have to be slotted for the connectors. In most cases, the connector will be wider spaced at the front than at the 2x4 crossmember, where it should be the same width as the new rear frame.

11. If you are using a tire with a diameter smaller than 29 inch, raise the adjustable shock mount on its axle bracket to raise the rear of the car.

12. If you purchased the frame clip welded, the 2x4 crossmember and the rear frame length will be too long. Cut them to length for your application. The rear frame crossmember is tacked between the rails for shipping purposes. Knock it out and reinstall it at the correct position after you have trimmed the rear rails to length.

Revision Date: May 9, 2002

Chris Alston's
CHASSISWORKS, INC.

7152
INSTALLATION GUIDE FOR 2X4 REAR FRAME
FOR 4-LINK

<u>ITEM</u>	<u>QTY</u>	<u>PART #</u>	<u>DESCRIPTION</u>
<u>BANDED FRAME RAILS</u>			
1	1 pr.	4552	FRAME RAIL REAR 4-LINK 2X4
<u>BOX – 2X4 REAR FRAME KIT</u>			
2	2	4405	Box tube 2x4x30"
3	2	1858	Box tube 2x4x30"
4	2	1852	Tube 1 5/8 x .134 ERW 30"
		4516	Driveshaft loop 1x2 tube
<u>HARDWARE BOX 2X4 4-LINK REAR FRAME</u>			
5	4	3037	Suspension tab 1/2" hole
6	2	2101	Lower cap 4-link 2x4 frame
7	2	2355	Locknut 1/2-20
8	2	3200	Bolt 1/2-20x2 1/2
<u>OPTIONAL COMPONENTS</u>			
9	2	1070	Frame exhaust port 4 1/2 diameter x 2" long
10	2	4668	Subframe connectors 60" long

NOTE: Read all of the instructions and understand them before you begin. This kit is designed to provide a rear subframe for use with coilover shocks and a 4-link. It should be used with Chassisworks 4-link part numbers 6250 or 6251. It is a good idea to install at least an 8-point roll cage with this subframe. The best method to install this frame is to cut out the entire floor from the 2x4 crossmember to the taillight panel. This will require that the floor be replaced with aluminum or steel panels. This subframe can be used with unibody or full frame vehicles. The first step is to determine your new frames outside width. A Chassisworks rear end worksheet will help you do this.

1. Measure 26 inches forward from the rear axle centerline to a point on the rocker panel. Draw a line between these points on the car's floor. This is sometimes easier to do under the car because of the driveshaft tunnel. Cut the entire floor and wheel wells out of the car from your line to the rear taillight panel. Cut out the package tray and double panels against the sides of the car leaving the inner part of the rocker panel in place. In some cases, you will have to remove most of the rear window crank mechanism to make room for the new wheel wells. Usually a simple bracket welded to the inner body panel and bolted to the window will hold the windows up.

2. After you have cut the floor out and neatly trimmed all the panels you must level the car front to rear and right to left. The door sills are a good place to put your level. When you cut the floor out, you should have left the inner part of the rocker panel in place. The rocker panel should be trimmed to allow for a good fit of the crossmember. Use a string to make a chassis centerline on the floor. Find the center at the front of the car and at the rear, use duct tape to hold the string to the floor. You will use this later to align the new frame rails.

3. The driveshaft loop in the crossmember will usually be offset from the center of the car to the passenger side about 1/2 inch. This is because most cars have an offset engine. Measure your stock rear end to determine the amount of offset. After you have determined the crossmember offset, you can build the driveshaft crossmember. Cut the straight legs off of both 1x2 driveshaft loops so each one is 5 1/2 inches tall. Weld the loops together to form an oval. This will create a driveshaft oval loop that is 9 inches tall inside with a 7 inch outside width. Fit one end of each 2x4 tube to the driveshaft oval so the bottom of the oval is 1 1/2 inches below the 2x4 tube. Cut the 2x4-driveshaft loop crossmember to length so it fits between the rocker panels (or stock frame in a full frame car). If your inner rocker panel is not straight, you will have to contour the crossmember. Make sure you have a good fit to the rocker panel or it will be difficult to weld. You can also taper cut the bottom of the 2x4 crossmember where it attaches to your vehicle (see assembly drawing). This is an optional step.

4. If you purchased optional part number 1070, exhaust ports, now is the best time to install them. Position the exhaust ports in the crossmember about 2 inches inside of the frame. Make sure your exhaust will fit before you install them. A 4 1/2 inch holes saw work best to cut the holes. The center of the holes should be 2 1/4 inches down from the top of the crossmember.

THIS DRAWING CONTAINS PROPRIETARY INFORMATION OF CHRIS ALSTON'S CHASSISWORKS, INC. AND SHALL NOT BE REPRODUCED, TRANSFERRED TO OTHER DOCUMENTS, DISCLOSED TO OTHERS, USED FOR MANUFACTURING, OR FOR ANY OTHER PURPOSE, IN WHOLE OR IN PART WITHOUT PRIOR WRITTEN PERMISSION OF CHRIS ALSTON'S CHASSISWORKS, INC.

REVISIONS				
ZONE	REV	DESCRIPTION	DATE	APPROVED

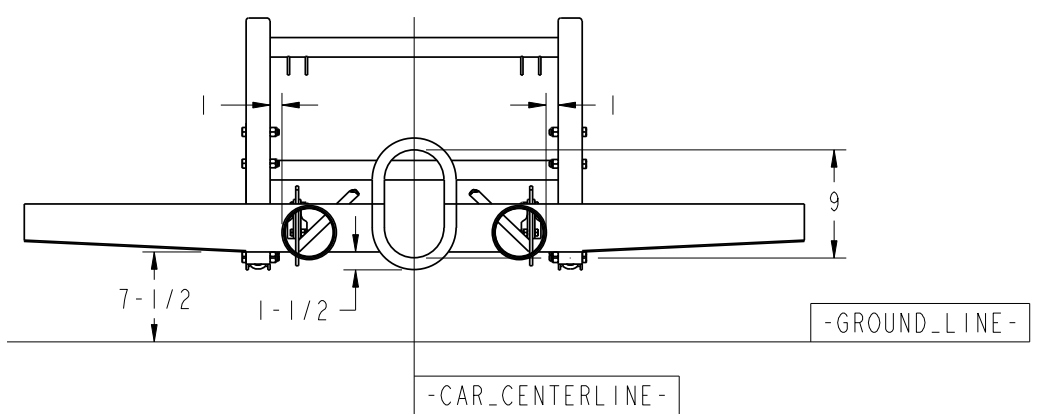
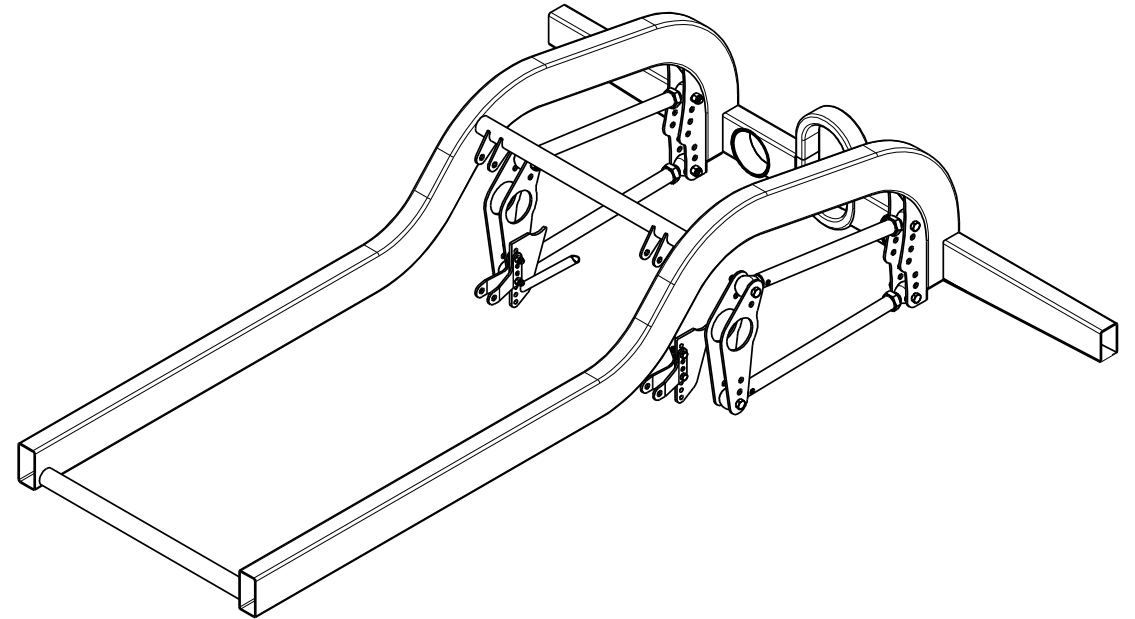
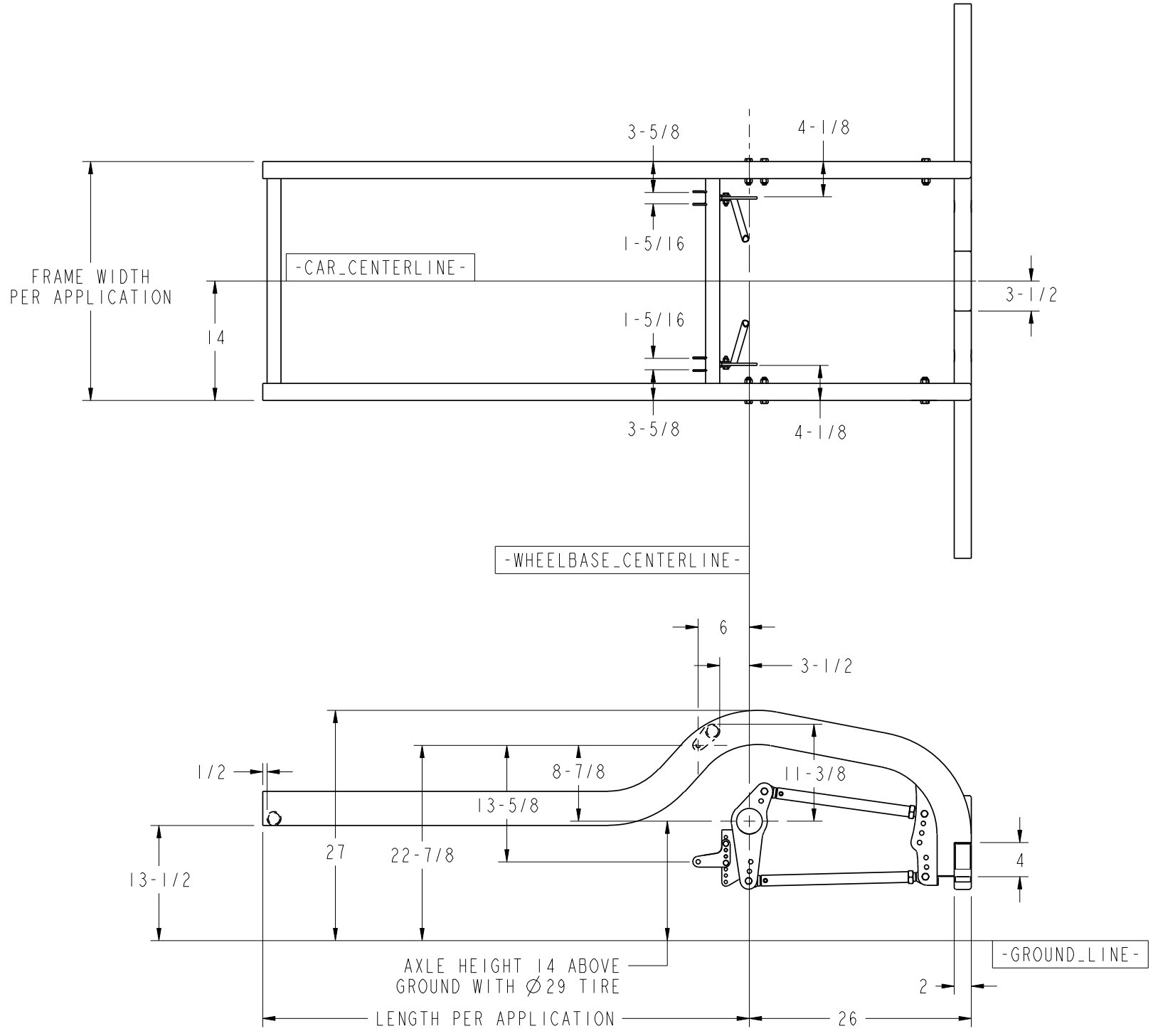

UNLESS OTHERWISE SPECIFIED		APPROVALS	DATE	DESCRIPTION	
DIMENSIONS ARE IN INCHES		DRAWN BY: M. T.	08/17/98	4 x 2 FRAME 4 LINK Chris Alston's CHASSISWORKS INC. 8661 YOUNGER CREEK DRIVE SACRAMENTO, CA 95828 (916) 388-0288 FAX 388-0295	
FRACTIONS ±1/16	TOLERANCES ANGLES ±0.5° ±0.50 ±0.500	CHECKED BY: S. RIEGER	05/28/99		
		DWG RELEASE LEVEL: Released			
FINISH NONE				SIZE B	PART NO. 7152
MATERIAL ASSEMBLY				PART REV. 0	
		SCALE: 1:16		DWG: 927152 REV: 0	
				SHEET 1 OF 1	