

READ ALL INSTRUCTIONS COMPLETELY AND THOROUGHLY UNDERSTAND THEM BEFORE DOING ANYTHING.
CALL TOTAL CONTROL PRODUCTS TECH SUPPORT (916) 388-0288 IF YOU NEED ASSISTANCE.

INSTALLATION GUIDE

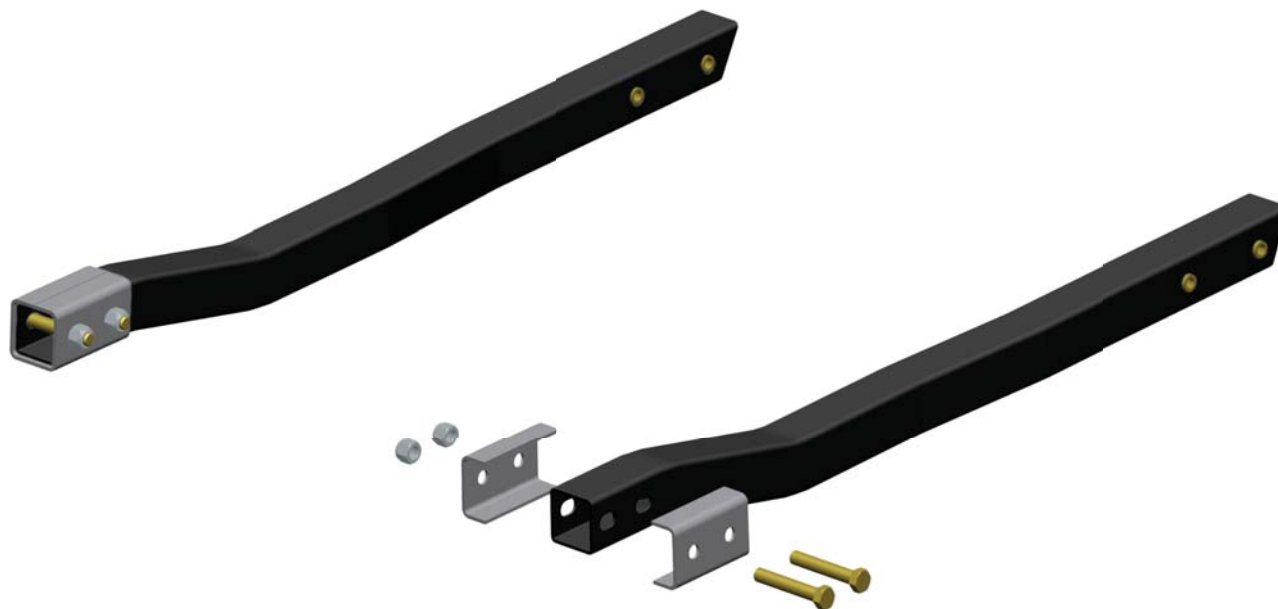

5903-F22-NF g-Connector Weld-in 1974-81 Camaro/Firebird with Chassisworks New Rear Frame



Description: g-Connector weld-in for cars with Chassisworks new rear frame and Chassisworks or OEM front subframe. OEM subframe requires weld-on adapters.

Applications: Camaro '74-81 and Firebird '74-81

ITEM	QTY	PART NO.	DESCRIPTION
1	1	7962-0104	SUBFRAME CONNECTOR, WELD-ON, DRIVER, 74-81 CAMARO/FIREBIRD
2	1	7962-0105	SUBFRAME CONNECTOR, WELD-ON, PSGR, 74-81 CAMARO/FIREBIRD
3	4	230140	CLAMPING BRKT, SBFRM CNCTR, 67-69 CMRO/FBIRD, 68-72 NOVA, S/M CLIP
4	4	3100-050F3.00Y	HEX BOLT, 1/2-20 x 3, GRADE 8, YELLOW ZINC
5	4	3101-050-20C	LOCKNUT, 1/2-20, GRADE 5, NYLON INSERT, CLEAR ZINC

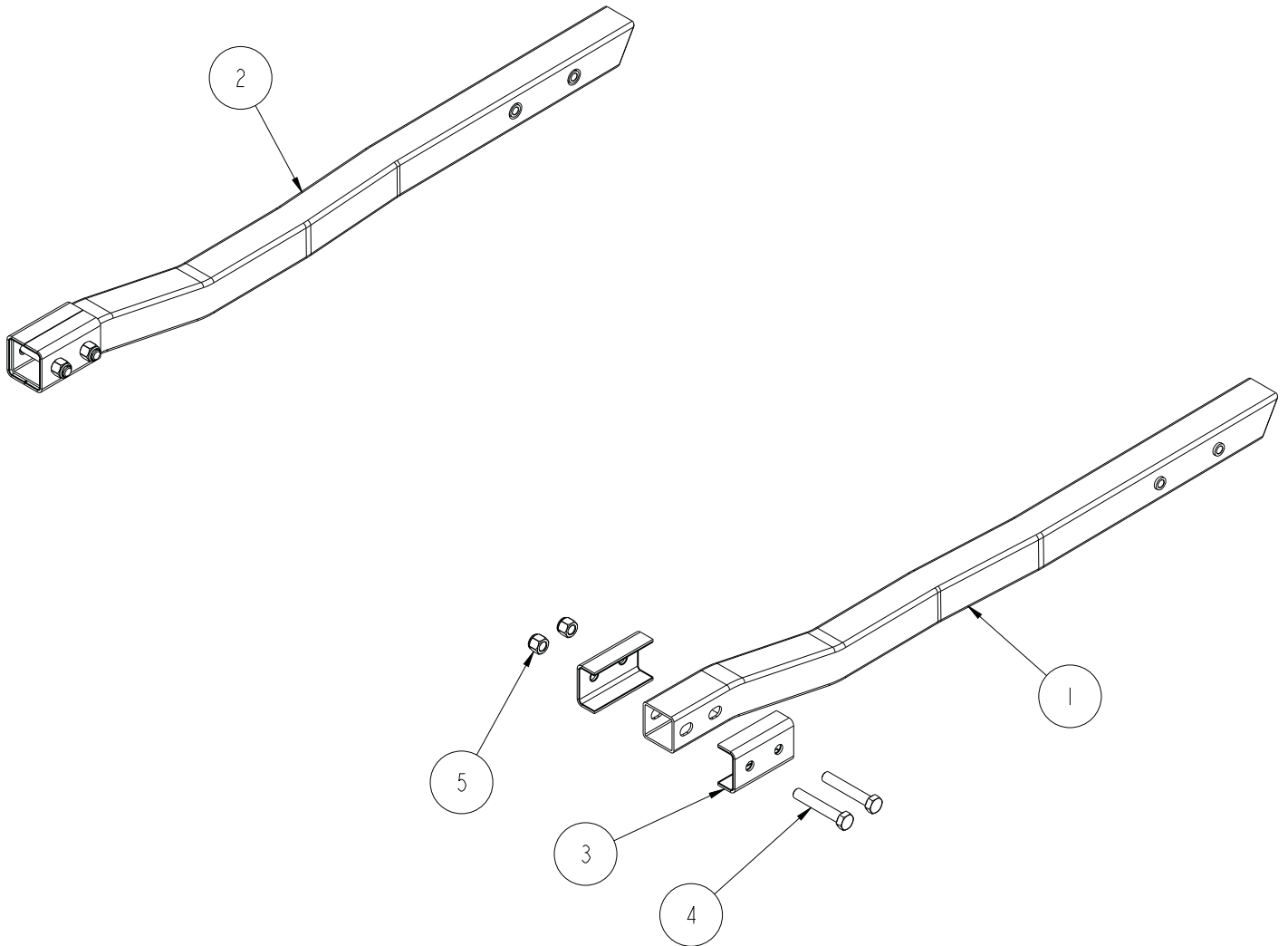

DESCRIPTION **SUBFRAME CONNECTORS, WELD-ON,
74-81 CAMARO/FIREBIRD**

Chris Aston's **CHASSISWORKS INC.**
8661 YOUNGER CREEK DRIVE
SACRAMENTO, CA 95828
(916) 388-0288 FAX 388-0295

PART NO.

5903-F22-NF

5/18/15

DWG: 7951-5903F22NF

PARTS LIST

5903-F22-NF - g-Connector Weld-in 74-81 Camaro/Firebird

Qty	Part Number	Description
1	7962-0104	Frame connector weld-in driver side F22
2	7962-0105	Frame connector weld-in passenger side F22
1	7952-5903F22NF	Hardware Bag

7952-5903F22NF - Hardware Bag

4	230140	Clamping bracket subframe connector
4	3100-050F3.00Y	Bolt 1/2-20 x 3" hex head cap screw
4	3101-050-20C	Locknut 1/2-20 nylon insert

INSTRUCTIONS

The new Chassiswork front frame clip or OEM frame clip with the adapters must be installed before proceeding.

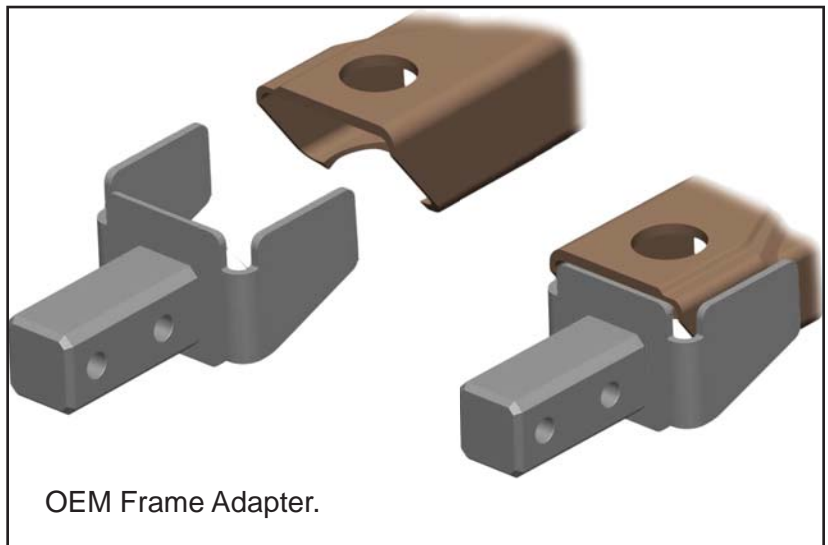

You will also need the Chassiswork rear frame installed before proceeding.



1. Raise and safely support the vehicle at the rocker panels.
2. Slide the driver side subframe connector over the front-clip frame rail. The slotted holes allow for any slight length differences from car to car.
3. Slide the two clamping brackets over the subframe connector. These are used to support the attachment between the subframe boss and the subframe connector.



4. Install the 1/2-20 x 3" hex bolts and locknuts. Do not fully tighten them at this time.



5. Raise the rear of the connector until it seats tight against the forward section of the new rear frame rail.



6. The connector should also be even with the rear frame right to left.
7. Tack weld the connector to the rear frame in 6-8 places.
8. Tighten the bolts at the front and torque to 45 lb-ft.

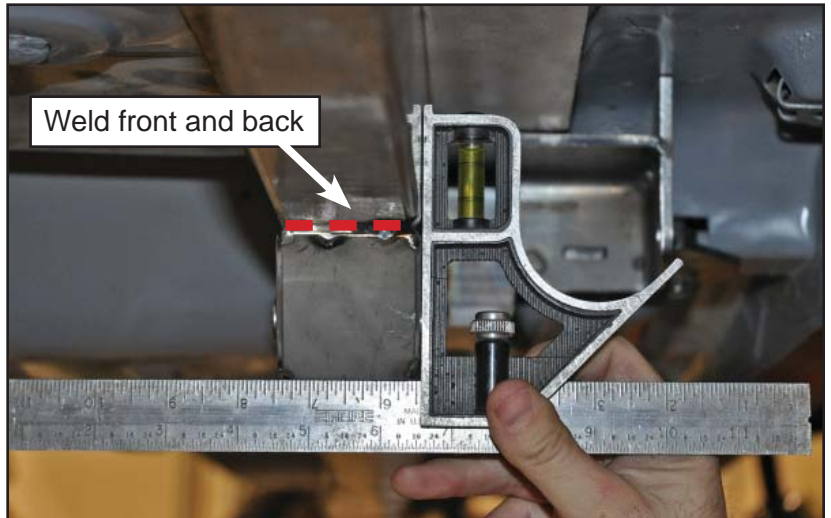

9. Weld the connector to the rear frame as marked in red. Weld the front, rear, inside and outside.

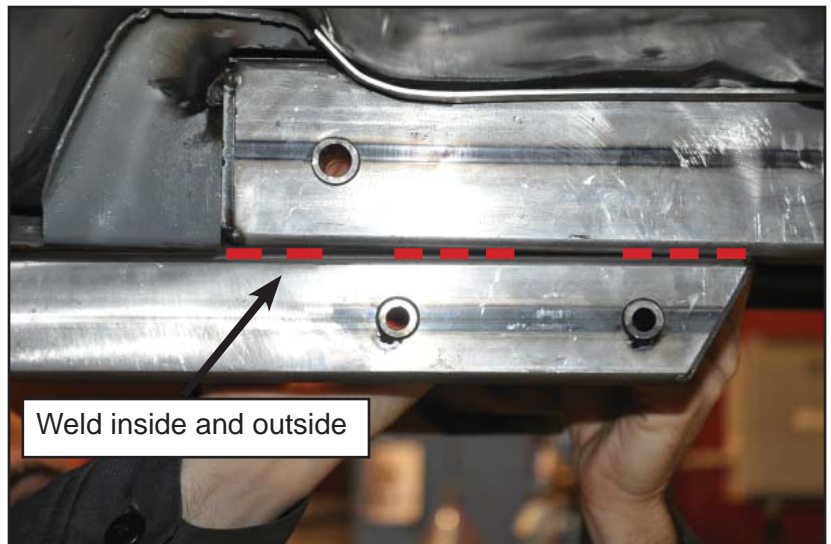

WARRANTY NOTICE:

There are NO WARRANTIES, either expressed or implied. Neither the seller nor manufacturer will be liable for any loss, damage or injury, direct or indirect, arising from the use or inability to determine the appropriate use of any products. Before any attempt at installation, all drawings and/or instruction sheets should be completely reviewed to determine the suitability of the product for its intended use. In this connection, the user assumes all responsibility and risk. We reserve the right to change specification without notice. Further, Chris Alston's Chassisworks, Inc., makes **NO GUARANTEE** in reference to any specific class legality of any component. **ALL PRODUCTS ARE INTENDED FOR RACING AND OFF-ROAD USE AND MAY NOT BE LEGALLY USED ON THE HIGHWAY.** The products offered for sale are true race-car components and, in all cases, require some fabrication skill. **NO PRODUCT OR SERVICE IS DESIGNED OR INTENDED TO PREVENT INJURY OR DEATH.**

Chris Alston's Chassisworks
8661 Younger Creek Drive
Sacramento, CA 95828
Phone: 916-388-0288
Technical Support: sales@cachassisworks.com

