

INSTALLATION GUIDE



6140-245

POWER RACK & PINION

FOR 33" WIDE STREET MACHINE CROSSMEMBER
USED ON 1967-1969 CAMARO AND FIREBIRDS,
1968-1972 NOVAS AND BUICK/OLDSMOBILE/PONTIAC

Note: This unit is only to be used with Chassisworks' power steering pump kits. The rack-and- pinion control valve flow requirements have been matched to the power steering pump we offer. Any other combination may yield undesirable results.

Rack-and-Pinion Specifications

Feature	Specification/Dimension
Rack Travel	3 turns lock to lock, 1.8" per turn, 5.375" total travel
Inner-Tie-Rod Thread	9/16-18 RH Male
Inner-Tie-Rod Length ¹	10.135"
Tie-Rod Assembly Length ²	13.283"
Input Shaft	16.8-mm DD
Hydraulic Fittings	-6 AN (pressure and return)
Recommended Pump Flow Rate	1.0 - 1.5 gpm (3.8 - 5.7 lpm)
Notes:	
1	Measured from tie-rod pivot center to end of threaded shaft.
2	Measured from center of inner- and outer-tie-rod pivots.

Specific Rack Dimensions

Callout	Feature	6140-245-X
A	Inner Pivot Width	24.50"
B	Overall Rack Width (no outer tie-rods)	44.75"
C	Overall Rack Width (with outer tie-rods)	51.00"

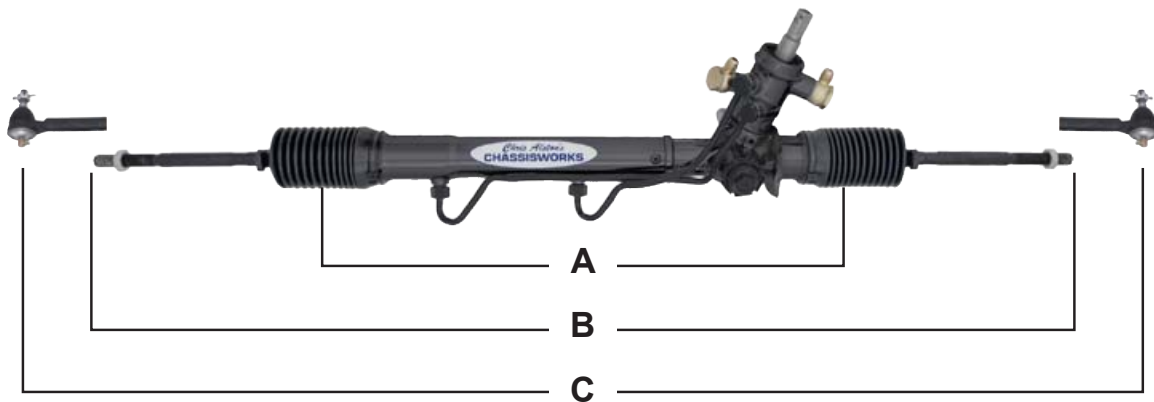

g-Machine Crossmember Dimensions

Callout	Feature	6140-245-X
D	g-Machine Crossmember Width	33"
E	Hub-to-Hub Width	60"

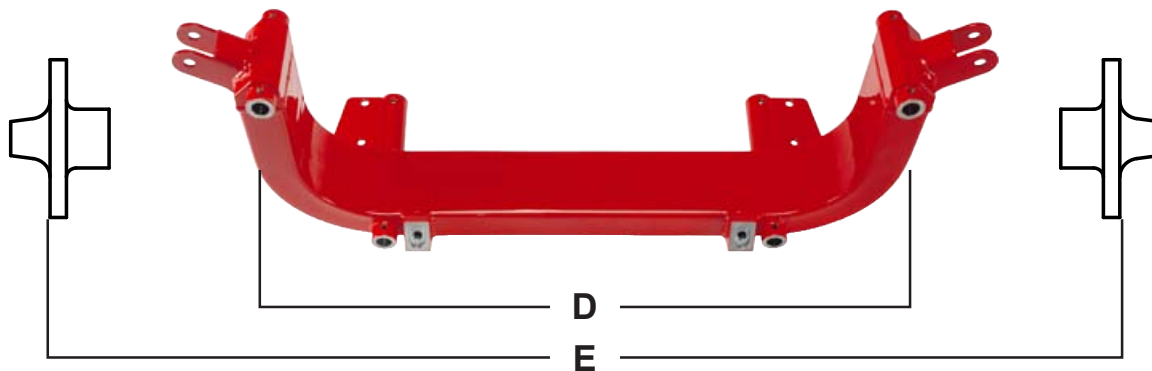

INSTRUCTIONS

Install Rack Mounts

1. Chase the threads in the rack-mounting bosses with a 1/2-13 tap before mounting the billet mounts (1469-X). The rack-mounting bosses are factory welded to the frame.
2. Position the billet mounts so the cupped surfaces face toward the center of the vehicle and bowed surfaces face toward the outside of vehicle.
3. Use the 1/2-13 x 2" socket head allen and 1/2" lock washer to mount the billet mount (1469-X) to the mounting boss. Use a small amount of Loctite™ on the socket head allen. The raised section on the back of the billet mount matches the milled recess on the mount bosses. Torque to 45 lb-ft.
4. Repeat the above procedure for the opposite side billet rack mount.



Install Rack

5. With the lower half of both rack mounts installed on the crossmember, set the rack into position.
6. One of the exclusive design features of our rack and mount is the ability to rotate the rack to provide any desired angle from the steering column to the rack input shaft. Rotate the rack to minimize the u-joint angle.
7. Push the rack firmly into each mount.
8. Secure the rack by installing the billet rack clamp caps (1469-X). Use the provided 5/16-18 x 1" stainless steel socket head allen and lock washer. Use a small amount of Loctite™ on the socket head allen. Tighten the cap with your T-handle allen wrench. Torque to 15 lb-ft.

Hook-up Hydraulic Hoses

9. The power steering hoses can now be hooked up to the rack & pinion.
10. Begin by installing the two banjo fittings into the appropriate size ports. Leave the fittings loose to allow rotation while hooking up and routing the hoses. Do not tighten hose ends at this time.

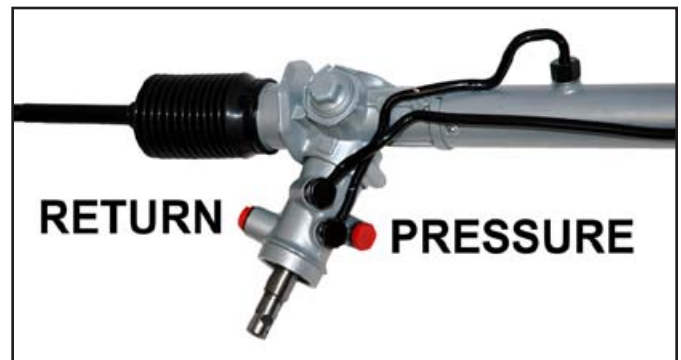

Pressure Port

Smaller port (M14 x 1.5), closest to center of vehicle

Return Port

Larger port (M16 x 1.5), closest to the wheel

11. Once hoses are correctly routed the banjo fittings can be tightened. Torque to 20 lb-ft.
12. Once Banjo fittings are tight the hose ends can be tightened. Torque to 20 lb-ft.

The next step will be aligning the front end. Refer to the main installation guide for specific instructions.

Related Components:

Steering Shaft & U-Joint Kits

- 6111 - For Aftermarket Steering Column
- 6188-PS - For OEM Column

Mounting Bracket Sets

- 6139-245-1 - Billet Aluminum, Satin Finish
- 6139-245-2 - Billet Aluminum, Polished Finish

Outer Tie Rod Sets

- 6177 - OEM Tie Rod Set
- 6151 - Bumpsteer Tie Rod Set

Power Steering Pump and Hose Kit

- 6138

WARRANTY NOTICE:

There are NO WARRANTIES, either expressed or implied. Neither the seller nor manufacturer will be liable for any loss, damage or injury, direct or indirect, arising from the use or inability to determine the appropriate use of any products. Before any attempt at installation, all drawings and/or instruction sheets should be completely reviewed to determine the suitability of the product for its intended use. In this connection, the user assumes all responsibility and risk. We reserve the right to change specification without notice. Further, Chris Alston's Chassisworks, Inc., makes **NO GUARANTEE** in reference to any specific class legality of any component. **ALL PRODUCTS ARE INTENDED FOR RACING AND OFF-ROAD USE AND MAY NOT BE LEGALLY USED ON THE HIGHWAY.** The products offered for sale are true race-car components and, in all cases, require some fabrication skill. **NO PRODUCT OR SERVICE IS DESIGNED OR INTENDED TO PREVENT INJURY OR DEATH.**

Chris Alston's Chassisworks, Inc.
8661 Younger Creek Drive
Sacramento, CA 95828
Phone: 916-388-0288
Technical Support: sales@cachassisworks.com



INSTALLATION GUIDE



6140-XXX

POWER RACK & PINION

IMPORTANT MOUNTING NOTE:

The two billet mounting clamp sets are end specific and must be mounted to the correct end of the rack and pinion. The clamp set with the chamfered (beveled) edges must be mounted closest to the rack's gear box with control servo. And, the non-chamfered clamp set must be mounted at the far end of the rack. Refer to the images below.

