

READ ALL INSTRUCTIONS COMPLETELY AND THOROUGHLY UNDERSTAND THEM BEFORE DOING ANYTHING.
CALL CHASSISWORKS TECH SUPPORT (916) 388-0288 IF YOU NEED ASSISTANCE.

INSTALLATION GUIDE

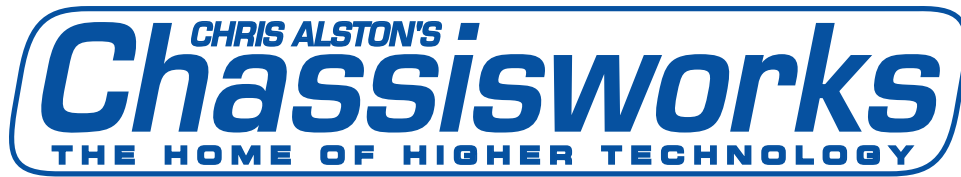

5735-SM33-12588

Splined Anti-roll Bar for Chassisworks

'67-81 Camaro/Firebird and 33" Wide Front Frame Clips



Description:

Bolt-on splined anti-roll bar for 1967-81 Camaros and Firebirds equipped with Chassisworks front clip. Includes tubular anti-roll bar, billet arms, endlink hardware for g-Machine or Street-Machine lower control arms. Bar spring rate is adjustable by moving upper end of endlink to one of three mounting holes at each arm.

| ITEM | QTY | PART NO. | DESCRIPTION |
|------|-----|-----------------|--|
| 1 | 2 | 7962-0120 | MOUNTING BLOCK, 3 WIDE, S/M HD ANTI-ROLL BAR |
| 2 | 2 | 7962-0122 | BUSHING HOUSING ASSEMBLY, \varnothing 1 1/4 BEARING |
| 3 | 1 | 7953G-3475A125J | ANTI-ROLL BAR, \varnothing 1 1/4 x \varnothing 7/8 BORE, 1 1/4-48 SERRATION x 34.75 LONG |
| 4 | 4 | 3108-038H-C | HIGH COLLAR LOCKWASHER, 3/8 STEEL, CLEAR ZINC |
| 5 | 4 | 3103-038C1.25C | SOCKET HEAD CAP SCREW, GRADE 8, 3/8-16 x 1 1/4, CLEAR ZINC |
| 6 | 1 | 7962-0117 | ARM, ANTI-ROLL BAR, LEFT, 1 1/4-48, S/M HD SUSPENSION |
| 7 | 8 | 3140-1216-008 | SLEEVE, \varnothing 1/2 x .384 x 1/4 |
| 8 | 2 | 3111-038X038-RT | ROD END, 3/8-24 RIGHT x 3/8 BORE, MALE, TEFLON, CM6T |
| 9 | 2 | 3108-031H-S | HIGH COLLAR LOCKWASHER, 5/16 INCH 18-8 STAINLESS |
| 10 | 2 | 3103-031F1.25C | SOCKET HEAD CAP SCREW, 5/16-24 x 1 1/4, CLEAR ZINC |
| 11 | 2 | 3127-038X038-RT | ROD END 3/8 x 3/8 BORE RIGHT, FEMALE, CF6T |
| 12 | 2 | 3102-038-24RC | JAM NUT, 3/8-24 RIGHT, CLEAR ZINC |
| 13 | 6 | 3109-038-S-2-Y | AIRCRAFT WASHER 3/8 x .062 THICK |
| 14 | 2 | 3100-038F2.25Y | HEX BOLT, 3/8-24 x 2 1/4, GRADE 8, YELLOW ZINC |
| 15 | 2 | 3101-038-24C | LOCKNUT, 3/8-24, GRADE 5, NYLON INSERT, CLEAR ZINC |
| 16 | 2 | 3108-038L-C | LOCK WASHER, HELICAL SPRING \varnothing 3/8, STEEL, ZINC |
| 17 | 2 | 3103-038F1.75C | SOCKET HEAD CAP SCREW, GRADE 8, 3/8-24 x 1 3/4, CLEAR ZINC |
| 18 | 1 | 7962-0118 | ARM, ANTI-ROLL BAR, RIGHT, 1 1/4-48, S/M HD SUSPENSION |

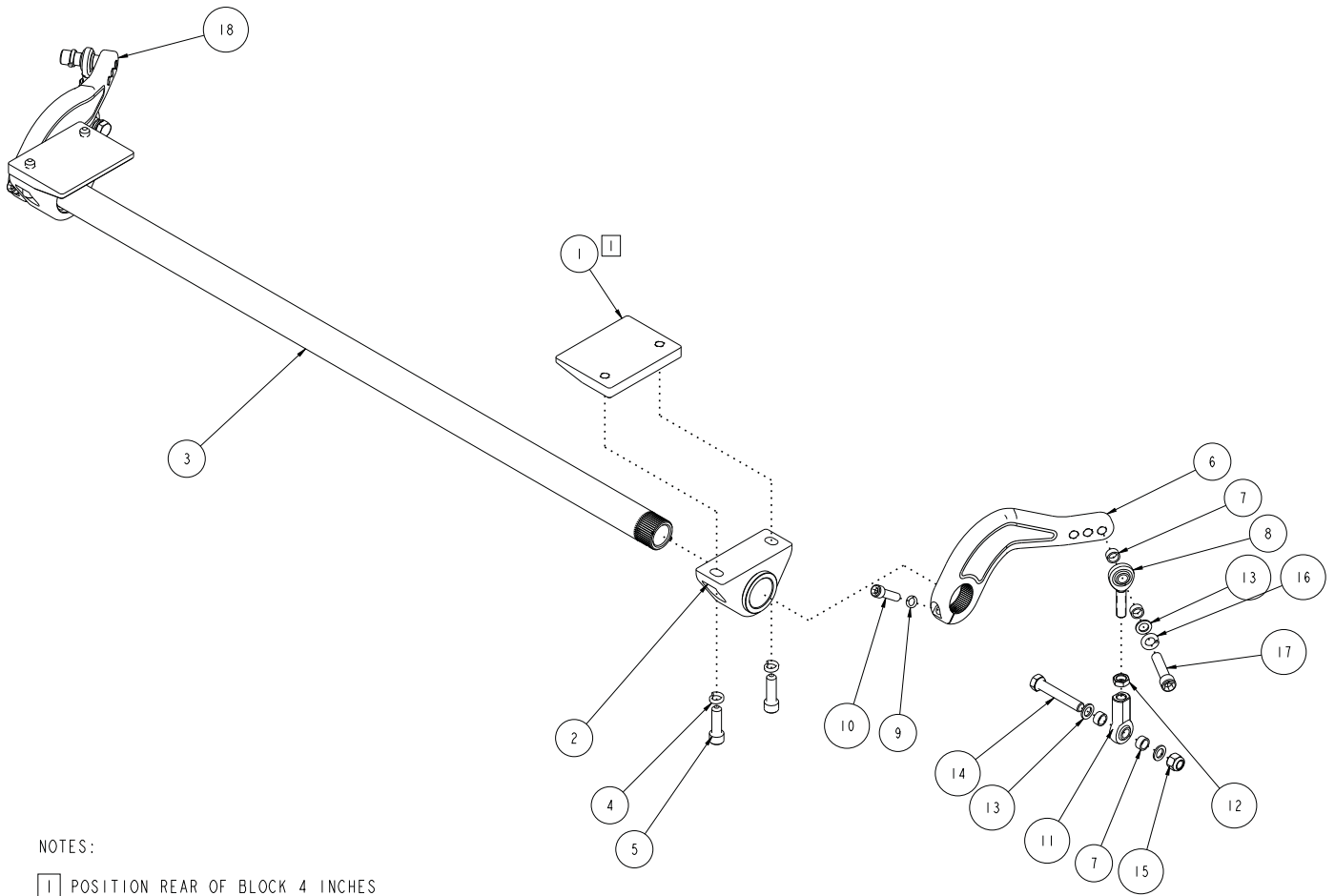

NOTES:

1 POSITION REAR OF BLOCK 4 INCHES FROM FRONT OF CROSSMEMBER AND FLUSH WITH OUTSIDE OF FRAME.

MARK AND DRILL 7/16 CLEARANCE HOLES IN FRAME TO CLEAR SCREW

| | | |
|--|--|------------------------|
| DESCRIPTION | ANTI-ROLL BAR ASSEMBLY, 33 FRAME WIDTH, 3 WIDE FRAME RAIL | |
| <i>Chris Nelson's CHASSISWORKS INC.</i> 8661 YOUNGER CREEK DRIVE SACRAMENTO, CA 95826 (916) 368-0268 FAX 368-0295 | PART NO. | 5735-SM33-12588 |
| | 9/2/16 | DWG: 5735-SM33-12588 |

PARTS LIST

5735-SM33-12588 - Splined Anti-Roll Bar for Chassisworks '67-81 Camaro Front Clip

| Qty | Part Number | Description |
|-----|-----------------|--|
| 1 | 7952-5735 | Hardware bag |
| 1 | 7962-0117 | Anti-roll bar left arm 1-1/4"-48 x 6.5" |
| 1 | 7962-0118 | Anti-roll bar right arm 1-1/4"-48 x 6.5" |
| 2 | 7962-0122 | Anti-roll bar bushing assembly |
| 1 | 7953G-3475A125J | Splined anti-roll bar 1-1/4"-48 x .88" wall x 34.75" |

7952-5735 - Hardware Bag

| Qty | Part Number | Description |
|-----|-----------------|---|
| 2 | 3100-038F2.25Y | Bolt 3/8-24 x 2-1/4" hex head cap screw |
| 2 | 3101-038-24C | Locknut 3/8-24 nylon insert |
| 2 | 3102-038-24RC | Jam nut 3/8-24 RH |
| 2 | 3103-031F1.25C | Allen head 5/16-24 x 1-1/4" socket head cap screw |
| 4 | 3103-038C1.25C | Allen head 3/8-16 x 1-1/4" socket head cap screw |
| 2 | 3103-038F1.75C | Allen head 3/8-24 x 1-3/4" socket head cap screw |
| 2 | 3108-031H-S | Lock washer 5/16" high collar |
| 4 | 3108-038H-C | Lock washer 3/8" high collar |
| 2 | 3108-038L-C | Lock washer 3/8" regular |
| 6 | 3109-038-S-2-Y | Aircraft washer 3/8" small OD |
| 2 | 3111-038X038-RT | Rod end 3/8-24 RH male x 3/8" bore |
| 2 | 3127-038X038-RT | Rod end 3/8-24 RH female x 3/8" bore |
| 8 | 3140-1216-008 | Sleeve 3/8" ID x 1/2" OD x 1/4" long |

OPTION - Weld-On Frame Adapters (Retrofits existing Chassisworks clip with mounts)

| Qty | Part Number | Description |
|-----|-------------|---|
| 2 | 7962-0120 | Anti-roll bar mounting block with threaded bosses |

OPTION - 7950-5735-SM - Endlink Hardware for Stem-Style Lower Control Arms

| Qty | Part Number | Description |
|-----|-----------------|--|
| 4 | 2042 | Endlink grommet washer |
| 2 | 3103-038F3.00C | Allen head 3/8-24 x 3" socket head cap screw |
| 2 | 3108-038L-C | Lock washer 3/8" regular |
| 2 | 3140-1224-024 | Sleeve 3/8" ID x 3/4" OD x 3/4" long |
| 1 | 3151-5ML | Poly lube 5ml tube |
| 4 | 3153-38.70-37-B | Bushing 3/8" bore with .70" nipple |

INSTRUCTIONS

1. Slide the bearing housing mount over the bar end. The bearing flange must face outward.
2. The splined bar end features a machined groove that must be aligned with the pinch bolt in the billet arm.

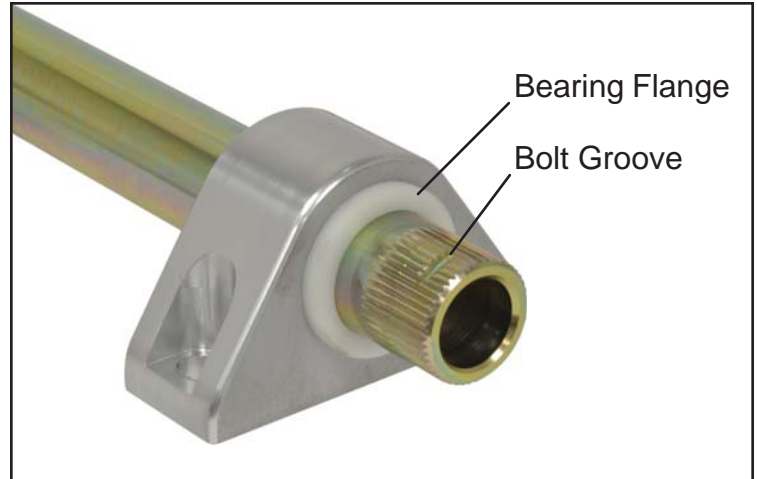

3. Clock the arm so that the collar split is centered over the bolt groove and slide the arm into position. A light lubricant can be used to allow easier assembly. If the the arm is not correctly indexed, the pinch bolt will not fit through the hole.
4. Use a small amount of Loctite® on the threads and tighten the pinch bolt. This pinch-bolt configuration applies pressure against the spline to remove all play.
5. Repeat procedure for opposite bar end.
6. After the second arm has been installed, place the bar on a flat surface to ensure the arms are square.

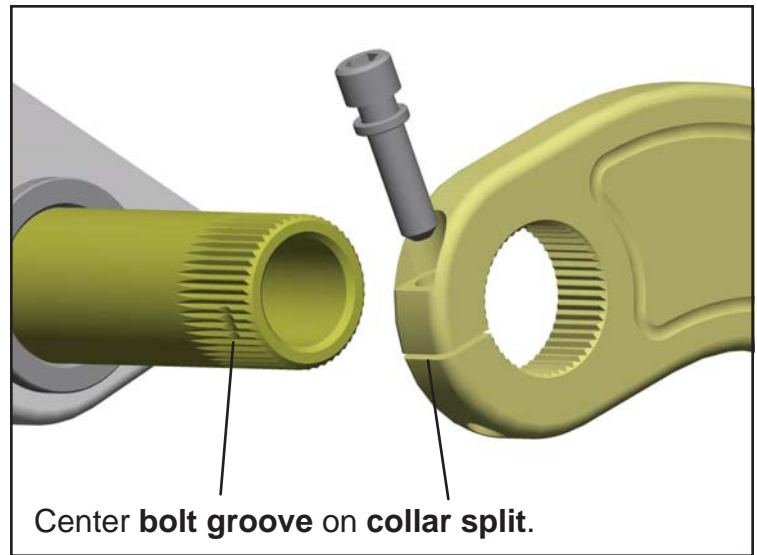

7. The anti-roll bar can now be bolted onto the clip and the endlinks assembled as shown in the assembly diagram.



Retrofitting Existing Chassisworks Clip

The billet mounting frame plates (7962-0120) can be optionally selected with the anti-roll bar kit. Retrofitting the plates to an existing front clip requires welding. Refer to the drawing below for correct orientation and placement.

1. Place the bearing housing mounts over the splined bar as shown in step one on previous page.
2. Bolt the bearing mounts to the frame plates. The anti-roll bar is used as a welding jig to ensure the frame plates are correctly aligned. Do not screw the bolts in passed the backside of the frame plate so that the frame plate sits flat against the frame rail.
3. Clamp the assembly to the underside of the frame rail. **The frame plate must be centered on the frame rail and it's rear edge 4" from the front of the suspension crossmember.**
4. Once correctly positioned, tack weld the frame plates in multiple locations to prevent it from shifting when welding. If the bracket shifts during welding the bearings will not be correctly aligned making installation difficult.
5. Remove the bearing mounts and anti-roll bar before completely welding the frame plates.
6. After the welds have completely cooled pilot holes must be drilled through the bottom of the frame rail at the threaded hole locations.
7. Use a 3/8-16 tap to extend the mounting plate threads into the bottom wall of the frame rail.
8. The frame clip should then be painted and the anti-roll bar installed as shown in the assembly diagram.

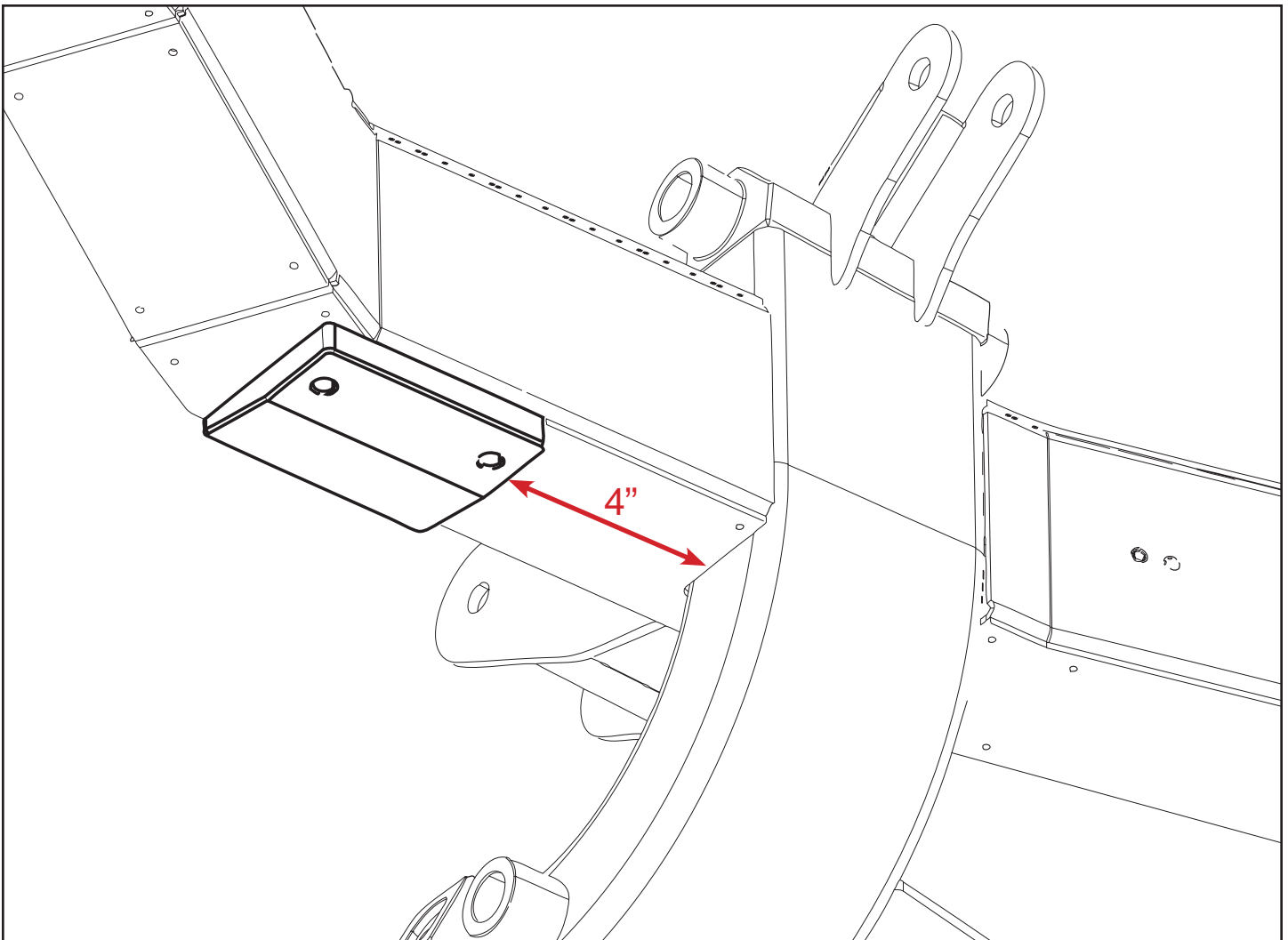

WARRANTY NOTICE:

There are NO WARRANTIES, either expressed or implied. Neither the seller nor manufacturer will be liable for any loss, damage or injury, direct or indirect, arising from the use or inability to determine the appropriate use of any products. Before any attempt at installation, all drawings and/or instruction sheets should be completely reviewed to determine the suitability of the product for its intended use. In this connection, the user assumes all responsibility and risk. We reserve the right to change specification without notice. Further, Chris Alston's Chassisworks, Inc., makes **NO GUARANTEE** in reference to any specific class legality of any component. **ALL PRODUCTS ARE INTENDED FOR RACING AND OFF-ROAD USE AND MAY NOT BE LEGALLY USED ON THE HIGHWAY.** The products offered for sale are true race-car components and, in all cases, require some fabrication skill. **NO PRODUCT OR SERVICE IS DESIGNED OR INTENDED TO PREVENT INJURY OR DEATH.**

Chris Alston's Chassisworks
8661 Younger Creek Drive
Sacramento, CA 95828
Phone: 916-388-0288
Technical Support: tech@cachassisworks.com

