

ITEM	QTY	PART NO.	DESCRIPTION
1	2	899-040-102	CLAMP, ϕ 2.225 RESERVOIR, FLAT SURFACE x 1/2
2	2	3108-025H-C	HIGH COLLAR LOCKWASHER, 1/4 STEEL, CLEAR ZINC
3	2	3103-025C1.00C	SOCKET HEAD CAP SCREW, 1/4-20 x 1, CLEAR ZINC
4	4	3108-025L-C	LOCK WASHER, HELICAL SPRING ϕ 1/4, STEEL, ZINC
5	4	3104-025C0.63C	BUTTON HEAD SOCKET CAP SCREW, 1/4-20 x 5/8, CLEAR ZINC

VARISHOCK REMOTE RESERVOIR
NOT INCLUDED IN KIT

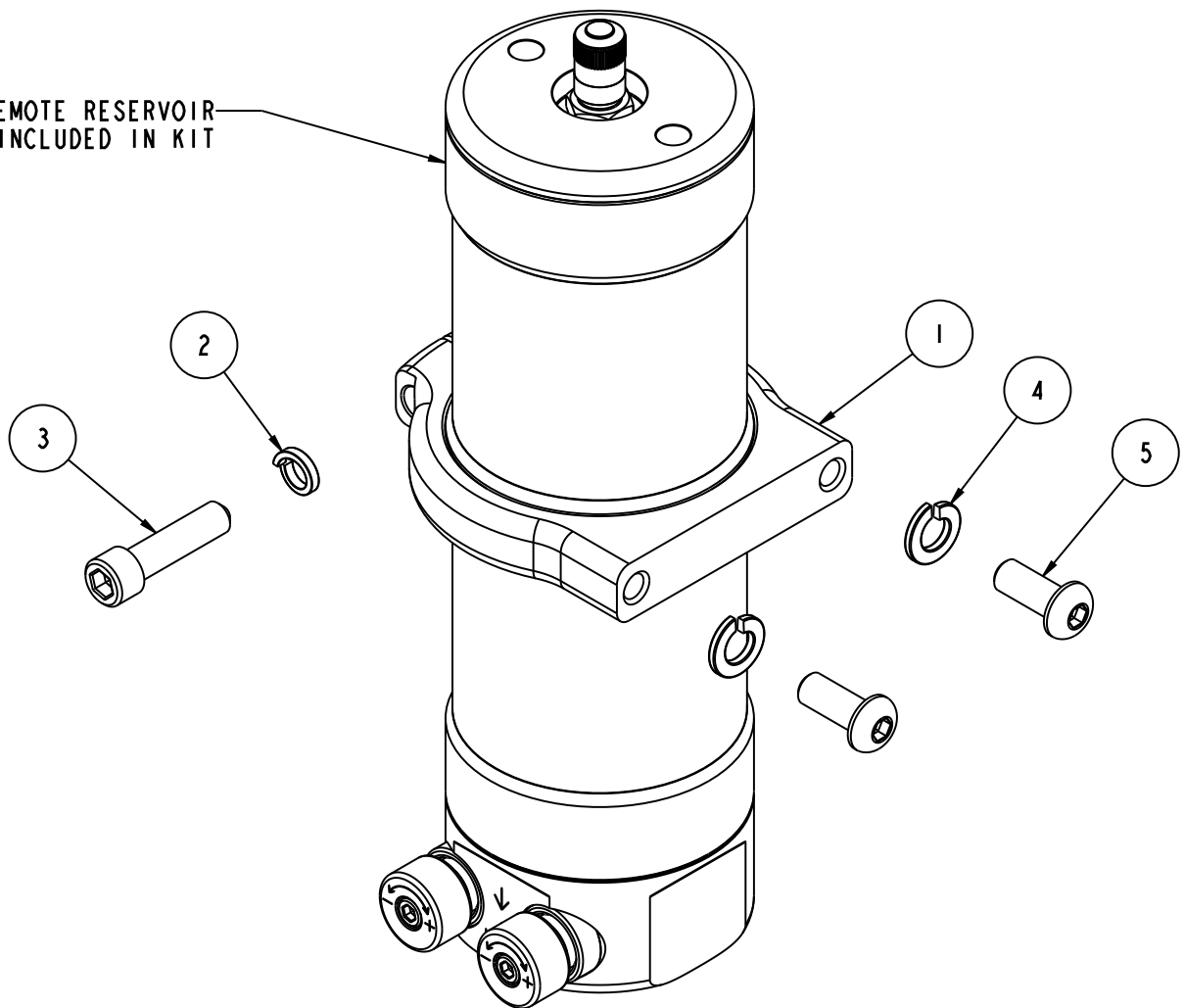

DRILL 17/64 HOLES ON 2 IN CENTERS
TO ATTACH RESERVOIR CLAMP

DESCRIPTION		CLAMP, RESERVOIR, FLAT STYLE, ϕ2.225 RESERVOIR BODY x FLAT SURFACE	
Chris Alston's CHASSISWORKS INC. 8661 YOUNGER CREEK DRIVE SACRAMENTO, CA 95828 (916) 388-0288 FAX 388-0295		PART NO. VAS 516-01-000	
		2/22/10	DWG: 899-031-247

WARRANTY NOTICE:

There are NO WARRANTIES, either expressed or implied. Neither the seller nor manufacturer will be liable for any loss, damage or injury, direct or indirect, arising from the use or inability to determine the appropriate use of any products. Before any attempt at installation, all drawings and/or instruction sheets should be completely reviewed to determine the suitability of the product for its intended use. In this connection, the user assumes all responsibility and risk. We reserve the right to change specification without notice. Further, Chris Alston's Chassisworks, Inc., makes **NO GUARANTEE** in reference to any specific class legality of any component. **ALL PRODUCTS ARE INTENDED FOR RACING AND OFF-ROAD USE AND MAY NOT BE LEGALLY USED ON THE HIGHWAY.** The products offered for sale are true race-car components and, in all cases, require some fabrication skill. **NO PRODUCT OR SERVICE IS DESIGNED OR INTENDED TO PREVENT INJURY OR DEATH.**

Chris Alston's Chassisworks
8661 Younger Creek Drive
Sacramento, CA 95828
Phone: 916-388-0288
Technical Support: tech@cachassisworks.com

