

READ ALL INSTRUCTIONS COMPLETELY AND THOROUGHLY UNDERSTAND THEM BEFORE DOING ANYTHING.  
CALL KP COMPONENTS TECH SUPPORT (916) 388-0288 IF YOU NEED ASSISTANCE.

## INSTALLATION GUIDE



### KPC FCB-C41

Air-Bag Style Dropped Crossmember  
1973-1987 Chevrolet C10 Pickup

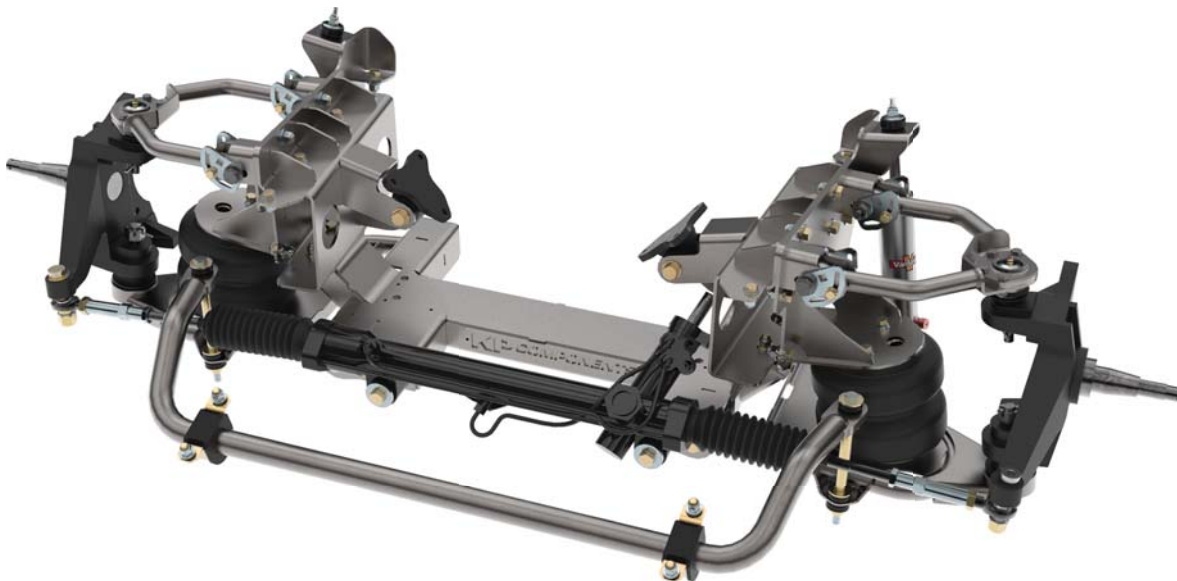

**Description:**

Bolt-on dropped crossmember with shock and air-bag mounts. Requires suspension and steering package to complete installation.

----- SPECIAL ORDER PART NOT CANCELABLE OR RETURNABLE FOR ANY REASON -----

**Diagram 1**

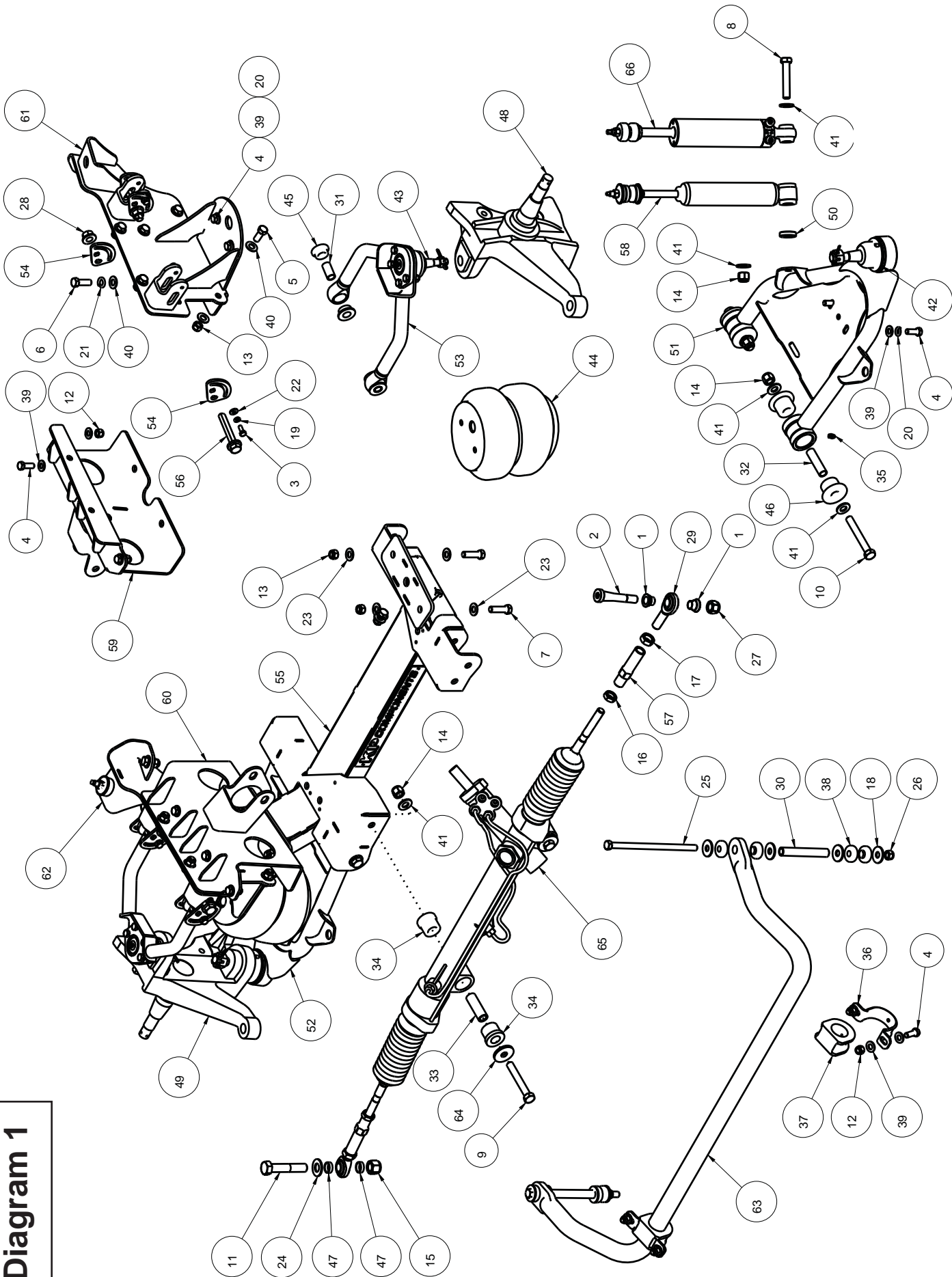

## Diagram 1 - Parts List (1 of 2)

ITEM	QTY	PART NO.	DESCRIPTION
1	4	1284	MISALIGNMENT BUSHING, STEERING STUD, 60-87 GM C10 DROPPED CROSSMEMBER
2	2	1285	STEERING STUD, REVERSE STYLE, 5/8-18 UNF, 73-86 GM C10 DROPPED CROSSMEMBER
3	8	3100-025F0.63Y	HEX BOLT, 1/4-28 x 5/8, GRADE 8, YELLOW ZINC
4	16	3100-038C1.00Y	HEX BOLT, 3/8-16 x 1, GRADE 8, YELLOW ZINC
5	16	3100-044C1.00Y	HEX BOLT, 7/16-14 x 1, GRADE 8, YELLOW ZINC
6	2	3100-044C1.25Y	HEX BOLT, 7/16-14 x 1 1/4, GRADE 8, YELLOW ZINC
7	4	3100-044C1.50Y	HEX BOLT, 7/16-14 x 1 1/2, GRADE 8, YELLOW ZINC
8	1	3100-050C2.75Y	HEX BOLT, 1/2-13 x 2 3/4, GRADE 8, YELLOW ZINC
9	2	3100-050C3.50Y	HEX BOLT, 1/2-13 x 3 1/2, GRADE 8, YELLOW ZINC
10	2	3100-050C3.75Y	HEX BOLT, 1/2-13 x 3 3/4, GRADE 8, YELLOW ZINC
11	1	3100-063C3.25Y	HEX BOLT, 5/8-11 x 3 1/4, GRADE 8, YELLOW ZINC
12	10	3101-038-16C	LOCKNUT 3/8-16, GRADE 5, NYLON INSERT, CLEAR ZINC
13	20	3101-044-14C	LOCKNUT 7/16-14, GRADE 5 NYLON INSERT, CLEAR ZINC
14	5	3101-050-13C	LOCKNUT 1/2-13, GRADE 5, NYLON INSERT, CLEAR ZINC
15	1	3101-063-11C	LOCKNUT 5/8-11, GRADE 5, NYLON INSERT, CLEAR ZINC
16	2	3102-056-18RC	JAM NUT, 9/16-18 RIGHT, CLEAR ZINC
17	2	3102-063-18LY	JAM NUT, 5/8-18 LEFT, YELLOW ZINC
18	8	3107-044U-Y	WASHER, 7/16 USS, GRADE 9, 1.240 OD, .454 ID, .106 THK, YELLOW ZINC
19	8	3108-025L-C	LOCK WASHER, HELICAL SPRING $\phi$ 1/4, STEEL, ZINC
20	6	3108-038L-C	LOCK WASHER, HELICAL SPRING $\phi$ 3/8, STEEL, ZINC
21	2	3108-044L-C	LOCK WASHER, HELICAL SPRING $\phi$ 7/16, STEEL, ZINC
22	8	3120-025S-Y	FLAT WASHER, 1/4 SAE, HARDENED, YELLOW ZINC
23	8	3120-044S-Y	FLAT WASHER, 7/16 SAE, HARDENED, YELLOW ZINC
24	1	3120-063S-Y	FLAT WASHER, 5/8 SAE, HARDENED, YELLOW ZINC
25	2	3123-044C8.00C	HEX BOLT, 7/16-14 x 8, GRADE 5, CLEAR ZINC
26	2	3131-044-20Y	LOCKNUT 7/16-20, GRADE 8, NYLON INSERT, YELLOW ZINC
27	1	3131-056-18Y	LOCKNUT, 9/16-18, GRADE 8, NYLON INSERT, YELLOW ZINC
28	4	3132-050-13P	FLANGED TOP LOCKNUT, 1/2-13, GRADE G, PHOSPHATE AND OIL
29	2	3136-063X063-LT	ROD END, 5/8-18 LEFT x 5/8 BORE CMX10T-F1
30	2	3140-1420-136	SLEEVE, $\phi$ 5/8 x 7/16 x 4.25 LONG
31	4	3140-1620-040	SLEEVE, POLY BUSHING, $\phi$ 5/8 x 1/2 x 1.25
32	2	3140-1620-077	SLEEVE, POLY BUSHING, $\phi$ 5/8 x 1/2 x 2.406
33	2	3140-1624-074	SLEEVE, POLY BUSHING $\phi$ 3/4 x 1/2 x 2.313
34	4	3141-2442-1.20	POLYURETHANE BUSHING 1.503 FLANGE x 1.302 BARREL x .758 BORE
35	2	3144-25-28-0	GREASE ZERK 1/4-28 STRAIGHT
36	2	3150-F-CLAMP-G	SWAY BAR F STRAP CLAMP, GREASABLE
37	2	3150-F1.38-B	POLYURETHANE BUSHING, 1 3/8 SWAY BAR, BLACK
38	8	3153-44.60-40-B	POLY BUSHING, 7/16 STEM MOUNT, $\phi$ .59 NIPPLE x $\phi$ 1.25 OD, BLACK
39	26	3157-038S-C	WASHER, 3/8 SAE, ZINC PLATED, 13/32 ID x 13/16 OD x 1/16 THICK,
40	34	3157-044S-C	WASHER, 7/16 SAE, ZINC PLATED, 7/16 ID x 1 1/8 OD x 1/16 THICK

# Diagram 1 - Parts List (2 of 2)

41	8	3157-050S-C	WASHER, 1/2 SAE, ZINC PLATED, 1/2 ID x 1 1/16 OD x 3/32 THICK
42	1	3164-FA1014	BALLJOINT, LOWER, 1971-87 CHEVROLET C10
43	2	3164-FA903	BALLJOINT, UPPER, 1973-87 CHEVROLET C10
44	2	3470-SS7	AIR BAG, 7" OD x 250 PSI, 1/2 NPT
45	8	3533	POLYURETHANE BUSHING 1.0 x .625 x .400
46	4	3540	POLYURETHANE BUSHING, 1.375 x .625 x .95
47	2	7900-226-.250	SPACER, $\phi$ .813 OD x $\phi$ .646 ID x .250 LONG
48	1	7919-026	SPINDLE, 3" DROP, DRV, 73-87 C10
49	1	7919-027	SPINDLE, 3" DROP, PSGR, 73-87 C10
50	1	7931-084	SPACER, $\phi$ 1 1/4 OD x $\phi$ 1/2 ID x .300 LONG
51	1	7933-110	LOWER CONTROL ARM WELDMENT, DRIVER, 60-87 GM C10 DROPPED CROSSMEMBER
52	1	7933-113	LOWER CONTROL ARM ASSY, PSGR, 71-87 GM C10 DROPPED CROSSMEMBER
53	2	7933-116	UPPER CONTROL ARM WELDMENT, DRV/PSGR, 60-87 GM C10 DROPPED CROSSMEMBER
54	8	7933-129	ALIGNMENT CAM, UPPER CONTROL ARM, GM C10 DROPPED CROSSMEMBER
55	1	7933-130	DROPPED CROSSMEMBER WELDMENT, 63-72 GM C10
56	4	7933-136	CAM BOLT, 1/2-13 x 4, GM C10 DROPMEMBER
57	2	7933-147	TIE ROD ADAPTER, 9/16-18 RH x 5/8-18 LH, 3.688 OAL
58	2	7933-148	SHOCK ABSORBER, 5.25 TRAVEL, MONROE 32250
59	1	7933-164	CROSSMEMBER BRACKET, INNER DRV, 73-87 GM C10 DROPPED CROSSMEMBER
60	1	7933-165	CROSSMEMBER BRACKET, INNER PSGR, 73-87 GM C10 DROPPED CROSSMEMBER
61	1	7933-166	UCA/AIRBAG MOUNT ASSEMBLY, DRIVER, 73-87 GM C10 DROPPED CROSSMEMBER
62	1	7933-167	UCA/AIRBAG MOUNT ASSEMBLY, PASSENGER, 73-87 GM C10 DROPPED CROSSMEMBER
63	1	7933-171	ARB, $\phi$ 1 3/8 SOLID, FRONT, DROPPED CROSSMEMBER 60-87 C10
64	2	7972-2599	WASHER, $\phi$ 1.60 x $\phi$ 1/2 x .180 THICK
65	1	KPC RP-DC	POWER RACK, 9/16-18 RH TIE ROD ENDS, 60-87 GM C10 DROPPED CROSSMEMBER
66	2	VAS 12242-515	S/B Q2, 63 SPOOL x STEM-B, 5.15 TRAVEL

DESCRIPTION		DROPPED CROSSMEMBER, 1973-87 CHEVROLET/GMC C10	
<i>Chris Alston's</i> <b>CHASSISWORKS INC.</b> 8661 YOUNGER CREEK DRIVE SACRAMENTO, CA 95828 (916) 388-0288 FAX 388-0295		PART NO. <b>KPC FCB-C41</b>	
		1/30/20	DWG: KPC_FCB-C41

## Diagram 2

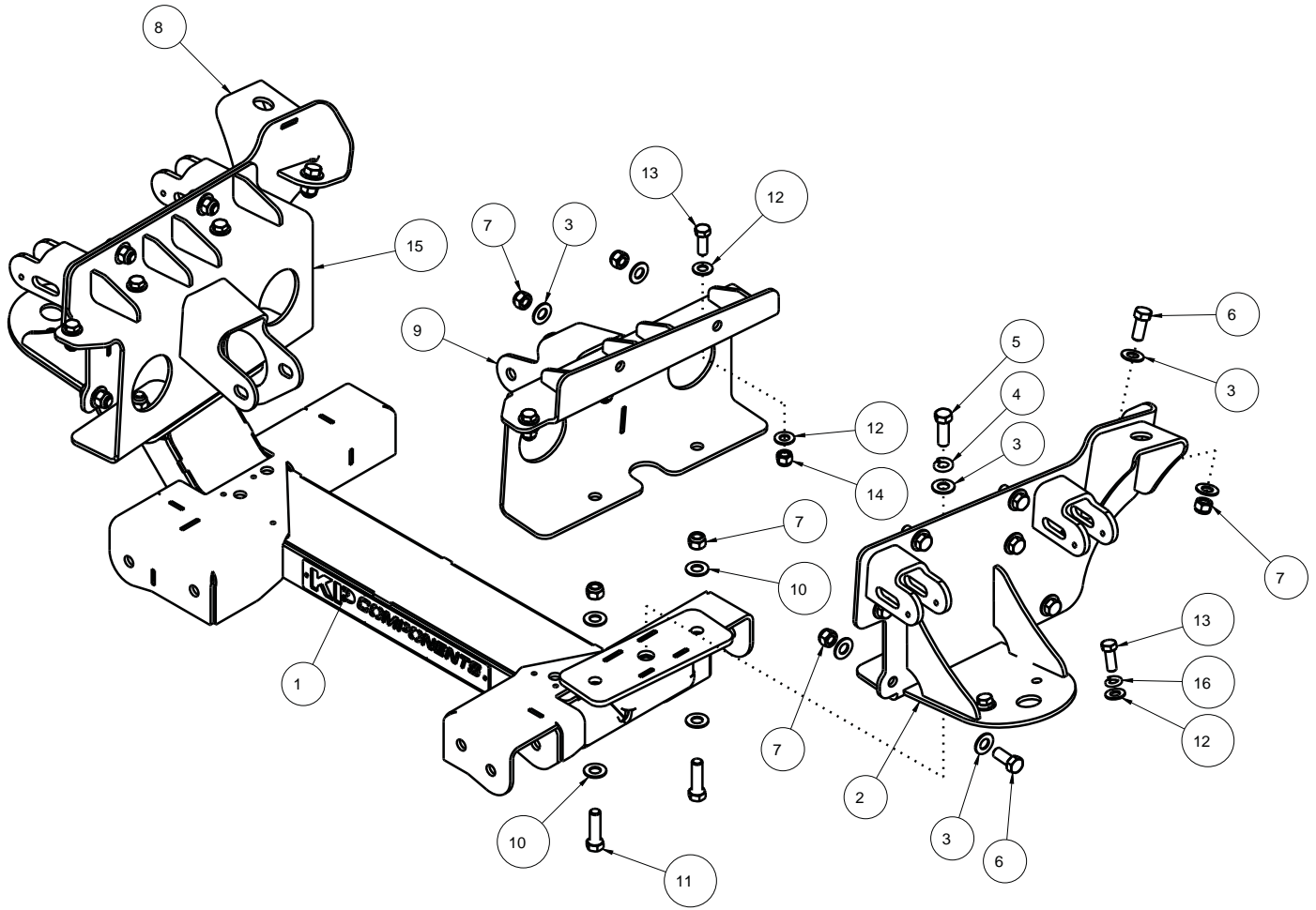

ITEM	QTY	PART NO.	DESCRIPTION
1	1	7933-130	DROPPED CROSSMEMBER WELDMENT, 63-72 GM C10
2	1	7933-166	UCA/AIRBAG MOUNT ASSEMBLY, DRIVER, 73-87 GM C10 DROPPED CROSSMEMBER
3	34	3157-044S-C	WASHER, 7/16 SAE, ZINC PLATED, 7/16 ID x 1 1/8 OD x 1/16 THICK
4	2	3108-044L-C	LOCK WASHER, HELICAL SPRING $\varnothing$ 7/16, STEEL, ZINC
5	2	3100-044C1.25Y	HEX BOLT, 7/16-14 x 1 1/4, GRADE 8, YELLOW ZINC
6	16	3100-044C1.00Y	HEX BOLT, 7/16-14 x 1, GRADE 8, YELLOW ZINC
7	20	3101-044-14C	LOCKNUT 7/16-14, GRADE 5 NYLON INSERT, CLEAR ZINC
8	1	7933-167	UCA/AIRBAG MOUNT ASSEMBLY, PASSENGER, 73-87 GM C10 DROPPED CROSSMEMBER
9	1	7933-164	CROSSMEMBER BRACKET, INNER DRV, 73-87 GM C10 DROPPED CROSSMEMBER
10	8	3120-044S-Y	FLAT WASHER, 7/16 SAE, HARDENED, YELLOW ZINC
11	4	3100-044C1.50Y	HEX BOLT, 7/16-14 x 1 1/2, GRADE 8, YELLOW ZINC
12	16	3157-038S-C	WASHER, 3/8 SAE, ZINC PLATED, 13/32 ID x 13/16 OD x 1/16 THICK,
13	10	3100-038C1.00Y	HEX BOLT, 3/8-16 x 1, GRADE 8, YELLOW ZINC
14	6	3101-038-16C	LOCKNUT 3/8-16, GRADE 5, NYLON INSERT, CLEAR ZINC
15	1	7933-165	CROSSMEMBER BRACKET, INNER PSGR, 73-87 GM C10 DROPPED CROSSMEMBER
16	4	3108-038L-C	LOCK WASHER, HELICAL SPRING $\varnothing$ 3/8, STEEL, ZINC

ITEM	QTY	PART NO.	DESCRIPTION
1	2	7901-064	FABRICATED MOTOR MOUNT ASSY GM SMALL BLOCK/BIG BLOCK
2	6	3157-038S-C	WASHER, 3/8 SAE, ZINC PLATED, 13/32 ID x 13/16 OD x 1/16 THICK,
3	6	3108-038L-C	LOCK WASHER, HELICAL SPRING $\varnothing$ 3/8, STEEL, ZINC
4	6	3100-038C1.25Y	HEX BOLT, 3/8-16 x 1 1/4, GRADE 8, YELLOW ZINC
5	4	3120-050S-Y	FLAT WASHER, 1/2 SAE, HARDENED, YELLOW ZINC
6	2	3100-050C3.75Y	HEX BOLT, 1/2-13 x 3 3/4, GRADE 8, YELLOW ZINC
7	2	3101-050-13C	LOCKNUT 1/2-13, GRADE 5, NYLON INSERT, CLEAR ZINC

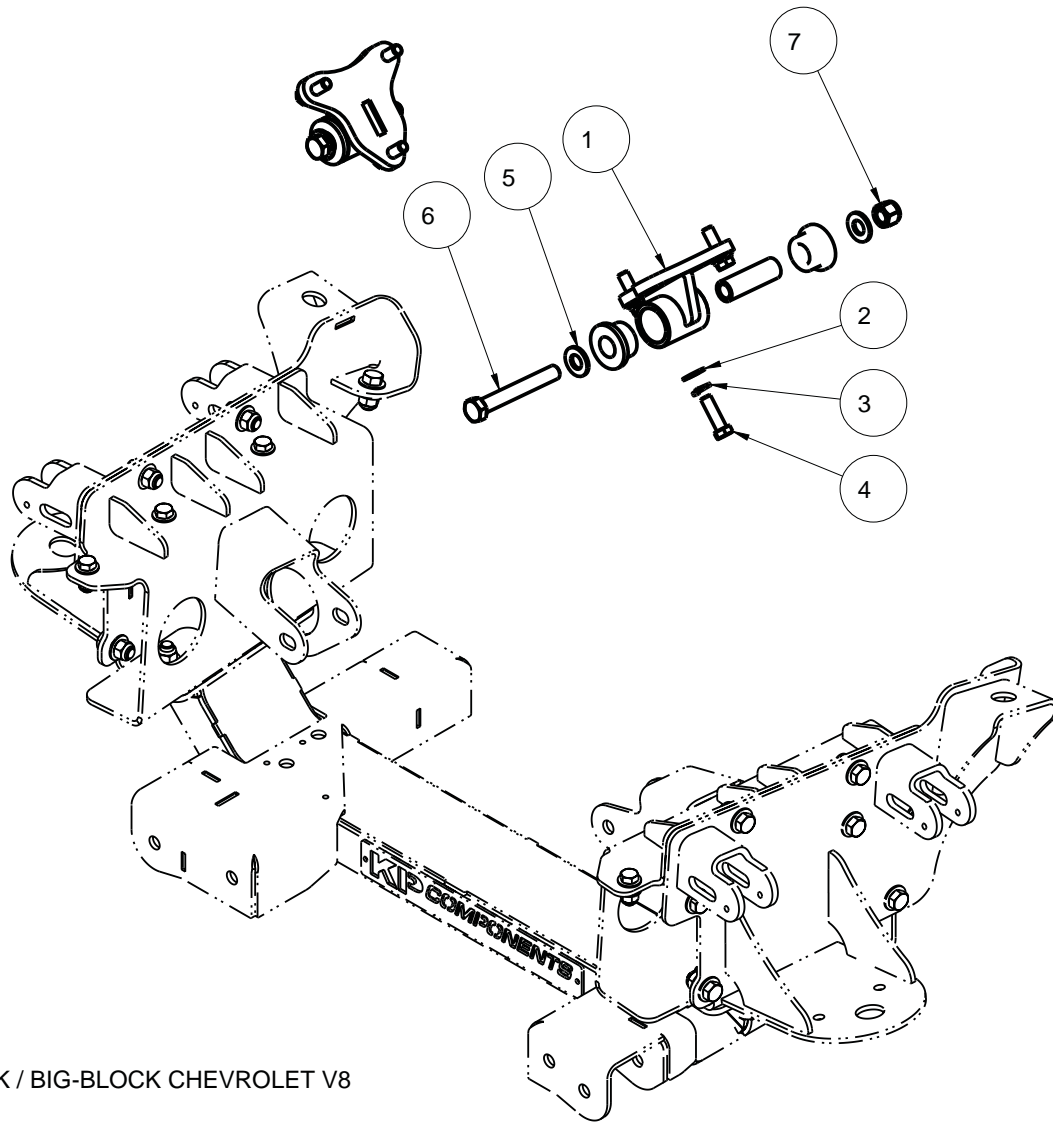

5917-CV8-S  
SMALL-BLOCK / BIG-BLOCK CHEVROLET V8

DESCRIPTION		DROPPED CROSSMEMBER, 1973-87 CHEVROLET/GMC C10	
Chris Alston's <b>CHASSISWORKS INC.</b> 8661 YOUNGER CREEK DRIVE SACRAMENTO, CA 95828 (916) 388-0288 FAX 388-0295		PART NO. <b>KPC FCB-C41</b>	
		1/30/20	DWG: KPC_FCB-C41

ITEM	QTY	PART NO.	DESCRIPTION
1	1	7901-077	FABRICATED MOTOR MOUNT ASSY, DRIVER, GM LS SERIES, NO OFFSET
2	1	7901-078	FABRICATED MOTOR MOUNT ASSY, PSGR, GM LS SERIES, NO OFFSET
3	8	3157-M10S-C	WASHER, M10 SAE, YELLOW ZINC, HV200, 10.5MM ID x 20MM OD x 2MM THICK
4	8	3108-M10R-C	LOCK WASHER, HELICAL SPRING M10, STEEL, ZINC
5	8	3146-10C-030-C	SOCKET HEAD CAP SCREW, M10-1.5 x 30MM, CLEAR ZINC
6	4	3120-050S-Y	FLAT WASHER, 1/2 SAE, HARDENED, YELLOW ZINC
7	2	3100-050C3.75Y	HEX BOLT, 1/2-13 x 3 3/4, GRADE 8, YELLOW ZINC
8	2	3101-050-13C	LOCKNUT 1/2-13, GRADE 5, NYLON INSERT, CLEAR ZINC

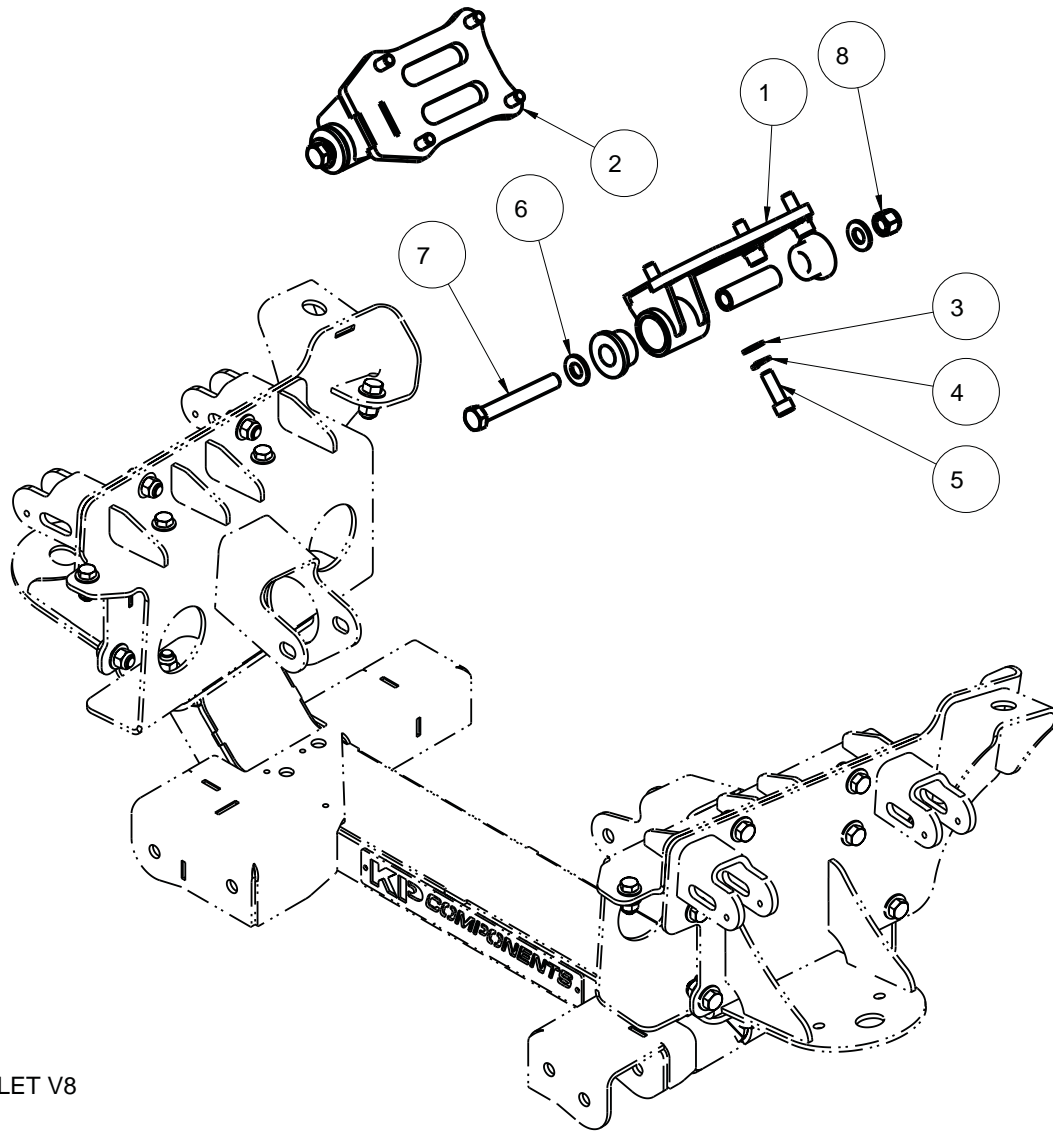

5917-LSR-S  
LSX CHEVROLET V8

DESCRIPTION		DROPPED CROSSMEMBER, 1973-87 CHEVROLET/GMC C10	
Chris Alston's CHASSISWORKS INC. 8661 YOUNGER CREEK DRIVE SACRAMENTO, CA 95828 (916) 388-0288 FAX 388-0295		PART NO. <b>KPC FCB-C41</b>	
		1/30/20	DWG: KPC_FCB-C41

# PARTS LIST

## 7925-FCBCXX.12 - Air-Bag Style Dropped Crossmember 1963-72 Chevy C10

1	7933-130	Dropped crossmember weldment
---	----------	------------------------------

## 7925-FCBC41.22 - Air-Bag Style Dropped Crossmember 1963-72 Chevy C10

1	7926-FCBC41	Hardware Bag
1	7933-164	Engine mount weldment, driver side
1	7933-165	Engine mount weldment, passenger side
1	7933-166	Arm and air-bag mount weldment, driver side
1	7933-167	Arm and air-bag mount weldment, passenger side

## 7926-FCBC41 - Hardware Bag

10	3100-038C1.00Y	Bolt 3/8-16 x 1" hex head, Grade 8, yellow zinc
16	3100-044C1.00Y	Bolt 7/16-14 x 1" hex head, Grade 8, yellow zinc
2	3100-044C1.25Y	Bolt 7/16-14 x 1-1/4" hex head, Grade 8, yellow zinc
4	3100-044C1.50Y	Bolt 7/16-14 x 1-1/2" hex head, Grade 8, yellow zinc
6	3101-038-16C	Locknut 3/8-16, nylon insert, clear zinc
20	3101-044-14C	Locknut 7/16-14, nylon insert, clear zinc
4	3108-038L-C	Lock washer 3/8" regular, clear zinc
2	3108-044L-C	Lock washer 7/16" regular, clear zinc
8	3120-044S-Y	Washer 7/16" hardened flat SAE, yellow zinc
16	3157-038S-C	Washer 3/8" flat SAE, clear zinc
34	3157-044S-C	Washer 7/16" flat SAE, clear zinc

## OPTION - Engine Mounts

1	5917-CV8-S	Chevrolet V8 small block and big block, steel (set)
1	5917-LSR-S	Chevrolet LS rear offset, steel (set)
1	KPC TCD-C31	Dropped transmission crossmember

## OPTION - Control Arms for 1963-70 Spindle

1	KPC BJL-C31	Lower ball joint, 1963-70 C10 (pair)
1	KPC BJU-C31	Upper ball joint, 1963-70 C10 (pair)
1	7925-LCAC31DCB	LayArm bag style lower control arms, 1960-87 C10 (set)
1	7925-UCAC31DC	LayArm upper control arms, 1960-87 C10 (set)

## OPTION - Control Arms for 1971-72 Spindle

1	KPC BJL-C41	Lower ball joint, 1971-87 C10 (pair)
1	KPC BJU-C41	Upper ball joint, 1971-72 C10 (pair)
1	7925-LCAC31DCB	LayArm bag style lower control arms, 1960-87 C10 (set)
1	7925-UCAC31DC	LayArm upper control arms, 1960-87 C10 (set)

### OPTION - Control Arms for 1973-87 Spindle

1	KPC B JL-C41	Lower ball joint, 1971-87 C10 (pair)
1	KPC B JU-C51	Upper ball joint , 1973-87 C10 (pair)
1	7925-LCAC31DCB	LayArm bag style lower control arms, 1960-87 C10 (set)
1	7925-UCAC31DC	LayArm upper control arms, 1960-87 C10 (set)

### OPTION - Air Bags

2	3470-SS7	Double-convoluted air bag, 7" diameter, single 1/2" NPT port
---	----------	--

### OPTION - Sway Bar

1	KPC ARFDCS-22	Front sway bar for dropped crossmember, 1-3/8" solid
---	---------------	--

### OPTION - Spindles

1	KPC DOS-C51-3	C10 2-1/2" drop spindle, 1.0" rotor thickness (requires '73-87 ball joints)
1	KPC DOS-C52-3	C10 2-1/2" drop spindle, 1.25" rotor thickness (requires '73-87 ball joints)
1	KPC DOS-C51-LUG	C10 2-1/2" drop spindle, KP 16" brake rotor (requires '73-87 ball joints)

### OPTION - Brakes

1	8368	KP 16" brake kit with red or black 6-piston calipers
1	MCG XXXXX	13" brake kit with iron caliper and 2-1/2" dropped spindle
		Options for 1963-87 C10, bolt circle, and drilled rotors

### OPTION - Shocks

1	KPC SANS-FDC	Non-adjustable steel body shocks (pair)
1	VAS 12042-515	Factory-valved billet-aluminum VariShock smooth-body (pair)
1	VAS 12142-515	Single-adjustable billet-aluminum VariShock smooth-body (pair)
1	VAS 12242-515	Double-adjustable billet-aluminum VariShock smooth-body (pair)
4	3153-38.85-45-B	Stem-mount bushing set for VariShock smooth-body

### OPTION - Steering

1	KPC RP-DC	Power rack and pinion
1	KPC RPM-DC	Power rack and pinion mounting kit
1	KPC TRE-C41	Tie-rod ends, tapered stud, 1971-87 C10 spindle
1	KPC TRE-U01	Tie-rod ends, 5/8" bolt, C10 spindle (may require drilling steering arm)

# INSTRUCTIONS

**IMAGES** - There are minor differences between C10 frames spanning 1960 to 1987. Images may have slight differences to your frame, however the installation procedure is identical.

**PRIOR TO INSTALLATION** - Remove the stock suspension crossmember by drilling out the rivets then clearing any debris that may interfere with installation.

**MODIFYING STOCK FRAME** - It may be necessary to trim or remove tabs or frame features to ensure the dropped crossmember mounts seat properly. Holes that do not align should be drilled out.

**ALIGNING THE BRACKETS** - The frame rail is very flexible and will likely require considerable force and prying to align the brackets when inserting hardware.

**LOOSELY INSTALL HARDWARE** - Other than the center crossmember bolts, do not tighten hardware until all five crossmember components are positioned.

1. The dropped crossmember and brackets align with the three holes along the bottom of the frame and one on the side of the frame at the lower rear corner.

A tapered drift punch, or two if available, will be very useful when aligning the bracket and frame holes.



2. Position the upper arm mount weldment against the outside of the frame. Align with the hole on the side of the frame using the drift punch, press tight against the bottom of the rail and clamp to hold in place.
3. The mounting hardware for the single hole on the side of the frame can be loosely installed at this time. *Refer to assembly diagram.*

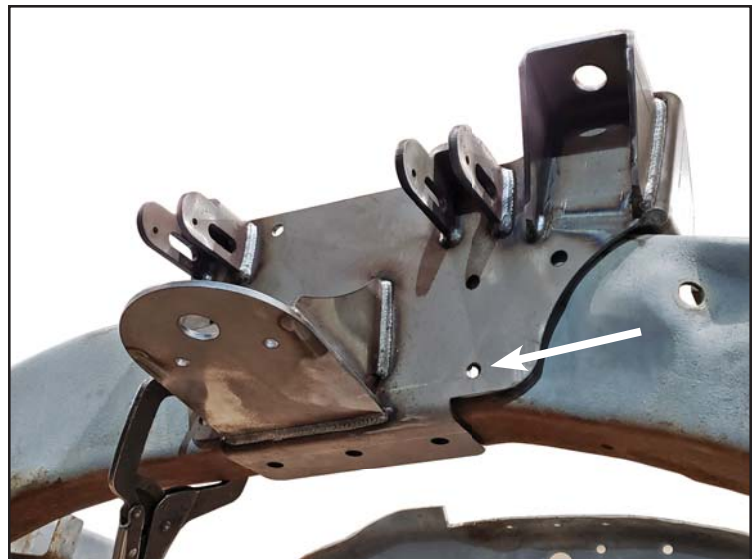

4. Raise the crossmember into position. If using a jack to raise the crossmember, only apply light pressure to hold as the components will need to be shifted to insert mounting hardware.



5. The drift punch should be used from underneath to maintain alignment while installing the center 7/16" bolt, lock washer and flat washer. Both driver and passenger sides of the crossmember must be aligned with the holes before tightening the center bolt to 40-50 lb-ft.
6. The engine mount weldment is position on inside of the frame rail. Again, use the drift punch to align the holes.
7. Loosely installation hardware into the two bottom holes at the crossmember. *Refer to assembly diagram.*

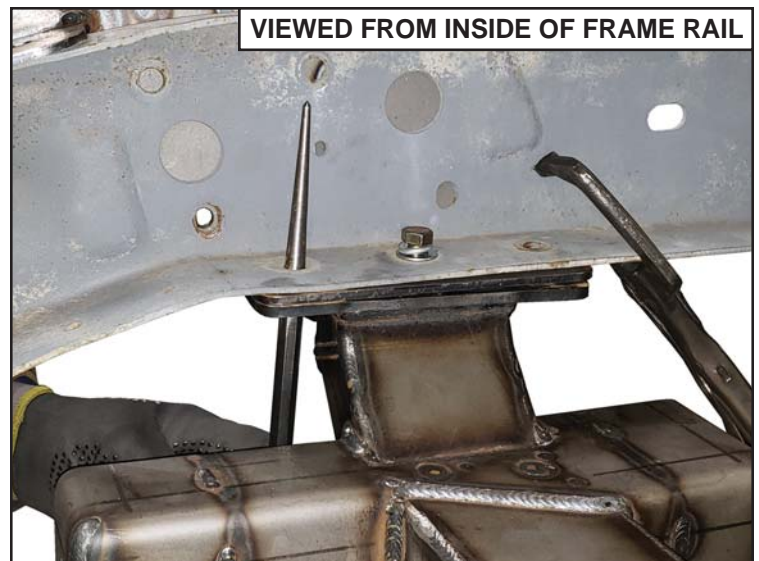

8. Depending on the condition of the stock frame, aligning the two remaining holes may take a little more effort. We recommend using two drift punches to align the holes, then vise-grip clamping the plates together to hold alignment.



9. Keep one of the drift punches engaged while installing the first of the two bolts. Tighten the first bolt before removing the drift punch and installing the second bolt.
10. At this point, all open holes should have loosely installed hardware. Alternately tighten hardware to remove free play and draw the brackets into place before fully tightening.
11. Use the newly installed brackets as a jig for drilling any remaining holes through the stock frame. All remaining hardware can be installed and fully tightened. *Refer to assembly diagram.*



## ENGINE POSITION AND OIL PAN

- Dropped crossmember relocates engine and requires the transmission tunnel be raised to accommodate transmission's new position.
- Chevrolet LS engine swaps require oil pans 302-1 or 302-2 from Holley Performance.
- Front offset LS engine mounts are available 5917-LSF-S (sold separately) to move the engine forward approximately 1-1/4".

## TRANSMISSION CROSSMEMBER

Installation of transmission crossmember (KPC TCD-C31) requires the engine and transmission be installed to correctly locate the crossmember position. With the crossmember and transmission mount bolted to the transmission, use the mount tabs as a guide to drill mounting holes into the frame.

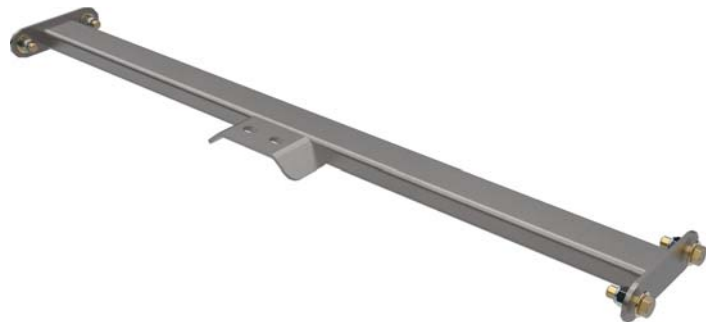

### WARRANTY NOTICE:

There are NO WARRANTIES, either expressed or implied. Neither the seller nor manufacturer will be liable for any loss, damage or injury, direct or indirect, arising from the use or inability to determine the appropriate use of any products. Before any attempt at installation, all drawings and/or instruction sheets should be completely reviewed to determine the suitability of the product for its intended use. In this connection, the user assumes all responsibility and risk. We reserve the right to change specification without notice. Further, Chris Alston's Chassisworks, Inc., makes **NO GUARANTEE** in reference to any specific class legality of any component. **ALL PRODUCTS ARE INTENDED FOR RACING AND OFF-ROAD USE AND MAY NOT BE LEGALLY USED ON THE HIGHWAY.** The products offered for sale are true race-car components and, in all cases, require some fabrication skill. **NO PRODUCT OR SERVICE IS DESIGNED OR INTENDED TO PREVENT INJURY OR DEATH.**

KP Components  
 A Chris Alston's Chassisworks Inc., Brand  
 8661 Younger Creek Drive  
 Sacramento, CA 95828  
 Technical Support: KPtech@cachassisworks.com

