

READ ALL INSTRUCTIONS COMPLETELY AND THOROUGHLY UNDERSTAND THEM BEFORE DOING ANYTHING.  
CALL TOTAL CONTROL PRODUCTS TECH SUPPORT (916) 388-0288 IF YOU NEED ASSISTANCE.

## INSTALLATION GUIDE



### 5905-X10 Center Support Driveshaft Loop 1962-67 Chevy II / Nova



**Description:** Bolt-on driveshaft loop, 2" wide x 1/4" thick x 5-1/2" diameter for center support

**Applications:** Chevy II / Nova 62-67

**Notes:** Installation of connector support required, modification to exhaust may be required

ITEM	QTY	PART NO.	DESCRIPTION
1	1	7959-0264	DRIVESHAFT LOOP BRACKET, G-BAR, 62-67 CHEVY II / NOVA
2	1	7959-0268	DRIVESHAFT LOOP WELDMENT, 5.00 OD x 2.00 WIDE x .250
3	8	3120-038S-Y	FLAT WASHER, 3/8 SAE, HARDENED, YELLOW ZINC
4	2	3100-038CI.25Y	HEX BOLT, 3/8-16 x 1 1/4, GRADE 8, YELLOW ZINC
5	4	3101-038-16C	LOCKNUT 3/8-16, GRADE 5, NYLON INSERT, CLEAR ZINC
6	2	3100-038CI.00Y	HEX BOLT, 3/8-16 x 1, GRADE 8, YELLOW ZINC

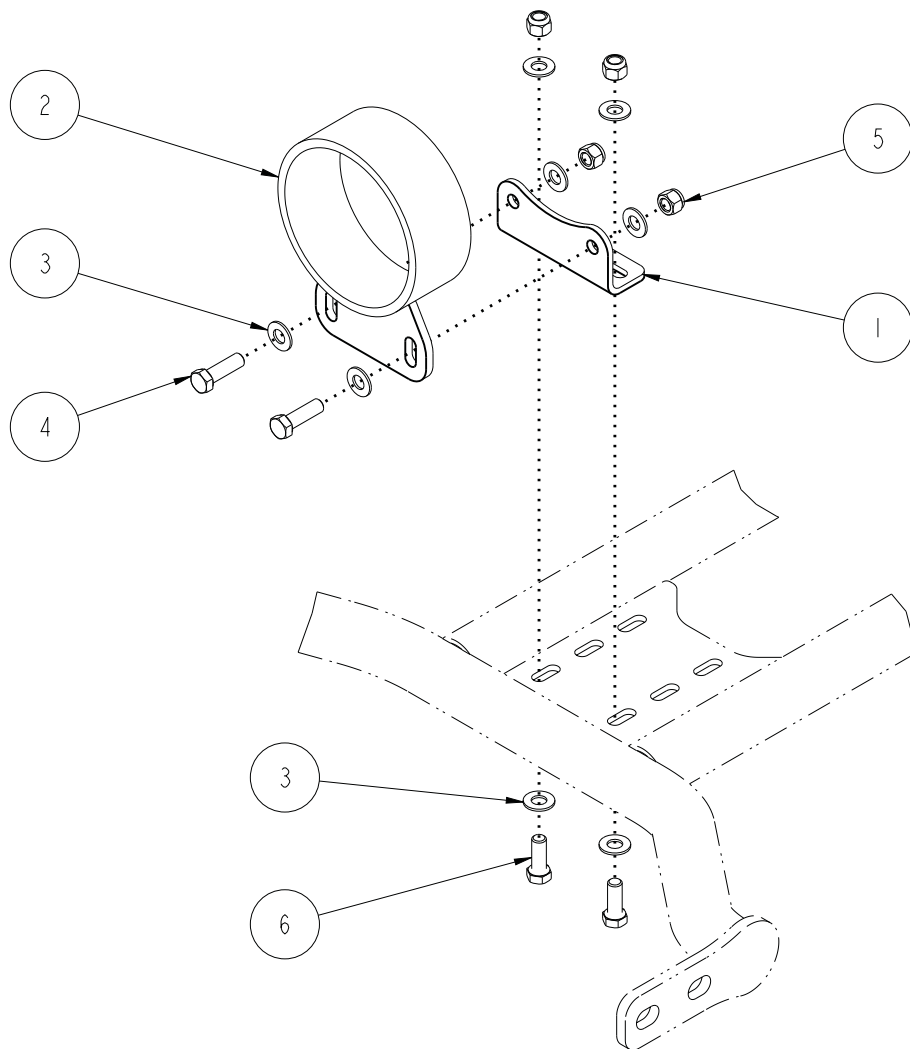

DESCRIPTION		<b>DRIVESHAFT LOOP, 62-67 CHEVY II / NOVA</b>	
<i>Chris Aston's</i> <b>CHASSISWORKS INC.</b> 8661 YOUNGER CREEK DRIVE SACRAMENTO, CA 95828 (916) 388-0288 FAX 388-0295		PART NO.	<b>5905-X10</b>
		2/23/15	DWG: 7951-5905X10

# PARTS LIST

## 5905-X10 - Center Support Driveshaft Loop 62-67 Chevy II / Nova

Qty	Part Number	Description
1	7959-0268	Driveshaft loop weldment
1	7952-5905X10	Hardware bag

### 7952-5905X10 - Hardware Bag

2	3100-038C1.00Y	Bolt 3/8-16 x 1" hex head cap screw
2	3100-038C1.25Y	Bolt 3/8-16 x 1-1/4" hex head cap screw
4	3101-038-16C	Locknut 3/8-16 nylon insert
8	3120-038S-Y	Washer 3/8 hardened flat SAE
1	7959-0264	Adjuster bracket

## INSTRUCTIONS

*NOTE: The following images were shot using a different vehicle platform and may show slight differences from the GM Chevy II platform. The installation procedure is identical.*

1. Raise vehicle by chassis into position with enough room to work underneath and so that rear suspension is at full extension.
2. Unbolt and remove driveshaft from vehicle.
3. The tail shaft of the transmission will need to be plugged to prevent fluid from draining.
4. Loosely bolt the adjuster bracket onto the drive shaft loop weldment.



5. Slide a flat washer over the 3/8-16 x 1-1/4" hex bolt and insert it through the bracket and weldment. Place a second flat washer on the bolt followed by the locknut.



6. Set the assembly on top of the center support as shown. The loop assembly should be positioned so the loop will be as close to the driveshaft front u-joint as possible.
7. Orientation of bracket and loop can be reversed to move driveshaft loop fore or aft.



8. Loosely bolt the loop assembly to the center support using the 3/8-16 x 1" hex bolts, flat washers and locknuts



9. Reinstall the driveshaft before proceeding.



10. Install the rear u-bolts and hand tighten them only at this point.



11. Most sanctioning bodies require the driveshaft loop be positioned within 6" of the front U-joint. Slide the loop assembly to get it within this dimension if possible.



12. Tighten the vertical bolts to 35 lb-ft.



13. Center the loop around the driveshaft and tighten the bolts to 35 lb-ft.



14. The drive shaft loop is installed.



15. You can now tighten the rear driveshaft U-bolts to the factory torque spec.



16. The installation for the complete subframe connector package is complete.



**WARRANTY NOTICE:**

There are NO WARRANTIES, either expressed or implied. Neither the seller nor manufacturer will be liable for any loss, damage or injury, direct or indirect, arising from the use or inability to determine the appropriate use of any products. Before any attempt at installation, all drawings and/or instruction sheets should be completely reviewed to determine the suitability of the product for its intended use. In this connection, the user assumes all responsibility and risk. We reserve the right to change specification without notice. Further, Chris Alston's Chassisworks, Inc., makes **NO GUARANTEE** in reference to any specific class legality of any component. **ALL PRODUCTS ARE INTENDED FOR RACING AND OFF-ROAD USE AND MAY NOT BE LEGALLY USED ON THE HIGHWAY.** The products offered for sale are true race-car components and, in all cases, require some fabrication skill. **NO PRODUCT OR SERVICE IS DESIGNED OR INTENDED TO PREVENT INJURY OR DEATH.**

Chris Alston's Chassisworks  
8661 Younger Creek Drive  
Sacramento, CA 95828  
Phone: 916-388-0288  
Technical Support: [sales@cachassisworks.com](mailto:sales@cachassisworks.com)

