

READ ALL INSTRUCTIONS COMPLETELY AND THOROUGHLY UNDERSTAND THEM BEFORE DOING ANYTHING.
CALL CHASSISWORKS TECH SUPPORT (916) 388-0288 IF YOU NEED ASSISTANCE.

INSTALLATION GUIDE



7136-HD 3x2 Eliminator II Rear Frame



Description: 3x2 frame kit, universal fit. designed for Eliminator II 4-link

Includes: Frame rails, front crossmember, driveshaft oval, shock crossmember, and rear crossmember

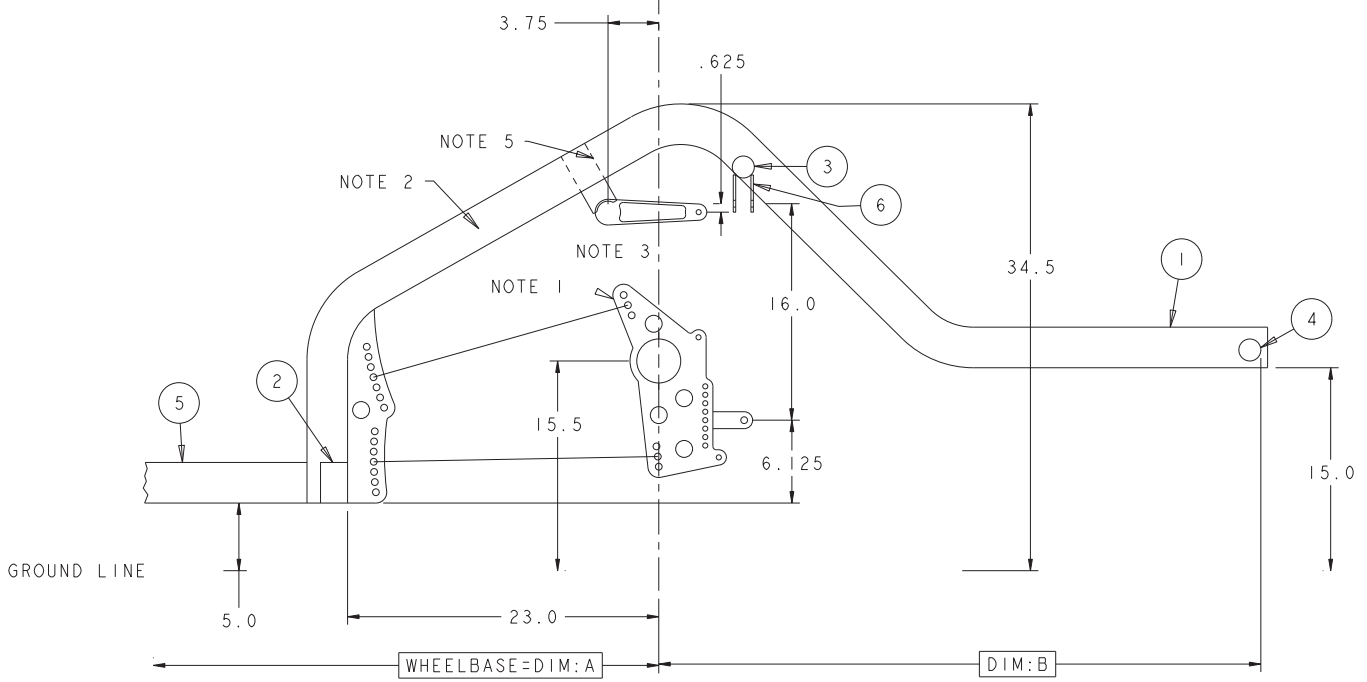
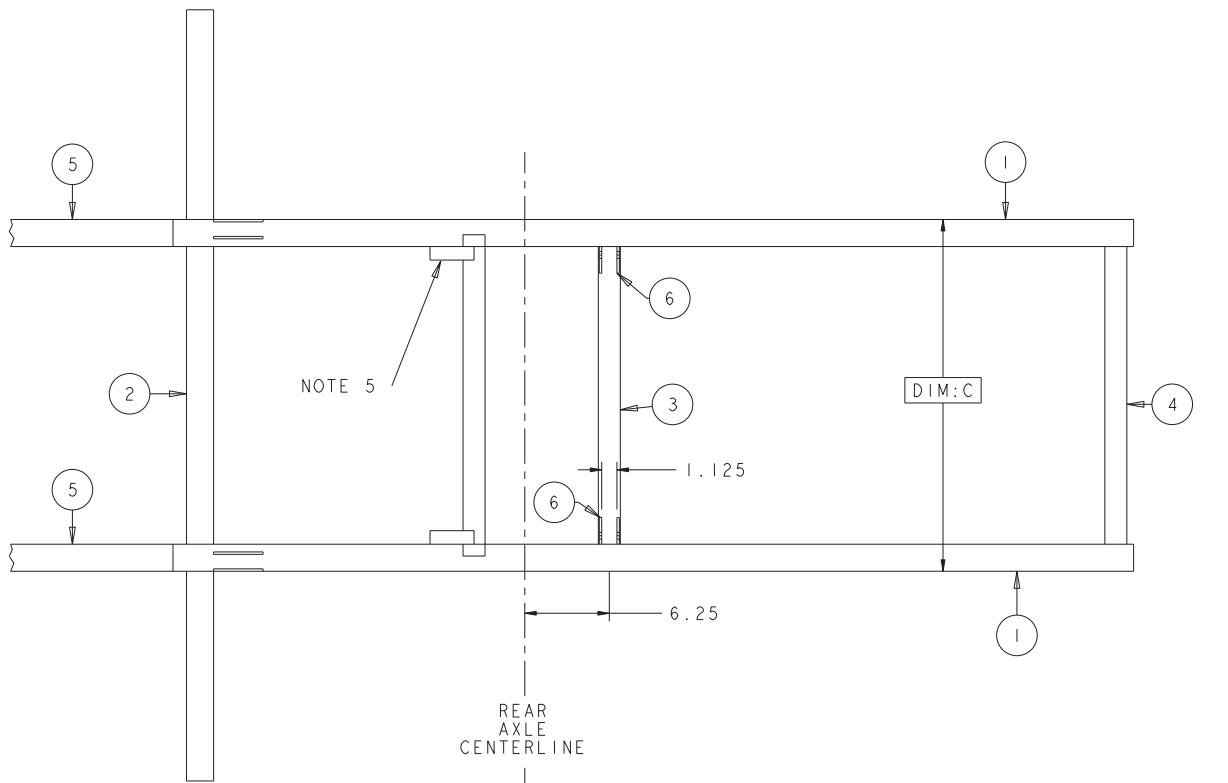

7136 ELIMINATOR II 3x2 REAR FRAME CLIP

CHRIS ALSTON'S CHASSISWORKS INC
8661 YOUNGER CREEK DRIVE
SACRAMENTO, CA 95828

03/10/97

DO NOT SCALE DRAWING

SEE THE INSTRUCTION
SHEET FOR THE ITEM
NUMBER DESCRIPTIONS

- NOTE 1:
ADJUSTABLE HEIGHT SHOCK MOUNTS AND 4 LINK MUST BE PURCHASED SEPARATELY.
NOTE 2:
ALL CHASSIS TO GROUND HEIGHT DIMENSIONS ARE FIGURED WITH A 33" DIAMETER
REAR TIRE.
NOTE 3:
ANTI ROLL BAR ARM SHOWN, PURCHASE SEPARATELY NO. 6266
NOTE 4:
POSITION DRIVESHAFT LOOP TO HAVE THE SAME OFFSET IN FRAME AS DRIVESHAFT
NOTE 5:
ANTI ROLL BAR MOUNT SHOWN, PURCHASE SEPARATELY NO. 6202

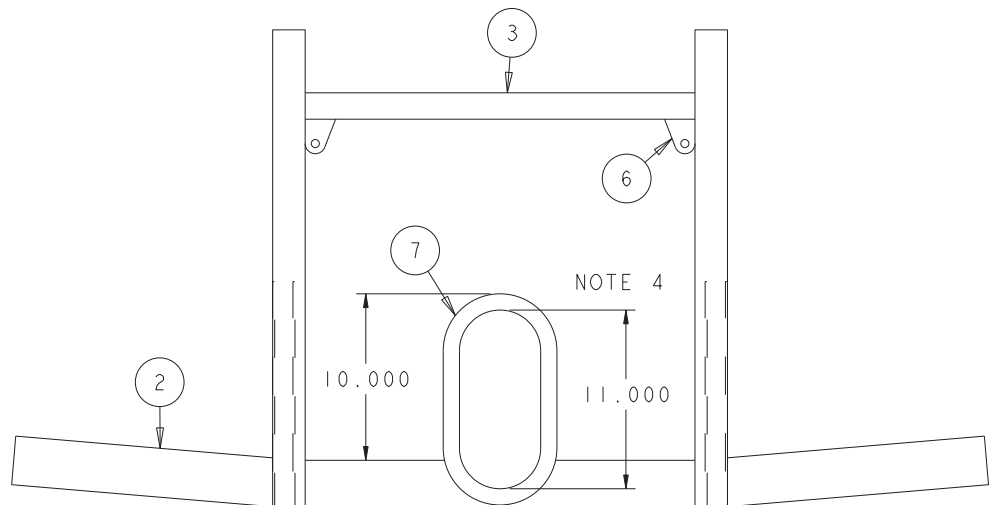

PARTS LIST

Prior to beginning installation use the following parts lists to verify that you have received all components required for installation.

7136-HD - Eliminator II 3x2 Rear Frame Kit

Qty	Part Number	Description
1	4428	Straight-tube box for Eliminator II 4-link rear frame
2	4516	Tubing bend, 180-degrees, 2 x 1 x 11" tall
1	4525	Rear frame rail, Eliminator II 4-link (pair)

4428 - Straight-Tube Box for Eliminator II 4-Link Rear Frame

Qty	Part Number	Description
1	4526	Crossmember 3 x 2 x 60" long, 1-1/2" drop
1	E26.134-030.000	Shock crossmember tube, 1 5/8" x .134 ERW x 30"
1	E26.134-030.000	Rear crossmember tube, 1 5/8" x .134 ERW x 30"
2	B3224.120-54.00	Tube 3 x 2 x .120" ERW 54" (Subframe connectors)
1	904428	Hardware bag

904428 - Hardware Bag

Qty	Part Number	Description
4	2125	Frame tab 1/2" hole

OPTIONS - Floor and Tubs (Steel)

Qty	Part Number	Description
1	6602	Steel wheel tubs, 24" x 40"
1	6614	Steel wheel tubs, 28" x 43"
1	6616	Steel floor kit

OPTIONS - Floor and Tubs (Aluminum)

Qty	Part Number	Description
1	6603	Aluminum wheel tubs, 24" x 40"
1	6608	Aluminum wheel tubs, 28" x 43"
1	6615	Aluminum floor kit

INSTRUCTIONS

NOTE: Please read all instructions before you begin. This kit is designed to provide a rear subframe for use with coil over shocks and an Eliminator II 4-link. It should be used with at least a 10 point roll cage with the "X" brace. This rear frame kit is easily installed by cutting out the entire floor from the dropped crossmember to the taillight panel. This will require that the floor be replaced with aluminum or steel panels. You can use our Eliminator II Rear Floor Kit, Part No. 6615 in aluminum or, Part No. 6616 in steel.

1. Measure 25 inches forward from the rear axle centerline to a point on the rocker panel. Draw a line between these points on the car's floor. This is sometimes easier to do under the car because of the driveshaft tunnel. Cut the entire floor and wheel wells out of the car from your line to the rear taillight panel. Cut out the package tray and double panels against the sides of the car leaving the inner part of the rocker panel in place. In most cases, you will have to remove most of the rear window crank mechanism to make room for the new wheel wells. Usually a simple bracket welded to the body and bolted to the window will hold the windows up. When you are cutting out the stock driveshaft tunnel, leave it approximately 2 inches longer than the frame crossmember. This will allow for a neater installation of the aluminum.
2. Install the dropped crossmember first. After you have cut the floor out and neatly trimmed all the panels, you must level the car front to rear and right to left. The door sills are a good place to put your level. When you cut the floor out, you should have left the inner part of the rocker panel in place. The rocker panel should be trimmed to allow for a good fit of the dropped crossmember. Center the crossmember between the rocker panels. If your inner rocker panel is not straight, you will have to contour the ends of the cross-member. Make sure you have a good fit to the rocker panel or it will be difficult to weld. Hold the crossmember in place so the forward side is 25 inches forward of the rear axle centerline. The bottom should be even with the bottom of the rocker panel.
3. Mark the center of the driveshaft tunnel on the crossmember. The tunnel will usually be offset from the center of the car to the passenger side about 1/2 inch. This is because most cars have an offset engine. Measure your stock rear end to determine the amount of offset. Once you have it marked, take the crossmember out of the car.
4. Using the two U-bends, make a driveshaft loop. Place the two U-bends open end to open end, and trim them so the overall height is 13 inches. Weld them together.
5. Place the driveshaft loop on the crossmember and center it on the driveline centerline we marked. Place it 1/8 of an inch up from the bottom of the crossmember, trace around it. Cut the crossmember out and weld the driveshaft loop in the cut out. Be sure it is square and flat when installed.
6. Position the dropped crossmember between the rocker panels in the spot we previously marked and tack weld in place.
7. The rear frame needs to be trimmed at each end to fit in the car. To cut the front to the correct length, measure 26 1/2 inches straight down from the top of the bend over the rear end and cut off the excess (see the assembly drawing). Measure from the back of the crossmember to the taillight panel. Cut the frame rails to this length and tack them in place. In cars with a rear frame crossmember that holds the bumper on, it is a good idea to attach the stock crossmember to the new subframe. Retain the stock crossmember to mount the bumper and rear of the body to. The frame rails should be centered in the car an equal distance from the car's centerline. They should be a minimum of 20 inches wide on the outside. Make the frame as wide as possible while leaving enough room for the tire. Make sure the rails are centered on the taillight panel and on the crossmember. They should both be an equal distance from each side of the car and at the same height. The rear of the rail (the part in the trunk) should be level to the rocker panel plus or minus 5 degrees.

8. Install the crossmembers. The rear crossmember (item #4) should be a 1/2 inch from the bottom of the frame and approximately 1/2 inch forward of the taillight panel. Weld the frame tabs to the shock crossmember (item #3) even with the ends. Be sure all 4 brackets are in the same plane. The bracket spacing when using Koni shocks is 1 1/8 inches. The piece of tubing works good to make a spacer. Put the crossmember between the frame rails at the dimensions shown. All measurements are to the center of the shock mount tabs.
9. Install the chassis 4-link mount. The 4-link mount attaches to the back side of the frame and crossmember with the brackets even with the outside edge of the frame. Use a rod end to get the correct spacing between them. The brackets must be straight or the 4-link will not fit right. After you have double checked all dimensions, finish welding the frame in. The front brackets are part of the 4-link kit, Part No. 6292. Also, you will need to use an Eliminator II Adjustable Lower Shock Mount, Part No. 6247.
10. Install the subframe connectors (in full frame cars like '55-'57 Chevys, Chevelles, etc., the connectors are not necessary because the frame welds to the dropped cross-member). They run from the dropped crossmember forward to the stock front subframe. The floor will have to be slotted for the connectors. In most cases, the connector will be wider spaced at the front than at the dropped crossmember, where it should be the same width as the new rear frame.
11. If you are using a tire with a diameter smaller than 33 inches, raise the adjustable shock mount on its axle bracket to raise the rear of the car.
12. If you purchased the frame clip welded, the dropped crossmember and the rear frame length will be too long. Cut them to length for your application. The rear frame crossmember is tacked between the rails for shipping purposes. Knock it out and reinstall it at the correct position after you have trimmed the rear rails to length.
13. The antiroll bar mounts (part no. 6202) are used to mount the Antiroll Bar, Part No. 6266. The drawing shows the position of the antiroll bar in relation to the shock mounts and springs. The aluminum billet arms need to be the same width as the frame rail and should be level when the car is at ride height. See the instructions provided with the Part Nos. 6266 and 6202 for more details.

NOTES:

WARRANTY NOTICE:

There are NO WARRANTIES, either expressed or implied. Neither the seller nor manufacturer will be liable for any loss, damage or injury, direct or indirect, arising from the use or inability to determine the appropriate use of any products. Before any attempt at installation, all drawings and/or instruction sheets should be completely reviewed to determine the suitability of the product for its intended use. In this connection, the user assumes all responsibility and risk. We reserve the right to change specification without notice. Further, Chris Alston's Chassisworks, Inc., makes **NO GUARANTEE** in reference to any specific class legality of any component. **ALL PRODUCTS ARE INTENDED FOR RACING AND OFF-ROAD USE AND MAY NOT BE LEGALLY USED ON THE HIGHWAY.** The products offered for sale are true race-car components and, in all cases, require some fabrication skill. **NO PRODUCT OR SERVICE IS DESIGNED OR INTENDED TO PREVENT INJURY OR DEATH.**

Chris Alston's Chassisworks
8661 Younger Creek Drive
Sacramento, CA 95828
Phone: 916-388-0288
Technical Support: tech@cachassisworks.com

