

INSTALLATION GUIDE



6153 g-Machine Lower A-Arms



Description: Lower g-Machine A-arms, matte flat black with balljoints and stainless pivot pins for Street Machine crossmember

Notes:

1. Installation requires use of Street Machine crossmember and spindle.
2. The assembly drawing (page 2) shows components for 6153 (Items 1-5) and 6154 (Items 6-15).

ITEM	QTY	PART NO.	DESCRIPTION
1	1	5060	G-MACHINE LOWER A-ARM DRIVERS, MILD STEEL, PLAIN
2	1	3304	FA395 BALL JOINT CHRYSLER SCREW IN
3	4	3333	PLASTIC BUSHING
4	2	1652	PIVOT STUD STAINLESS STEEL .75 X 2.50 X 5/8-18 THREAD
5	2	3106-31C00.38S	OVAL POINT SET SCREW, 5/16-18 x 3/8, STAINLESS
6	2	3140-1216-08	SLEEVE, $\varnothing 1/2$ x .384 x 1/4
7	3	3109-038-S-2-Y	AIRCRAFT WASHER, 3/8 x .062 THICK
8	1	3128	HEX BOLT, 3/8-24 x 2, GRADE 8, YELLOW ZINC
9	1	3101-038-24C	LOCKNUT, 3/8-24, GRADE 8, NYLON INSERT, CLEAR ZINC
10	1	3127-038X038-RT	ROD END 3/8 x 3/8 BORE RT MALE, CF6
11	1	3111-038X038-RT	ROD END 3/8 x 3/8 BORE 4130 RT MALE, CM6
12	1	3102-038-24RC	JAM NUT, 3/8-24 RIGHT, CLEAR ZINC
13	1	3108-038L-C	LOCKWASHER, 3/8 MEDIUM, PLATED
14	1	3103-038F1.25C	SOCKET HEAD CAP SCREW, GRADE 8, 3/8-24 x 1 1/4, CLEAR ZINC
15	1	5050-24	1" FRONT SWAY BAR ASSEMBLY, G/M A-ARM, 24" CROSSMEMBER

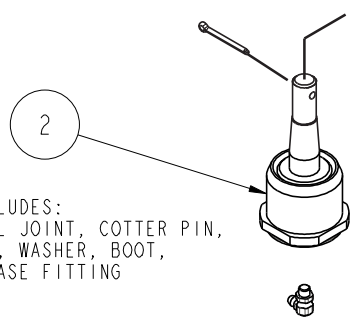
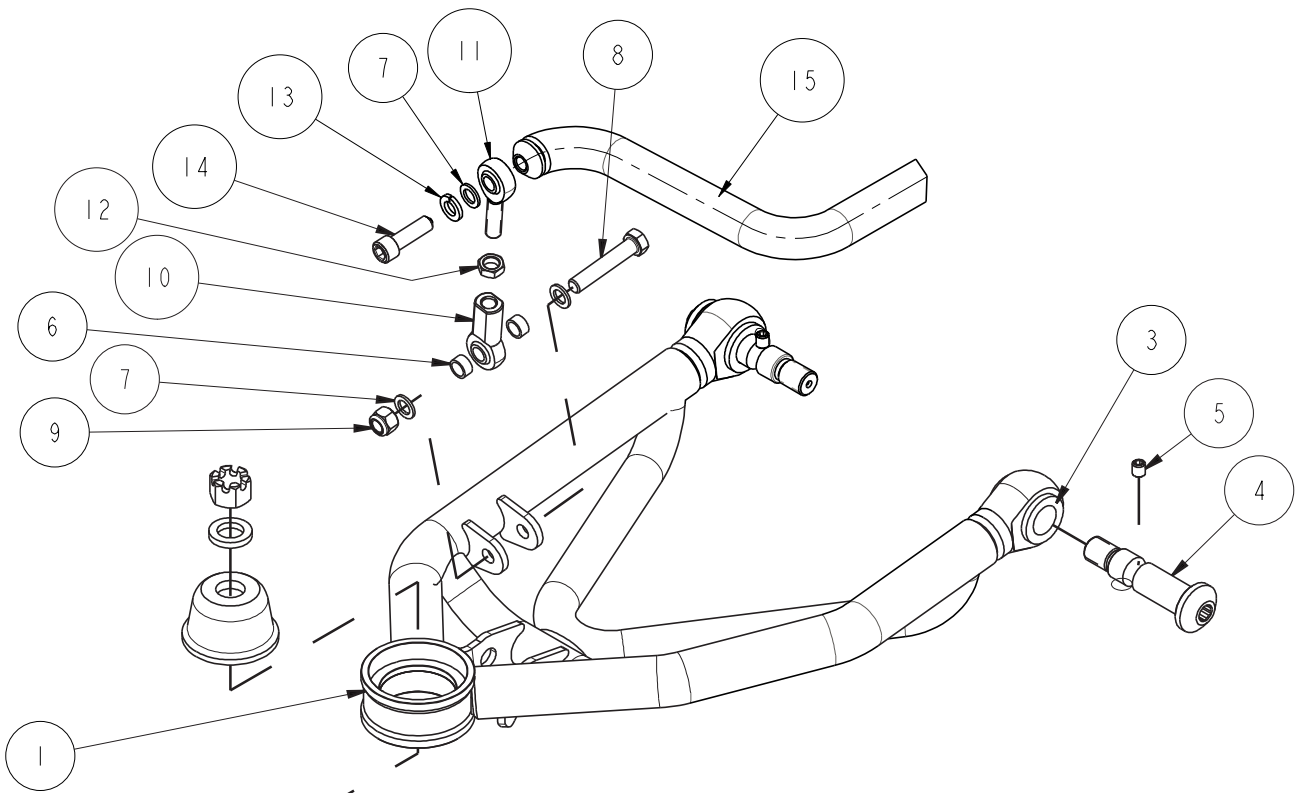

INCLUDES:
BALL JOINT, COTTER PIN,
NUT, WASHER, BOOT,
GREASE FITTING

TABLE QUANTITIES REPRESENT DRIVER SIDE ONLY.

DESCRIPTION		G-MACHINE LOWER A-ARM ASSEMBLY, BLACK	
Chris Alston's CHASSISWORKS INC. 8661 YOUNGER CREEK DRIVE SACRAMENTO, CA 95828 (916) 388-0288 FAX 388-0295		PART NO.	6153 & 6154
		2/8/07	DWG: 916153

PARTS LIST

Qty	Part Number	Description
2	3304	Balljoint, Screw-In
8	3333	Flanged Bearing, 3/4 ID x 1" OD
1	5060-2	g-Machine Lower A-arm, Driver Side, Black
1	5061-2	g-Machine Lower A-arm, Passenger Side, Black

906153 - Hardware Bag Components

Qty	Part Number	Description
4	1652	Pivot Stud, Stainless Steel, 3/4 x 2-1/2 x 5/8-18
4	3106-31CO0.38S	Set Screw, Oval Point, Stainless Steel, 5/16-18 x 3/8

INSTRUCTIONS

Prior to beginning installation, use the parts list to verify that you have received all components required for installation.

1. Insert one self-lubricating pivot bushing (Item 3) into each side of the weld eyes until the flange bottoms out.
2. Before installing the lower A-arms, the frame mount threads must be chased. Use a 5/8-18 RH tap to chase threads on the front and backsides of both lower A-arm mounts. Clear any debris left in the threads with an air hose.
3. Apply anti-seize onto threads of pivot studs (Item 8) and A-arm mounts. Test fit each pivot stud in the mounting hole it will use. Studs should screw in easily until they bottom out.

NOTE: Always use anti-seize when working with stainless steel hardware. Failing to do so will cause damage to the threads. If the stud begins to tighten or seize before fully seated DO NOT use heavy force. Clean both male and female threads with a tap and die, apply anti-seize, then carefully assemble.

4. DO NOT grease the pivot bushings.
5. Position the A-arm at it's correct mount and insert the pivot studs by hand. If the bushing fit is too tight to press in by hand, a T-handle or regular Allen wrench can be used to apply pressure while turning the stud. Be careful not to damage the threads.

NOTE: The letter "D" or "P" on the balljoint housing identifies which side of the car the A-arm installs in.

6. Once pivot studs are in place, use an Allen T-wrench to tighten them until they are fully seated. This will give the bushings the proper amount of crush. Check to be sure the A-arm swings freely throughout it's travel but with a small amount of resistance.
7. Apply a drop of Loctite™ onto threads of oval-point set screw (Item 5), then screw into A-arm mount to lock the pivot stud. Be careful not to get excess Loctite™ in the pivot stud bore.
8. Repeat the installation of the lower A-arm on the passenger side.
9. Suspension adjustment of caster and camber alignment is done with the upper A-arms.

WARRANTY NOTICE:

There are NO WARRANTIES, either expressed or implied. Neither the seller nor manufacturer will be liable for any loss, damage or injury, direct or indirect, arising from the use or inability to determine the appropriate use of any products. Before any attempt at installation, all drawings and/or instruction sheets should be completely reviewed to determine the suitability of the product for its intended use. In this connection, the user assumes all responsibility and risk. We reserve the right to change specification without notice. Further, Chris Alston's Chassisworks, Inc., makes **NO GUARANTEE** in reference to any specific class legality of any component. **ALL PRODUCTS ARE INTENDED FOR RACING AND OFF-ROAD USE AND MAY NOT BE LEGALLY USED ON THE HIGHWAY.** The products offered for sale are true race-car components and, in all cases, require some fabrication skill. **NO PRODUCT OR SERVICE IS DESIGNED OR INTENDED TO PREVENT INJURY OR DEATH.**

Chris Alston's Chassisworks
8661 Younger Creek Drive
Sacramento, CA 95828
Phone: 916-388-0288
Technical Support: tech@cachassisworks.com

