

READ ALL INSTRUCTIONS COMPLETELY AND THOROUGHLY UNDERSTAND THEM BEFORE DOING ANYTHING.  
CALL CHASSISWORKS TECH SUPPORT (916) 388-0288 IF YOU NEED ASSISTANCE.

## INSTALLATION GUIDE

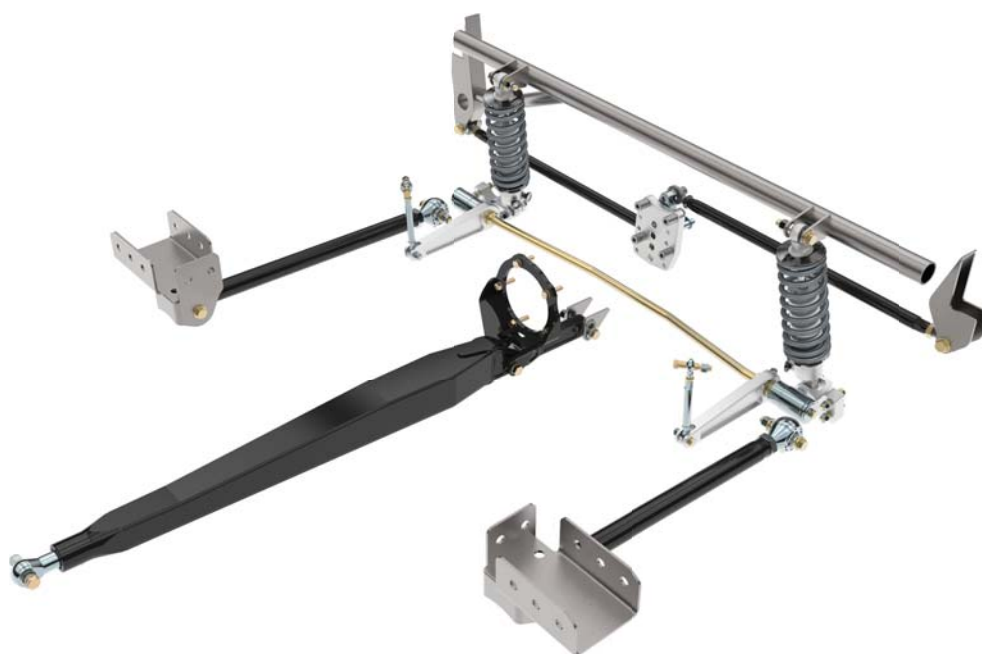

### 5857-X10-02 g-Link Torque Arm Coil-Over Suspension 1962-1967 Nova (Chevy II)



**Description:** Torque arm rear coil-over suspension for 1962-1967 Nova (Chevy II).

**Includes:** Torque arm, Watts link, pivot-ball lower links, shocks, crossmember, frame, axle brackets.

**Options:** Splined-end anti-roll bar, coil-over or air-spring shocks, shock valving, coil-spring rate, torque-arm-bracket weld fixture, tubular or billet lower links, front torque-arm crossmember, pivot-ball or poly-bushing torque-arm slider pivot, Strange Pro-Aluminum mount.

**Notes:** Installation requires welding. Not for use with 10- or 12-bolt Chevrolet housings. Requires Ford 9" or direct-fit FAB9™ housing.

- SPECIAL ORDER PART NOT RETURNABLE FOR ANY REASON -



ITEM QTY	PART NO.	DESCRIPTION
1	7959-2002	TORQUE ARM MOUNT, G-STREET PINION SUPPORT, STRANGE ST IRON
2	7959-0280	TORQUE ARM WELDMENT, 70-73 CAMARO
3	899-016-1.125-W	WIPER, 1 1/8 PISTON ROD, HALLITE 8880710
4	7959-0175	SLIDING LINK ASSY, TORQUE ARM, 1.10 BALL PIVOT
5	7959-0287	ADJUSTER, TORQUE ARM, 7/8-14 THREAD
6	7959-0288	WASHER, SERRATED, □ 1/2
7	3109-050-S-2-Y	AIRCRAFT WASHER 1/2 x .062 THICK
8	3100-050F3.75Y	HEX BOLT, 1/2-20 x 3 3/4, GRADE 8, YELLOW ZINC
9	3101-050-20C	LOCNUT, 1/2-20, GRADE 5, NYLON INSERT, CLEAR ZINC
10	3100-050F3.25Y	HEX BOLT, 1/2-20 x 3 1/4, GRADE 8, YELLOW ZINC
11	3109-038-S-2-Y	AIRCRAFT WASHER 3/8 x .062 THICK
12	3100-038C1.50Y	HEX BOLT, 3/8-16 x 1 1/2, GRADE 8, YELLOW ZINC
13	3100-050F2.50Y	HEX BOLT, 1/2-20 x 2 1/2, GRADE 8, YELLOW ZINC
14	3144-25-28-0	GREASE ZERK 1/4-28 STRAIGHT
15	E26.134-036.000	STEEL TUBE □ 1/2 x 36
16	7959-0328	PIVOT BRACKET, TORQUE ARM, 3 HOLE
17	7959-0329	GUSSET, PIVOT BRACKET, TORQUE ARM, 3 HOLE
18	7959-0184	TUBE CONNECTOR FLANGE, 1 5/8 MILD STEEL
19	E20.120-036.000	STEEL TUBE, □ 1/2 x 1/4 x .120 ERW x 36.000 LONG
20	3109-038-S-2-Y	AIRCRAFT WASHER 3/8 x .062 THICK
21	3100-038C1.00Y	HEX BOLT, 3/8-16 x 1, GRADE 8, YELLOW ZINC
22	3101-038-16C	LOCNUT 3/8-16, GRADE 5, NYLON INSERT, CLEAR ZINC
23	7959-2012	MOUNTING PLATE, WATTS LINK, 4 POSITION ADJUSTABLE, FAB-9
24	7959-2014	SPACER, □ 7/8 OD x .120 WALL x .313 LONG
25	7959-2026	BEL. CRANK ASSEMBLY, WATTS LINK, G-STREET
26	7959-2015	SPACER, □ 5/8 OD x .120 WALL x 1.625 LONG
27	7959-2016	TOP PLATE, G-STREET WATTS LINK
28	7959-2017	STANDOFF, G-STREET WATTS LINK
29	3108-063L-C	LOCK WASHER □ 5/8, SPRING
30	3103-063C2.50B	SOCKET HEAD CAP SCREW, 5/8-11 x 2 1/2, BLACK OXIDE
31	3108-038L-C	LOCK WASHER, HELICAL SPRING □ 3/8, STEEL, ZINC
32	3103-038C2.50C	SOCKET HEAD CAP SCREW, GRADE 8, 3/8-16 x 2 1/2, CLEAR ZINC
33	3136-063XC50-RT	ROD END, 5/8-8 RIGHT x 1/2 BORE CMX10-8T-FI
34	3157-050S-C	WASHER, 1/2 SAE, ZINC PLATED, 1/2 ID x 1 1/16 OD x 3/32 TH
35	3108-050L-C	LOCKWASHER, 1/2 MEDIUM, PLATED
36	3103-050C1.75B	SOCKET HEAD CAP SCREW, 1/2-13 x 1 3/4, BLACK OXIDE
37	3102-063-18RC	JAM NUT, 5/8-18 RIGHT, CLEAR ZINC
38	1136	TUBE ADAPTER .830 x 5/8-18 RIGHT
39	A16.083-020.000	CUT TUBE, 20.000 x □ 1 x .083 WALL 4130
40	1506	TUBE ADAPTER .830 x 5/8-18 LEFT
41	3102-063-18LY	JAM NUT, 5/8-18 LEFT, YELLOW ZINC
42	3136-063XC50-LT	ROD END, 5/8-8 LEFT x 1/2 BORE CMX10-8T-FI
43	3108-038-S	HIGH COLLAR LOCKWASHER, 3/8 STAINLESS
44	3103-038C1.00C	SOCKET HEAD CAP SCREW, GRADE 8, 3/8-16 x 1, CLEAR ZINC,
45	1000	MISALIGNMENT BUSHING □ 1/2 BORE x .250

46	2	7959-2018	FRAME BRACKET, DRIVER FRONT, FI G-STREET WATTS LINK
47	2	7959-2020	FRAME BRACKET, PSGR FRONT, FI G-STREET WATTS LINK
48	1	7959-2022	GUSSET, WATTS LINK FRAME BRACKET, DRIVER, FI G-STREET
49	1	7959-2024	GUSSET, WATTS LINK FRAME BRACKET, PASSENGER, FI G-STREET
50	1	D26.125-061.500	CUT TUBE, □ 1/2 x 5/8 x .125 WALL DOM x 1.500
51	4	3120-050S-Y	FLAT WASHER, 1/2 SAE, HARDENED, YELLOW ZINC
52	2	3100-050F2.50Y	HEX BOLT, 1/2-20 x 2 1/2, GRADE 8, YELLOW ZINC
53	2	3101-050-20C	LOCNUT, 1/2-20, GRADE 5, NYLON INSERT, CLEAR ZINC
54	1	E26.134-048.000	STEEL TUBE, Ø 1 5/8 x .134 ERW x 48.000 LONG
55	4	2101	SUSPENSION TAB 1/2 INCH HOLE
56	1	7959-2025	CROSS TUBE, G-STREET WATTS LINK, FI
57	12	3120-050S-Y	FLAT WASHER, 1/2 SAE, HARDENED, YELLOW ZINC
58	4	3100-050F2.75Y	HEX BOLT, 1/2-20 x 2 3/4, GRADE 8, YELLOW ZINC
59	4	3101-050-20C	LOCKNUT, 1/2-20, GRADE 5, NYLON INSERT, CLEAR ZINC
60	8	7955-093-125	SPACER, □ 1/2 BORE x .125 LONG, □ 1/2 .85 OD x .175 OAL
61	2	3813-24.00-AD	LOWER LINK ASSEMBLY, G-LINK, 3.085 PIVOT BALL, 24 CENTER
62	2	3100-050C3.50Y	HEX BOLT, 1/2-13 x 3 1/2, GRADE 8, YELLOW ZINC
63	4	3101-050-13C	LOCNUT 1/2-13, GRADE 5, NYLON INSERT, CLEAR ZINC
64	2	3100-050C5.00Y	HEX BOLT, 1/2-13 x 5, GRADE 8, YELLOW ZINC
65	1	1477-D	G-BAR STRAIGHT SHOCK MOUNT, DRIVER, ADJUSTABLE, OFFSET
66	8	3109-038-S-2-Y	AIRCRAFT WASHER 3/8 x .062 THICK
67	4	3100-038F2.00Y	HEX BOLT, 3/8-24 x 2, GRADE 8, YELLOW ZINC
68	4	3101-038-24C	LOCNUT, 3/8-24, GRADE 5, NYLON INSERT, CLEAR ZINC
69	2	VAS 11211-425	C/O Q2, COM8 x COM8, 5.15 TRAVEL
70	1	1477-P	G-BAR STRAIGHT SHOCK MOUNT, PSGR, ADJUSTABLE, OFFSET
71	1	7959-0245	LCA BRACKET, CHASSIS, DRIVER, MINI-TUB G-BAR, 62-67 CHEVY II /
72	1	7959-0248	LCA BRACKET, CHASSIS, PASSENGER, MINI-TUB G-BAR, 62-67 CHEVY II
73	1	7959-0115	ANTI-ROLL BAR ASSY, □ 3/4, BALL PIVOT, G-BAR, 62-67 CHEVY II
74	2	3701	PRELOAD ADJUSTER ASSEMBLY BALL END ANTIROLL BAR
75	2	1262	LOCKING RING, 1 7/8-20 THREAD 1/2 DRIVE, BALL END ANTIROLL BAR
76	2	3157-038F-C	FENDER WASHER, 3/8 x 1 1/2, ZINC PLATED
77	2	3108-038L-C	LOCK WASHER, HELICAL SPRING □ 3/8, STEEL, ZINC
78	4	3100-038F1.50Y	HEX BOLT, 3/8-24 x 1 1/2, GRADE 8, YELLOW ZINC
79	2	1468	ANTI-ROLL STRAIGHT ARM, 1 1/4-48 SPLINE, 8.20 LONG
80	2	3108-038H-C	HIGH COLLAR LOCKWASHER, 3/8 STEEL, CLEAR ZINC
81	2	3103-038C1.75C	SOCKET HEAD CAP SCREW, GRADE 8, 3/8-16 x 1 3/4, CLEAR ZINC
82	2	3111-038X038-RT	ROD END, 3/8-24 RIGHT x 3/8 BORE, MALE, TEFLON, CM6T
83	2	1058	ADJUSTER, 4.0 x 3/8-24, ANTI-ROLL BAR
84	2	3111-038X038-LT	ROD END, 3/8-24 LEFT x 3/8 BORE, MALE, TEFLON, CML6T
85	2	3102-038-24RC	JAM NUT, 3/8-24 RIGHT, CLEAR ZINC
86	2	3102-038-24LY	JAM NUT, 3/8-24 LEFT, YELLOW ZINC
87	2	3140-1216-017	SLEEVE, □ 1/2 x .384 x .550
88	2	3140-1216-008	SLEEVE, □ 1/2 x .384 x 1/4
89	4	3101-038-24C	LOCNUT, 3/8-24, GRADE 5, NYLON INSERT, CLEAR ZINC
90	4	3109-038-S-2-Y	AIRCRAFT WASHER 3/8 x .062 THICK
91	2	3100-038F2.25Y	HEX BOLT, 3/8-24 x 2 1/4, GRADE 8, YELLOW ZINC

# PARTS LIST

Prior to installation use the following parts lists to verify that you have received all components.

## Torque Arm - 300-0188

1	3100-050F2.50Y	Bolt, 1/2-20 x 2-1/2" hex head Grade 8
1	3100-050F3.25Y	Bolt, 1/2-20 x 3-1/4" hex head Grade 8
1	3100-050F3.75Y	Bolt, 1/2-20 x 3-3/4" hex head Grade 8
3	3101-050-20C	Locknut, 1/2-20 nylon insert
6	3109-050-S-2-Y	Aircraft washer, 1/2" small OD
1	3144-25-28-0	Grease zerk, 1/4-28 straight
1	7959-0280	Torque arm weldment
2	7959-0287	Torque arm adjuster, 7/8" thread
2	7959-0288	Serrated washer, 1/2" ID
1	899-016-1.125W	Wiper seal, 1-1/8" ID

## Torque Arm Pinion Support Mount - OPTION *(You will receive one of the options listed.)*

1	300-0190	Ford 9" and Strange ST Iron 9"
1	300-0191	Strange Pro-Aluminum 9"

## Torque Arm Pivot Eye - OPTION *(You will receive one of the options listed.)*

1	7959-0157	Poly-bushing torque arm pivot
1	7959-0175	Pivot-ball torque arm pivot

## Torque Arm Chassis Crossmember - OPTION *(You will receive one of the options listed.)*

1	5858-U01	Torque arm crossmember, removable (weld-in)
1	5903-X10	Subframe g-Connectors, direct-fit (weld-in)

## Lower Suspension Links - OPTION *(You will receive one of the options listed.)*

1 set	300-0118	g-Link dual pivot-ball tubular lower link assembly, 24" long
1 set	300-0119	g-Link dual pivot-ball billet-aluminum lower link assembly, 24" long

## Lower Arm Chassis Brackets - 300-0179

1	7959-0245	Chassis bracket, driver side
1	7959-0248	Chassis bracket, passenger side

WITHOUT FAB9 - If your suspension system was ordered without a factory-welded FAB9 housing, the lower control arm axle brackets and fixture will be selected options. If ordered with FAB9 housing brackets will come factory welded to housing.

## Additional Components Required (weld-on by installer)

1	6731	Weld fixture for torque arm housing mounting tabs
4	7959-2017	Watts link base standoffs, 3/8-16 x 1" long
1	7959-0285	Torque arm serrated housing mount tab, driver side
1	7959-0286	Torque arm serrated housing mount tab, passenger side

## Axle Brackets (weld-on lower)

1	7959-0239	Lower axle bracket with anti-roll-bar bosses, driver side, weld-on
1	7959-0240	Lower axle bracket with anti-roll-bar bosses, passenger side, weld-on

## Watts Link Components

1	300-0185	Watts link hardware
1	300-0193-220W	Watts link rods, 22" length (pair)
1	300-0198	Watts frame bracket set, custom-fit

## Shock Absorber Components *NOTE: You will receive only one of the options listed below.*

1 (pair)	VAS 11111-515	Coil-over shocks, 5" travel, bearing eyes, single-adjustable (Q1)
1 (pair)	VAS 11211-515	Coil-over shocks, 5" travel, bearing eyes, double-adjustable (Q2)
1 (pair)	VAS 11411-50	Coil-over shocks, 5" travel, bearing eyes, 4-way remote reservoir (Q4R)
1 (pair)	VAS 131K2-515	Air-spring shocks, 5" travel, poly eyes, single-adjustable (Q1)
1 (pair)	VAS 132K2-515	Air-spring shocks, 5" travel, poly eyes, double-adjustable (Q2)

### Components for Coil-Over Shocks

1 (set)	VAS 508-105	Spacer set for bearing mount shocks
1	VAS 517-RS-F	Reservoir mount single-silo flat surface
1 (pair)	VAS 21-12110	Coil spring, 12" length, 110 lb/in rate
1 (pair)	VAS 21-12130	Coil spring, 12" length, 130 lb/in rate
1 (pair)	VAS 21-12150	Coil spring, 12" length, 150 lb/in rate
1 (pair)	VAS 21-12175	Coil spring, 12" length, 175 lb/in rate
1 (pair)	VAS 21-12200	Coil spring, 12" length, 200 lb/in rate
1 (pair)	VAS 21-12250	Coil spring, 12" length, 250 lb/in rate
1 (pair)	VAS 21-10200	Coil spring, 10" length, 200 lb/in rate (for Q4R shocks only)

## Upper Shock Crossmember - 6267

4	2101	Mounting tab 1/2" hole
2	3100-050F2.50Y	Bolt 1/2-20 x 2-1/2" hex head, Grade 8, yellow zinc
2	3101-050-20C	Locknut 1/2-20 nylon insert, plated
1	E26.134-048.000	Tube 1-5/8 x .134"-wall

## Lower Shock Mounts - 300-0106

1	1477-D	Shock mount, billet aluminum, driver side
1	1477-P	Shock mount, billet aluminum, passenger side
4	3100-038F2.00Y	Bolt, 3/8-24 x 2" hex head Grade 8
2	3100-050F2.75Y	Bolt, 1/2-20 x 2-3/4" hex head Grade 8
4	3101-038-24C	Locknut, 3/8-24 nylon insert
2	3101-050-20C	Locknut, 1/2-20 nylon insert
8	3109-038-S-2-Y	Aircraft washer, 3/8" small OD

## Splined-End Anti-Roll Bar - OPTION

Qty	Part Number	Description
1	300-0172	Anti-roll bar mounts and hardware
1	300-0194	Anti-roll bar 3/4" diameter, 1-1/4" 48-spline with 1" ball pivot ends

# INSTRUCTIONS

TACK WELD ALL COMPONENTS, TEST FIT, AND CYCLE THE SUSPENSION BEFORE FINAL WELDING.

The torque arm suspension system replaces each of the components in your factory rear suspension. It is necessary to remove all of the existing components to prepare for installation.

## Remove Factory Suspension

1. Raise vehicle to a safe and comfortable working height. Use jack stands to support vehicle with suspension hanging freely. Make sure it is level front to rear and right to left.
2. Remove driveshaft, then all rear suspension components.
3. Remove any portions of exhaust system that may interfere with installation. Mufflers in the stock location can remain in place. Unbolt or cut any exhaust tubing that is routed over the rear end housing.
4. Brake and fuel lines can remain on vehicle but will need to be secured along the body to prevent damage during installation.
5. The front leaf spring hangers will be removed using a cut-off wheel and upgraded to a stronger mounting bracket with standard Grade 8 hardware.
6. The replacement bracket fits over the frame rail and boxed understructure and moves the suspension link mount inboard. Grind all weld areas and tack weld to hold securely.

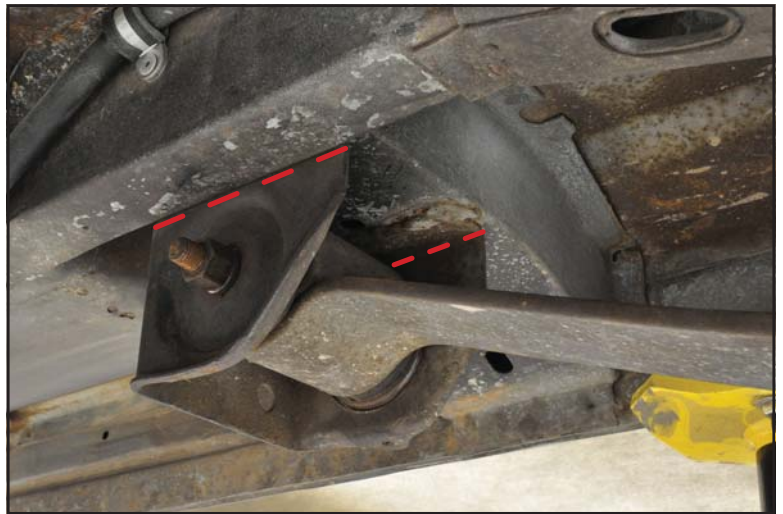

## Inspect Chassis

7. With the suspension out of the way, this is a good time to inspect the frame, mounting areas and sheet metal for signs of fatigue. Clean the area to remove any grease or dirt so the metal and welds are clearly visible. Any needed repairs will have to be made before proceeding.



## Position Rearend Housing

*Third-member and pinion support mount must be installed into rearend housing before proceeding. Longer bolts with washers are included.*

8. Place the rearend housing under the car on jack stands at approximate ride height position. You will need a third stand to support the pinion.

## Lower Suspension Links

9. Correct adjusted length is 24.00", measured at the center of the bolt holes. Due to chassis variances it may be necessary to adjust the lower suspension link lengths to position the rear end housing square to the chassis.
10. Install the lower suspension links at the front chassis mount using 1/2" diameter bolts, flat washers, and locknuts. Grease zerk fittings must point downward. Torque to 65 lb-ft.
11. Attach the lower suspension links to the axle brackets with 1/2" bolts, flat washers, and locknuts. Use the second hole from the bottom on the axle brackets for initial installation.



**Mounting Position:** The lower link has multiple mounting positions at the axle bracket. Ideally, to minimize suspension steering effects (roll steer), the link should be set as close to horizontal as possible with the suspension at ride height. Lowering the rear position from horizontal will also increase available traction, but also increases roll oversteer.

## Lower Shock Mounts

12. Install the billet lower-shock mounts at the lower axle bracket using 3/8" hardware. Leave two blank holes below the mount for initial setup.
13. Position rearend housing at intended ride height. The distance from the billet-shock-mount hole to the center upper-shock-mount hole must measure 13-1/2". This is the baseline ride-height position. The weld-in crossmember can be adjusted as needed during installation.

## Torque Arm Installation

*Center the housing in relation to the chassis before proceeding.*

14. The pinion support mount should already be installed onto the third-member.
15. Thread the two flanged adjusters into the torque arm. These are used for left to right alignment of the front pivot eye with the chassis bracket located on the crossmember.
16. Hang the torque arm from the adjustment mounts below the housing with the 1/2" x 3-3/4" bolt, locknut, and serrated washers. The serrations on the washers must face the adjustment mounts. Begin with arm in the center position for initial setup. This must be adjusted again after final positioning of all components.
17. Swing the torque arm upward and support with jack stand or hang from body in approximate position.
18. Attach arm to the pinion support mount using the 1/2" x 3-1/4" bolt, locknut, and flat washers.

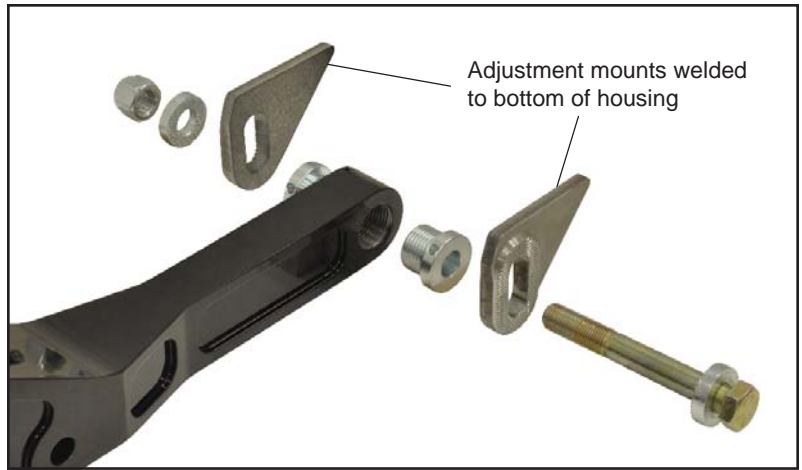

## Torque Arm Crossmember Installation

*Subframe g-Connectors must be installed at this time, if purchased. Crossmember can be welded to the factory frame rail if g-Connectors were not purchased.*

19. Seat the wiper seal into its groove, then lightly grease the inside bore before inserting the pivot slider. Install grease zerks at this time.
20. Position the torque arm pivot in the front mount hole that gets the pinion angle closest to correct. Use the rear serrated adjuster to fine tune pinion angle.



**First Step:** Position the rear axle at ride height, centered in chassis, at correct wheelbase and at the correct pinion angle. The torque arm serrated adjusters should be at center travel up and down and flanged adjusters centered right to left by turning both in the same direction, either up or down. An Allen wrench or punch can be used to rotate the adjusters. Once centered, the crossmember bracket must be aligned with arm pivot when welded.

**Second Step:** Position the front crossmember so the torque arm front pivot attaches to the center hole in the 3-hole bracket and torque arm pivot extends out from the torque arm 1". If the torque arm crossmember cannot be installed to attach the torque arm in the center hole, it can be positioned to a different hole. The 3-hole front mount is also a pinion angle adjuster. If you install torque arm pivot in top or bottom hole you will not be able to use it to adjust the pinion angle in one direction.



21. Once the pivot eye aligns with the bracket bolt it in place with the 1/2" x 2-1/2" bolt, flat washers, and locknut.
22. Verify that the housing is still at approximate ride height.
23. The 1/2" pinion support bolt must be loose enough to allow the bracket to pivot.
24. Pinion angle is adjusted by raising or lowering the rearmost mounting bolt within the slotted tabs. With the housing supported by the axle tubes, pushing up on the rear section of the arm will tilt the pinion upward.

NOTE: Carefully read the Pinion Angle section at the end of this installation guide before determining the correct pinion angle.



25. Make sure the serrated washers are interlocked with the housing tabs when tightening.

### Watts Link Installation and Tuning

*The mounting bosses for the Watts link pivot come pre-installed on your FAB9™ housing. Refer to the assembly drawings for installation.*

NOTE: The housing should already be centered in relation to the chassis from a prior step. During assembly, thread engagement of each rod end into the aluminum radius rod must be equal.



The Watts link provides positive lateral location with the least amount of side-to-side variance while within its intended travel range. Expect a noticeable improvement in cornering stability and more linear motion when transitioning into and out of turns. Cornering characteristics will also be identical in left or right turns, providing the vehicles other components and settings are symmetrical.

**SQUARING THE PIVOT** - With the rearend housing at ride height, the Watts pivot must be perpendicular to the ground or straight up and down to ensure the maximum amount of perfectly centered suspension travel. Lengthening or shortening both links will rotate the pivot without offsetting the rearend.

**CENTERING REAREND** - Lengthening one link while shortening the other will adjust the left to right position of the rearend housing. The center pivot may need to be resquared.

Tighten all mounting hardware and jam nuts after adjusting.

**ROLL CENTER HEIGHT** - The Watts pivot can be moved to one of four positions to affect the handling of the vehicle. Raising the pivot adjusts to vehicle oversteer. Lowering the pivot adjusts toward understeer.

### **Weld-In Upper Shock Crossmember**

*Follow the instructions included with the crossmember kit for installation.*

*NOTE: The eye-to-eye distance must measure 13.5" from the crossmember tabs to the lower shock mount.*

### **Shock Installation**

*Install the shocks without springs initially to allow easier movement of the suspension to check for potential clearance issues.*

26. Install shocks with spacers, 1/2" bolts, flat washers and locknuts.
27. Adjust both shocks to their softest setting, then temporarily install using 1/2 x 2-3/4" bolts with locknuts.
28. Nuts can be threaded on by hand so that bolts do not slip out during next step. Shocks will be used to limit travel during next step.
29. Using a jack, cycle the rear suspension through its full range of vertical travel and body roll in both directions to check for binding and potential clearance issues at all suspension joints and along the lengths of any moving parts including the rearend housing and tires.

# Making Adjustments

**IMPORTANT** - All adjustments must be made with the suspension positioned at ride height and in the following order to prevent binding.

1. Lower Control Arm - Adjust length for wheelbase.
2. Watts Link - Center housing. Torque arm front mount must be disconnected.
3. Torque Arm - Adjust left to right to align with chassis mount.
4. Torque Arm - Adjust for pinion angle.

## Shock Absorber Mounting Options

### Lower Mounting Position:

The lower shock mount can be moved to one of four positions to alter ride height in 5/8" increments.

**Spring Preload:** Refer to VariShock coil-over installation guide (899-031-200 or 899-031-220) for detailed information regarding spring preload and correct balance of travel at ride height.

**Under no circumstance should the lower spring seat be used to adjust the shock length at ride-height to less than 13" or more than 14". Damage to the shock absorbers will occur, and you will be charged to repair them.**



# Pinion Angle

## Understanding Pinion Angle

The often misunderstood pinion angle is simply the angle formed by the centerlines of the driveshaft and rear differential pinion gear where they meet at the rear u-joint. When the pinion angle is set correctly, it is the same angle, but in the opposite direction as the angle formed by the engine-transmission centerline and the driveshaft at the front u-joint (see illustration below). The pinion angle is usually adjusted to match the engine angle as it is easier to change. Contrary to popular opinion, pinion angle is not a tuning aid. Correctly set, it will balance the driveshaft u-joints minimizing vibration and power loss.

## Measuring the Drivetrain Angles

A digital protractor or smart level is the best tool to measure the required angles. Engine centerline measurement can be taken from the vertical surface of the transmission tailshaft, the oil pan rail, or the front face of the harmonic balancer. Most production vehicle drive-train angles will run slightly downhill towards the rear bumper. A typical measurement may be 2 to 3 degrees. Driveshaft centerline angles can be measured directly on the shaft tube. Pinion gear centerline angles can be measured on the universal joint yoke or axle housing flange. It is important to be careful how you position the measuring tool so all the angles have the same reference plane. Remember the measurements must be taken with the rear suspension collapsed to the correct ride height.

## Adjusting the Third Member Pinion Angle

As an example, a two-degree downhill drivetrain angle would require the third member to be set at two degrees with the snout slightly raised. Be sure to tighten the mounting hardware to the torque value specified after making adjustments..

Note: High traction vehicles operated for extended periods at full throttle, such as drag or road racing, may need to compensate for flex in the suspension system by setting the pinion angle an additional 1 to 2 degrees down to avoid drivetrain vibration.

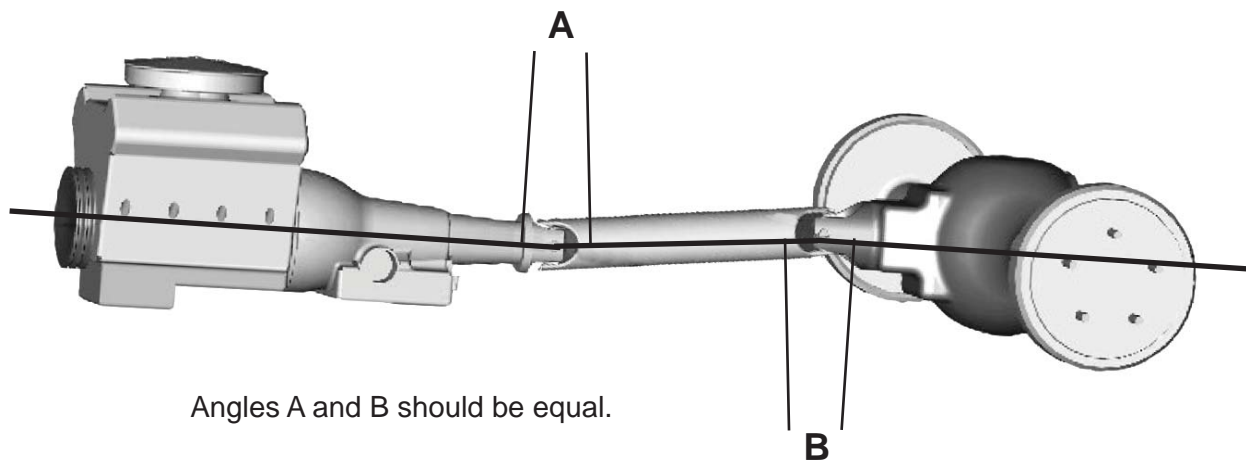

# Maintenance

## **Suspension Link Lubrication**

Each suspension pivot assembly can be lubricated using a standard grease gun. Pivot-ball links without a grease zerk fitting can be lubricated by removing the locking set screw and temporarily installing a zerk fitting.

## **Pivot-Ball Preload**

The retaining ring can be tightened to remove any free-play that develops in the pivot-ball mechanism. Remove the locking set screw and turn the retaining ring clockwise, using a common spanner wrench, to the next set screw position.

**NOTES:**

**NOTES:**

**WARRANTY NOTICE:**

There are NO WARRANTIES, either expressed or implied. Neither the seller nor manufacturer will be liable for any loss, damage or injury, direct or indirect, arising from the use or inability to determine the appropriate use of any products. Before any attempt at installation, all drawings and/or instruction sheets should be completely reviewed to determine the suitability of the product for its intended use. In this connection, the user assumes all responsibility and risk. We reserve the right to change specification without notice. Further, Chris Alston's Chassisworks, Inc., makes **NO GUARANTEE** in reference to any specific class legality of any component. **ALL PRODUCTS ARE INTENDED FOR RACING AND OFF-ROAD USE AND MAY NOT BE LEGALLY USED ON THE HIGHWAY.** The products offered for sale are true race-car components and, in all cases, require some fabrication skill. **NO PRODUCT OR SERVICE IS DESIGNED OR INTENDED TO PREVENT INJURY OR DEATH.**

Chris Alston's Chassisworks  
8661 Younger Creek Drive  
Sacramento, CA 95828  
Phone: 916-388-0288  
Technical Support: [sales@cachassisworks.com](mailto:sales@cachassisworks.com)

