

READ ALL INSTRUCTIONS COMPLETELY AND THOROUGHLY UNDERSTAND THEM BEFORE DOING ANYTHING.
CALL CHASSISWORKS TECH SUPPORT (916) 388-0288 IF YOU NEED ASSISTANCE.

INSTALLATION GUIDE

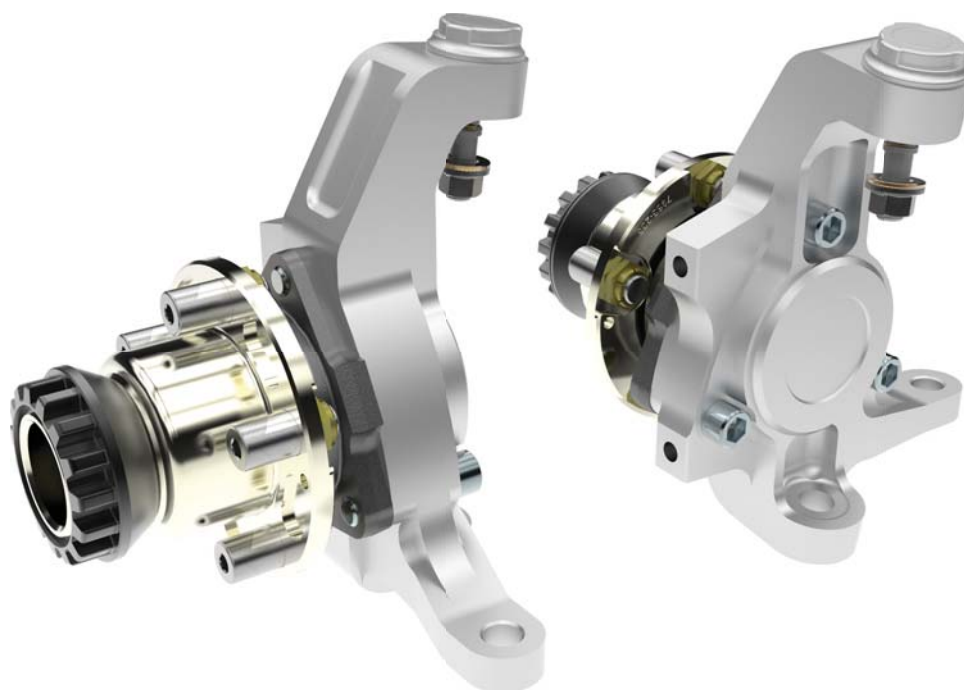

5737-SM1-FC g-Street Billet-Aluminum Upright for Forgeline-Style Center-Lock Wheels Only



Description: Billet-aluminum upright for Chassisworks gStreet suspension system.

Includes: Aluminum uprights with unit-bearings, steering arms for 5/8" rodend-style tie-rod end.

Note: Minimum rim size 18" or 19" depending upon brake rotor size and inside wheel clearance. Requires Chassisworks GT-style center-lock nuts; must purchase separately.

PARTS LIST

5737-SM1-FC (LONG) - Billet Uprights with Long Center-Lock Assembly

1	7964-106	Aluminum upright assembly (long center-lock) gStreet system, driver side
1	7964-107	Aluminum upright assembly (long center-lock) gStreet system, passenger side

5737-SM1-FC (SHORT) - Billet Uprights with Short Center-Lock Assembly

1	7964-108	Aluminum upright assembly (short center-lock) gStreet system, driver side
1	7964-109	Aluminum upright assembly (short center-lock) gStreet system, passenger side

Hardware required for initial assembly; included with A-arms.

2	3110-050-20-8Y	Hex nut, 1/2-20 Grade 8 (Included with gStreet upper A-arm) <i>Not used in kit. For assembly purposes only.</i>
2	3110-056-18-8Y	Hex nut, 9/16-18 Grade 8 (Included with gStreet lower A-arm) <i>Not used in kit. For assembly purposes only.</i>
2	3120-056S-Y	Washer, 9/16 flat hardened
1	3144-25-28-0-L	Grease zerk fitting, 1/4-28 straight (Included with gStreet lower A-arm) <i>Not used in kit. For assembly purposes only.</i>

Center-Lock Hardware Required

1	7963-251	Center-Lock GT Nut, left side, RH thread, bare finish (for KOFL-CL-1R)
1	7963-252	Center-Lock GT Nut, right side, LH thread, bare finish (for KOFL-CL-1L)
1	FLM KOFL-CL-1L	Forgeline Flush-Loc, left side, RH thread
1	FLM KOFL-CL-1R	Forgeline Flush-Loc, right side, LH thread
1	FLM KOFL-WRENCH	Forgeline Flush-Loc cap wrench

INSTRUCTIONS

Uprights are shipped factory-assembled with the correct amount of preload adjustment at the upper pivot.

Non-locking hex nuts are packaged with the gStreet upper and lower A-arms. These are used for assembly purposes only and will not be used in the final assembly.

Attaching Lower Pivot Stud

Parts/Tools Needed:

- Aluminum upright
- 9/16" hardened flat washer (included with lower A-arm)
- 9/16" hex nut, non-locking (included with lower A-arm)
- Allen wrench, 1/4"
- Small torch
- Thermometer (digital or mercury)
- Infrared heat gun thermometer

1. To form an extremely secure union of the two parts the joint is designed as an interference fit that requires heating the upright to expand the bore diameter. Make sure the mounting boss and pivot stud are free from any debris that could interfere with them fitting together properly.
2. Using the small torch, heat the lower boss to 325-350 Fahrenheit to expand the bore diameter enough for assembly. A digital cooking thermometer or IR thermometer should be used.

**DO NOT PUT INTO OVEN.
SPINDLE WILL BE DAMAGED.**



Digital Cooking Thermometer

Lay the thermometer probe as flat as possible against the upright.



These steps must be performed somewhat quickly so as not to allow the aluminum time to cool down.

3. Put anti-seize on pivot stud threads only, before inserting into hole in spindle. Place the upright over the lower pivot stud. At the correct temperature range, the bore will be large enough to insert stud by hand with light force.
4. Place the flat washer over the stud then start the hex nut. Use caution, the upright will be hot.
5. Tighten the hex nut until the stud flange is seated tightly against the bottom of the upright.
6. The upper pivot stud is drawn through the control arm boss using the 1/2" non-locking hex nut included with the arm. **Heat is not required for this joint.**
7. Put anti-seize on pivot stud threads only before inserting into hole in spindle. Tighten the hex nut until the stud shoulder is seated against the top of the control arm.



8. The hex nuts must be replaced by the locknuts for final assembly. The locknuts are intended to be single use to maximize their locking strength.
9. Torque locknuts to following specs: lower 9/16" nut to 130 lb-ft, upper 1/2" nut to 90 lb-ft. The 1/4" hex allen wrench must be used to prevent the pivot studs from spinning.
10. **IMPORTANT:** Apply anti-seize on the wheel nut before threading on the spindle. Failing to do so can result in the threads galling potentially weakening their integrity and leading to catastrophic damage.

MAINTENANCE

Adjusting Balljoint Preload

Balljoints are factory-preset with the correct amount of preload for low friction joint with zero freeplay. However, after regular use the joints must be tightened to remove any freeplay. This is part of regular vehicle maintenance and should be checked periodically.

To change preload in the upper balljoint (in upright) or lower balljoint (in A-arm):

1. Unscrew the three-lobe aluminum cap. Tension from an O-ring prevents the cap from unscrewing during normal use. If the cap cannot be easily unscrewed, Chassisworks offers a double-ended wrench that will remove the small-upper and large-lower caps (P/N 7964-081).
2. Remove the locking setscrew.
3. Rotate large threaded housing to loosen or tighten the balljoint preload. If you cannot turn the housing by hand, use an adjustable-pin spanner wrench.

To add grease to the assembly without disassembling the lock ring:

1. Remove the setscrew.
2. Install the grease zerk fitting shipped with lower control arm.
3. Use grease gun, then replace setscrew and cap.

WARRANTY NOTICE:

There are NO WARRANTIES, either expressed or implied. Neither the seller nor manufacturer will be liable for any loss, damage or injury, direct or indirect, arising from the use or inability to determine the appropriate use of any products. Before any attempt at installation, all drawings and/or instruction sheets should be completely reviewed to determine the suitability of the product for its intended use. In this connection, the user assumes all responsibility and risk. We reserve the right to change specification without notice. Further, Chris Alston's Chassisworks, Inc., makes **NO GUARANTEE** in reference to any specific class legality of any component. **ALL PRODUCTS ARE INTENDED FOR RACING AND OFF-ROAD USE AND MAY NOT BE LEGALLY USED ON THE HIGHWAY.** The products offered for sale are true race-car components and, in all cases, require some fabrication skill. **NO PRODUCT OR SERVICE IS DESIGNED OR INTENDED TO PREVENT INJURY OR DEATH.**

Chris Alston's Chassisworks
8661 Younger Creek Drive
Sacramento, CA 95828
Phone: 916-388-0288
Technical Support: sales@cachassisworks.com

