

VOLUME

18.2

5 DOLLARS

# CHRIS ALSTON'S Chassisworks

THE HOME OF HIGHER TECHNOLOGY

## gStreet Ultimate Pro-Touring Chassis

Pro-Touring - Muscle Car - g-Machines - RestoMods



*"The ultimate bumper-to-bumper chassis solution for high-horsepower, big-tire, pro-touring projects..."*

**Applications:**

- '67-69 Camaro
- '67-70 Mustang

*Ask us about your vehicle!*



Ultimate Pro-Touring State

**g Street** WAY

(800) 722-2269

www.CAChassisworks.com

# Letter to Customers

Dear Customers

I would like to take a moment to thank the thousands of you who have purchased products from me during my 35 years as a chassis components manufacturer. I am continually reminded by your letters, emails & car show visits that I have the best job in the world. I get to dream up magic stuff to modify your cars. Then, I get to build it in the coolest high-tech factory you can imagine.

Chassisworks remains committed to the development and manufacturing of components for your street and race chassis applications. Our investment in technology — both on the factory floor and in our business systems — has been critical to this company's continued success. No other chassis component supplier has made this size of commitment to utilize the very best equipment and processes for the design, testing and manufacturing of their products. This is why Chassisworks' designs are the most-copied. Because Chassisworks has the most-advanced automated factory, ours is the only company able to develop and produce state-of-the-art products made in America at competitive prices.

Our ability to continuously invent and refine products is made possible by our in-house research-and-development center. Chassisworks has a large scanning coordinate measuring machine to fully document the exact size of specific car components or complete vehicles to exactly determine the correct dimensions for any new retro fit component. The end result of this attention to detail is the legendary Chassisworks fit.

Because we actually install Chassisworks products on cars and trucks, we ensure that every part fits and works correctly before it's offered to you. Besides inspiring fresh ideas, this hands-on process ensures a constant refinement of existing components. It also gives Chassisworks the foresight to make our chassis and suspension products easier for the home builder to install.

Our ever-growing NoFab products, featuring the enormously successful line of bolt-on front clips and rear g-Bar™ have been expanded to include g-Street™ coilover-conversion front suspensions that are installed with ordinary hand tools — without welding. This is an example of how our technological advantage benefits our customers. Our newest additions to our product line have pushed the count of Chassisworks manufactured components to above 9,000. We provide more options and choices than anyone in the chassis business, period. Around here, "state-of-the-art" isn't just a sales slogan. Rather, it represents millions of dollars invested in high-technology equipment. It stands for the thousands of hours devoted to getting those 9,000 components right, the first time. It means we have gone above and beyond what the other guy has done to make our products more sophisticated and affordable.

Our VariShock line of shock absorbers is enormously popular and includes product applications for most American cars from 1955 to present including direct-fit adjustable struts. You may not even realize that you already have VariShock products on your car. A large portion of our production is sold to other companies to brand as their own. Designed and manufactured by us, VariShocks are the latest example of how Chassisworks constantly strives to develop revolutionary products — and why we lead the market in higher technology.

Our expanding road show visits over 50 venues each year. Check our web site schedule for the next event location near you, where you can get expert technical advice and see the Chassisworks products in person.

Because Chassisworks actually manufactures the majority of the parts on these pages, I'm proud to guide you on a pictorial tour of our state-of-the-art manufacturing facility. A much more detailed version of our shop tour is online.



Welcome to Chassisworks: The Home of Higher Technology.

Chris Alston



# Table of Contents

Letter to Customers ..... 2  
 Table of Contents..... 3



**gStreet Pro-Touring Chassis System ..... 4**  
 Body Fixture..... 20  
 Body Cart..... 22



'67-69 Camaro gStreet Front Strut..... 23  
 gStreet Exact-Fit Roll Cage ..... 24  
 gStreet Exact-Fit Roll Bar ..... 27



g-Machine Adjustable A-Arms ..... 28  
 g-Machine Suspension Accessories..... 29  
 gStreet Billet Upright and Brake Kit..... 30  
 gStreet Billet-Aluminum Upright..... 31  
 gStreet Threaded Bump-Steer Kit..... 32  
 gStreet 14" and 15" Front Brake Kits ..... 33



g-Machine-System Rack and Pinions ..... 36  
 g-Machine-System Power Steering Pump ..... 37

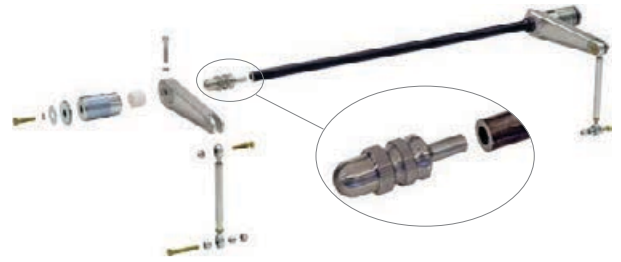

Billet Gun-Drilled Anti-Roll Bar ..... 38  
 Custom-Fit Canted 4-Bar Anti-Roll Bar..... 39



9" Third-Member Packages..... 40  
 Custom Axle Packages ..... 41  
 Pro-Touring Floater Axle System ..... 42



14" and 13" Rear Discs with Parking Brake..... 50  
 Street 12.19" Rear Discs with Parking Brake ..... 51  
 Tandem Chamber Master Cylinders ..... 52  
 Brake System Accessories ..... 53



VariShock Technology ..... 54  
 VariShock Coil-Overs..... 56  
 Remote Reservoir 4-Way Coil-Over..... 57  
 Coil-Over Shock Accessories ..... 61  
 VariSpring Coil Springs ..... 62

**Terms and Conditions..... 63**

# gStreet Pro-Touring Chassis System

■ NEW PRODUCT

*"The ultimate bumper-to-bumper chassis solution for high-horsepower, big-tire, pro-touring projects..."*

## Applications:

- • '67-81 Camaro/Firebird
- • '67-70 Mustang
- • Additional applications coming soon!



Options and prices shown on following pages.

The ultimate bumper-to-bumper chassis solution for high-horsepower, big-tire, pro-touring projects is now available as an off-the-shelf item. Builders can take advantage of Chassisworks' robust engineering and manufacturing capabilities, saving hours of fabrication time and effort, while significantly shortening the timeframe to deliver a top-tier performance vehicle.

The complete system consists of the following: Chassisworks' fabricated front subframe with modified engine position and drivetrain angle; replacement double-walled rockers; 3 x 2" subframe connectors; choice of 4 x 2" canted-4-link or torque arm with watts link rear frame; fabricated transmission-tunnel and lowered seat-mount assembly; complete interior tin kit, including front and rear floor, wheel tubs, trunk floor, and rear firewall. The exact-fit roll bar or roll cage with forward support struts can be added to create an extremely rigid performance platform suitable for 1,000 horsepower engine combinations, with room for large enough tires to put that much power to good use.

Increasing wheel well clearance to accommodate larger high-performance tires was extremely important. In the '67-69 Camaro example shown in this section, the front subframe accommodates tires up to a 13.18" section width with 26.9" overall height (335/30-19) with a full 30-degree turning angle; some restrictions apply. The rear has ample room for 14.25" section-width tires with 28.2" overall height. The



prefabricated wheel tubs allow room for even larger tires when they become available.

## Features/Benefits:

- Front Tires: Fits up to 335/30-19 (13.18" section width, 26.9" overall diameter) Some restrictions apply. (Camaro specific)
- Rear Tires: Fits 345/30-20 (14.25" section width, 28.2" overall diameter) (Camaro specific)  
*Room for larger tires when they become available*
- Fully-optioned system engineered to support over 1,000 hp in performance handling applications
- Double-A-arm front suspension with rack-and-pinion steering
- Highly adjustable geometry - canted-4-link or torque arm with watts link rear suspension
- Available in full-frame, firewall-back, and back-half configurations

NOTE: Refer to the Custom-Fit Chassis System section of this catalog for a closer look at individual suspension and steering components.

# gStreet Pro-Touring Chassis System

■ NEW PRODUCT

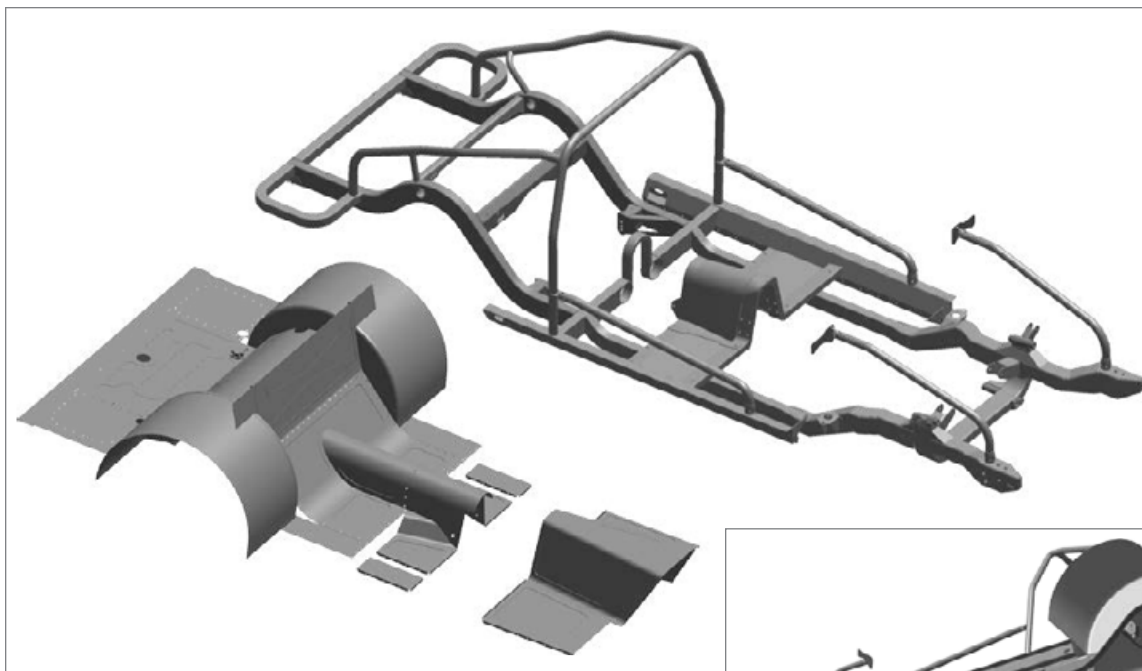

*"...saving hours of fabrication time and effort, while significantly shortening the timeframe to deliver a top-tier performance vehicle."*

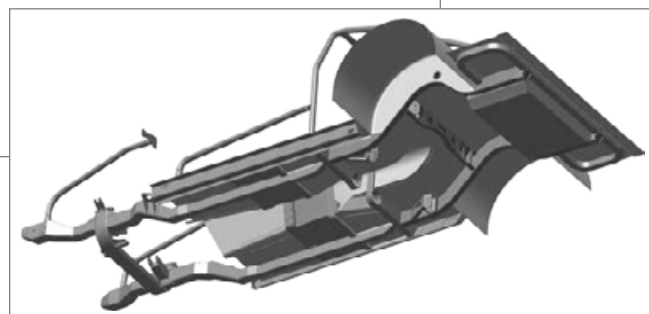

*"Fits 345/30-20 (14.25" section width)...  
Room for larger tires when they become available."*

# gStreet Pro-Touring Chassis System

NEW PRODUCT

## 1967-69 CAMARO GSTREET FRAME SYSTEM SHOWN

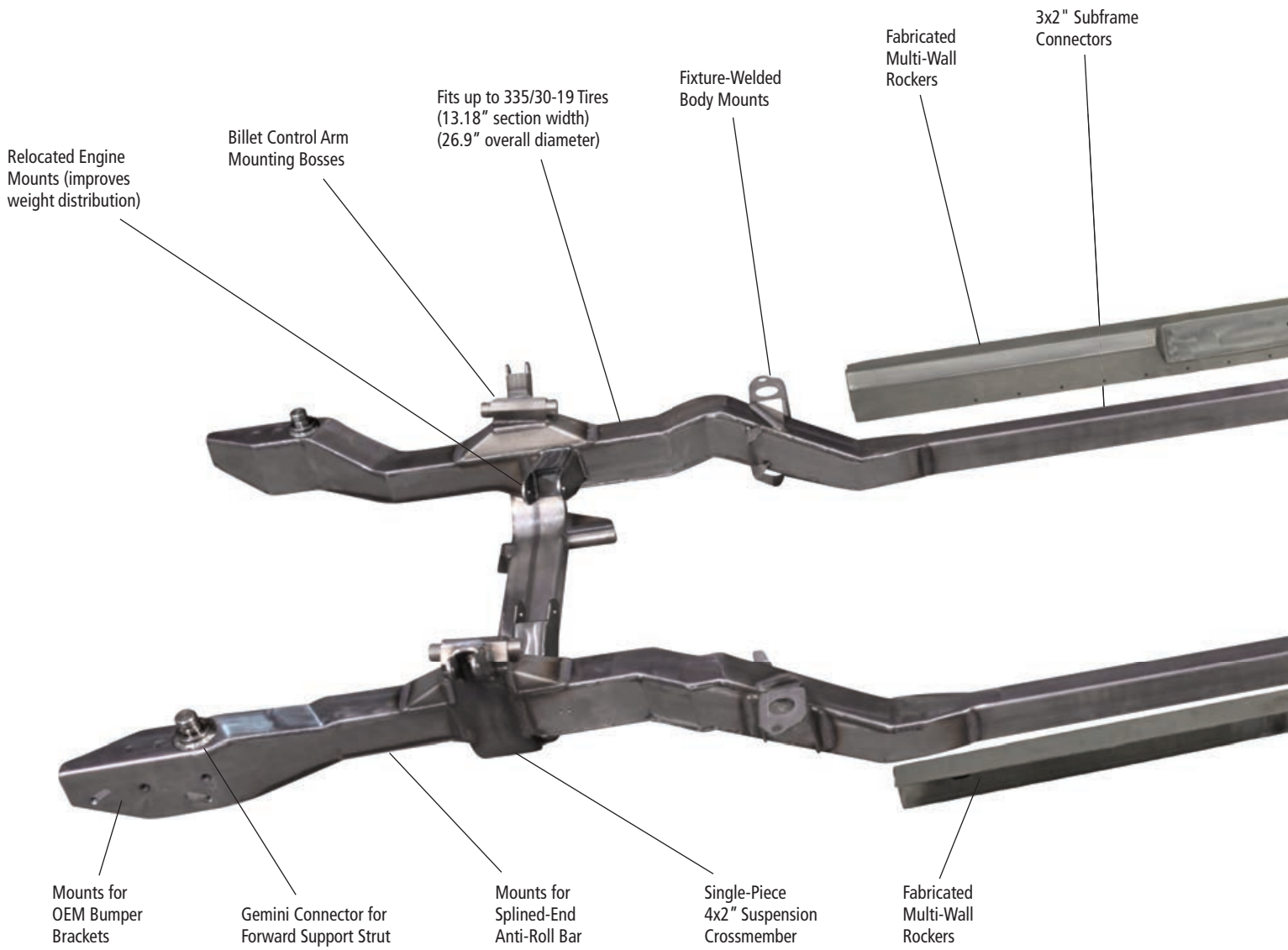

# gStreet Pro-Touring Chassis System

NEW PRODUCT

## 1967-69 CAMARO GSTREET FRAME SYSTEM SHOWN

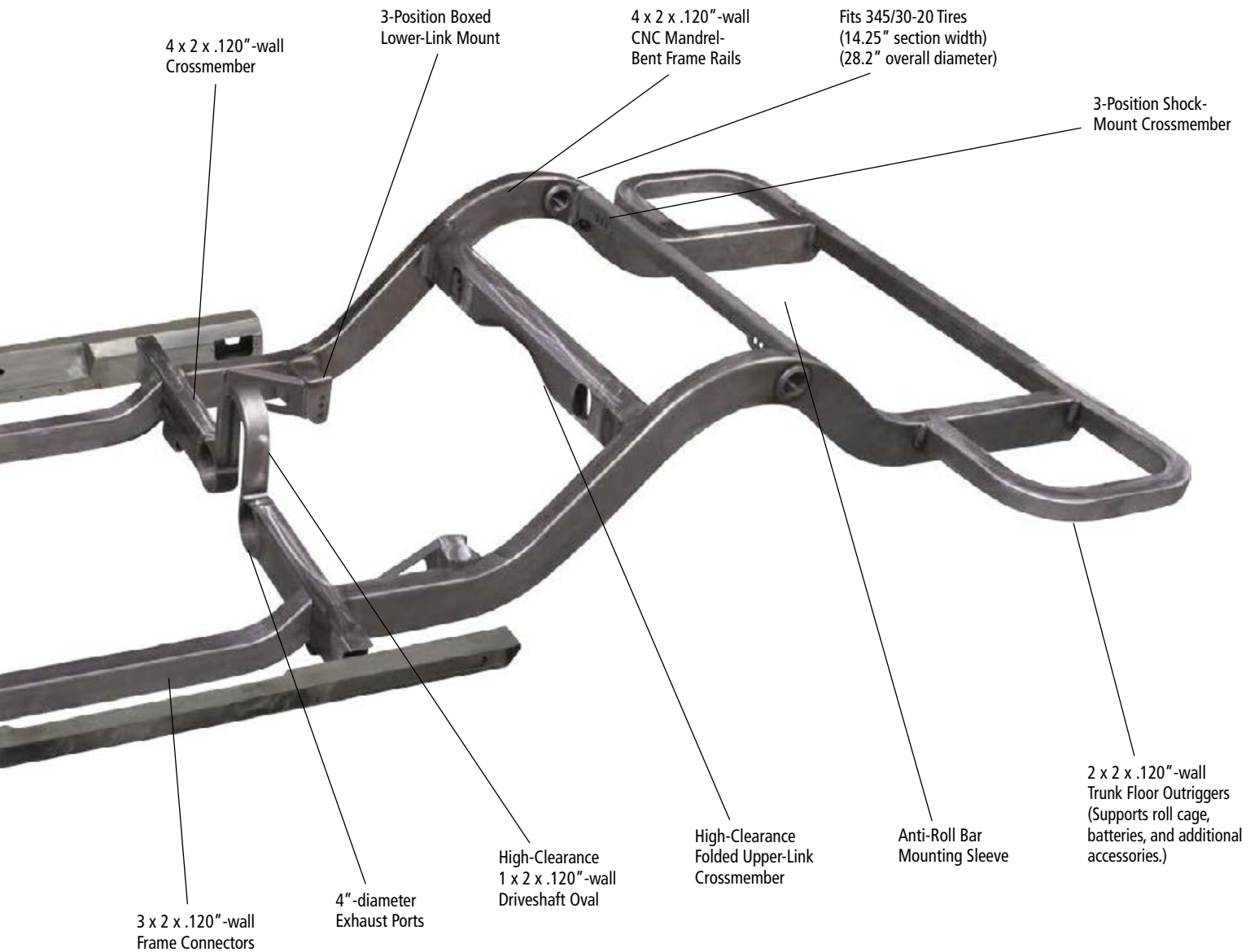

# gStreet Pro-Touring Chassis System

■ NEW PRODUCT

## ■ FRONT SUBFRAME SYSTEM

Similar in construction to Chassisworks existing double-A-arm Camaro subframe, the enhanced gStreet subframe features redesigned frame rails to increase maximum tire section width from 285 to larger 335-wide (13.18") tires; some restrictions apply. Engine mounts are repositioned rearward to improve weight distribution and leveled to provide bellhousing, transmission and exhaust clearance necessary for the significantly lower ride height of the complete frame system.



Locating features are machined into each crossmember to enable self-positioning of billet components.



Billet rack-and-pinion mount inserts into machined crossmember slot.

## ■ One-Piece 4 x 2" g-Machine Crossmember

Bent-tube, billet-component crossmembers are a completely closed, rigid structure with greater strength and resistance to bending and twisting than other designs. Formed from a single piece of 4 x 2 x .120" steel tubing, large-radius mandrel bends are placed at each end to distribute loads throughout the crossmember, eliminating fatigue points at critical areas. Slots for the billet-mount tabs are machined in a large horizontal machining center with dedicated fixturing to guarantee correct component geometry, ensuring the suspension moves as designed.

## ■ Interlocking-Slot-Tab Technology

Self-fixturing female slots used with machined male tabs provide an interlocking assembly method that enables A-arm, rack and pinion, and shock mounts to be accurately positioned in all axes. This guarantees the suspension will perform as designed. Non-interlocking designs are not nearly as accurate after welding. Superior spray-arc welding process produces the best weld penetration with excellent appearance.

## ■ Billet-Aluminum Body Bushings

6816 '67-81 CAMARO/FIREBIRD \$92.00

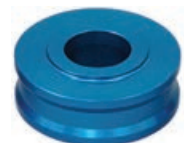

## Billet-Aluminum Side Motor Mounts

5917-LS-L-1	CHEVROLET LS SERIES (LONG), ANODIZED ALUMINUM	\$295.00
6055-0	CHEVROLET SB, BB, V6, BARE FINISH	174.00
6055-1	CHEVROLET SB, BB, V6, ANODIZED FINISH	195.00
6055-2	CHEVROLET SB, BB, V6, POLISHED FINISH	215.00
5917-PV8	PONTIAC V8, BILLET STEEL AND WELDED CONSTRUCTION	298.00



LS-Series



Small-Block,  
Big-Block, V6

## REPLACEMENT DOUBLE-WALL ROCKERS

A significant amount of chassis strength and rigidity is gained by installing the optional prefabricated double-wall rocker sections. The inside shell of the OEM rocker is removed, revealing the empty outer-body wall, and replaced with the heavier-walled Chassisworks' rocker with boxed interior structure. Seat belt mounts and wiring access channels are built into the rockers to simplify final vehicle assembly. The improved rocker provides a far superior structure on which to mount the rear-frame crossmember and roll bar or roll cage. Main hoop and cage side reinforcement plates, such as those used on OEM sheet metal, are not required with the Chassisworks' rockers.



**Firewall Rocker End (left):** The new rocker extends through the firewall and features a large support gusset.

**Stainless Caps (left/right):** Access holes at each end of the rocker allow wiring or plumbing to be safely routed through each rocker structure. Removable stainless steel caps are provided for easier installation of bulkheads or grommets.



## ■ FRONT SUSPENSION PACKAGE

### Suspension

- g-Machine Adjustable Upper Control Arms with polymer pivot bushings
- g-Machine 1-1/4" Crossbraced Lower Control Arms with polymer pivot bushings
- Billet-Aluminum Upright
- Infinitely Adjustable Bump-Steer Kit



### VariShock Shock Absorbers

- 4-Way Adjustable Remote Reservoir Shocks
- Double-Adjustable Coil-Over Shocks
- Single-Adjustable Coil-Over Shocks
- VariSpring Coil Springs with choice of rate



### Anti-Roll Bar

- Adjustable-rate, billet steel arms
- Lightweight gun-drilled bar
- Billet-aluminum mounts with low-friction polymer bearings
- Adjustable-length spherical-bearing endlinks



NOTE: Refer to the Custom-Fit Chassis System section of this catalog for a closer look at individual suspension and steering components.

## FRONT SUSPENSION PACKAGE

### Rack & Pinion

- Power Rack and Pinion with billet-aluminum mounts
- Left- or right-hand drive versions



### Brake Options

- 15 x 1.25" -wide, cross-drilled rotors with black E-coat finish
- 14 x 1.25" -wide, cross-drilled rotors with black E-coat finish
- Wilwood Aero6 6-piston, radial-mount calipers (black, red, or nickel with Thermlock® pistons)
- Baer 6S 6-piston, forged-monoblock calipers (black, red, or silver powder-coat finish)



## ■ REAR SUSPENSION PACKAGE



### Suspension Links

- g-Link Upper Arms
  - Billet alloy steel with low-friction, pivot-ball ends
  - Double-adjustable link with increased pinion angle adjustment range
- g-Link Lower Arms
  - Tubular 4130 steel with pivot-ball ends
  - Adjustable length for proper alignment



### Anti-Roll Bar

- Ball-End Anti-Roll Bar with billet-aluminum arms
- Low-friction polymer pivot bearings
- Eliminates bulky mounts; fits tight to underbody



## ■ REAR SUSPENSION PACKAGE

### VariShock Shock Absorbers

- 4-Way Adjustable Remote Reservoir Shocks
- Double-Adjustable Coil-Over Shocks
- Single-Adjustable Coil-Over Shocks
- VariSpring Coil Springs with choice of rate



### Billet Shock Mounts

- 3-1/2" ride-height adjustment range to accommodate different tire diameters
- Billet-aluminum construction
- Double-shear mounted



### FAB9 Rearend Housing

- Fabricated mild-steel or 4130 sheet metal construction
- Multiple suspension mounts to adjust geometry



## ■ BACK-HALF REAR FRAME

Chassisworks' canted 4-bar Camaro rear frame system is a truly versatile high-performance suspension solution, suitable for high-power, big-tire, pro-touring projects that require more strength and stiffness than systems mounted to the OEM sheet metal can provide. Achieving a very low rocker ground-clearance height of 4" with massive rear tires was one of the system goals. We are proud to state that nearly all of the normally 'one off' chassis and sheet metal fabrication that is required to tuck extremely large tires, drivetrain, and exhaust into your Camaro is expertly built into a neatly packaged 'off the shelf' system. To ensure perfect geometry and fit with minimal effort while saving considerable installation time, rear frames including front crossmember ship as a factory-welded subassembly with unattached 2 x 2" trunk outriggers and 3 x 2" front subframe connectors for easier installation. The 4 x 2 x .120"-wall rear frame is designed with minimal rise over the rearend housing and maximum clearance above the driveshaft and third-member to allow more room in the rear seat and trunk areas without sacrificing suspension travel.

## Features/Benefits:

- Fits 345/30-20 rear tires (13.5" section width) (28.2" overall diameter)
- Highly adjustable triangulated 4-link rear suspension
- 4 x 2 x .120"-wall boxed tubing frame rails stronger than OEM
- Supported trunk floor for NoFab battery mount and fuel tank
- Ships as factory-welded assembly
- Complete line of NoFab accessory components to complete build



## ■ Frame Manufacturing

All components are professionally spray-arc-welded by Chassisworks' welding staff in a controlled environment using computer-designed fixtures and production-quality equipment.



Tall driveshaft loop allows body to sit lower over the drivetrain without risk of driveshaft contact. Crossmember features factory-welded, dual 4"-ID exhaust ports.

## BACK-HALF REAR FRAME

Multiple mounting points for each of the suspension components, including shocks, control arms, and anti-roll bar, enable highly adjustable suspension geometry that can be fine-tuned to match the performance requirements and weight distribution of your specific vehicle. Suspension component options include tubular-steel or billet-aluminum suspension links with pivot-ball ends, factory-welded FAB9 housing, ball-end anti-roll bar, and VariShock coil-over or air-spring shocks.

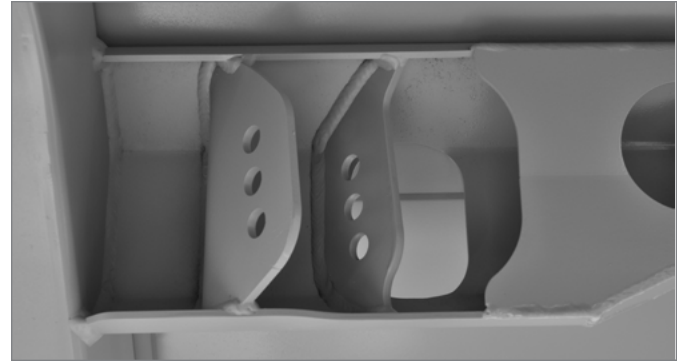

3-Position Upper Control Arm Mount



3-Position Lower Control Arm Mount

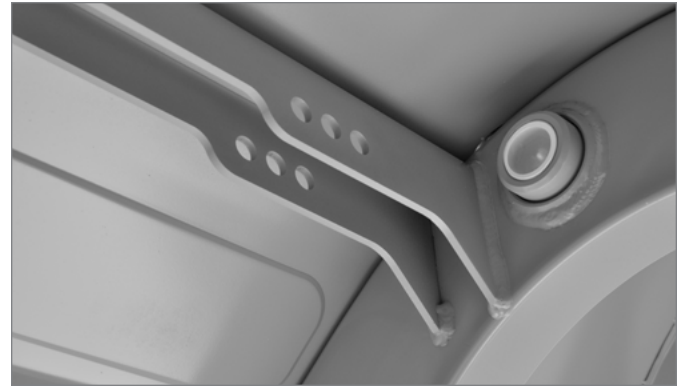

3-Position Upper Shock Mount

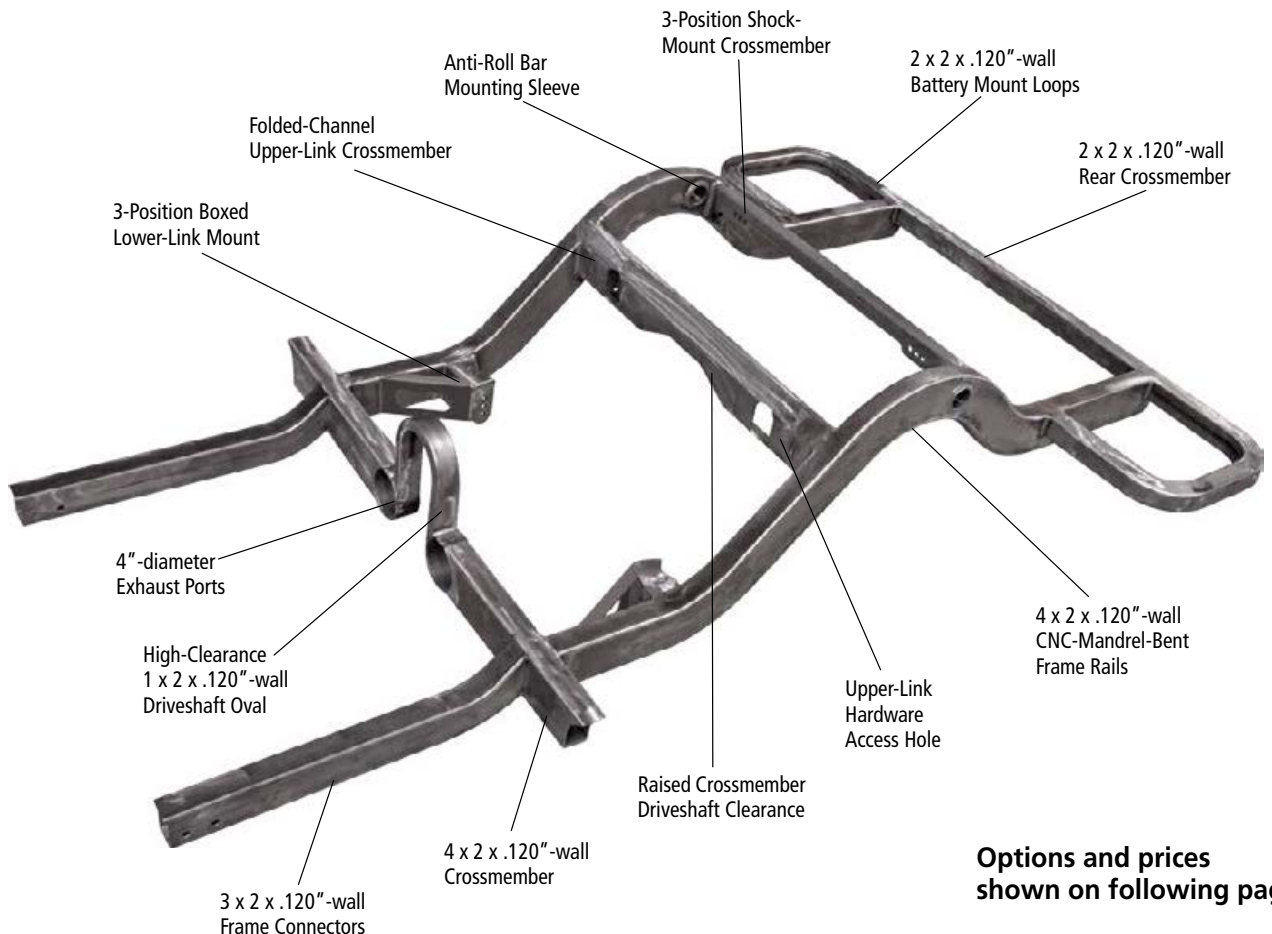

Options and prices shown on following pages.

## FACTORY-WELDED SEAT MOUNT ASSEMBLY

The seat mount area can be an extremely time-consuming area of the chassis to manually fabricate. Seating position, overall rigidity of the area, strength of the mounting bosses, and adequate drivetrain clearance are all extremely important for safety and comfort. Chassisworks addresses these issues with a prefabricated, factory-welded assembly (shown below) that simply drops into place for final welded installation.

To improve driver comfort, the seating position is lowered 1" to provide additional headroom and increase visibility below the windshield brace. The front crossmember is specially fabricated to cleanly transition from the tunnel's sharper bends over the transmission to the larger U-bent panel between the front seats. The rear of the hump features a layered inset to perfectly position the adjacent hump panel. Rear tubular supports are notched to achieve the lower seating position and straddle the subframe connector. All seat and safety harness mounting locations are integrated into the factory-welded assembly.



Installed lowered-seat-mount assembly shown with prefabricated front floor, transmission tunnel, driveshaft tunnel, and rear floor.

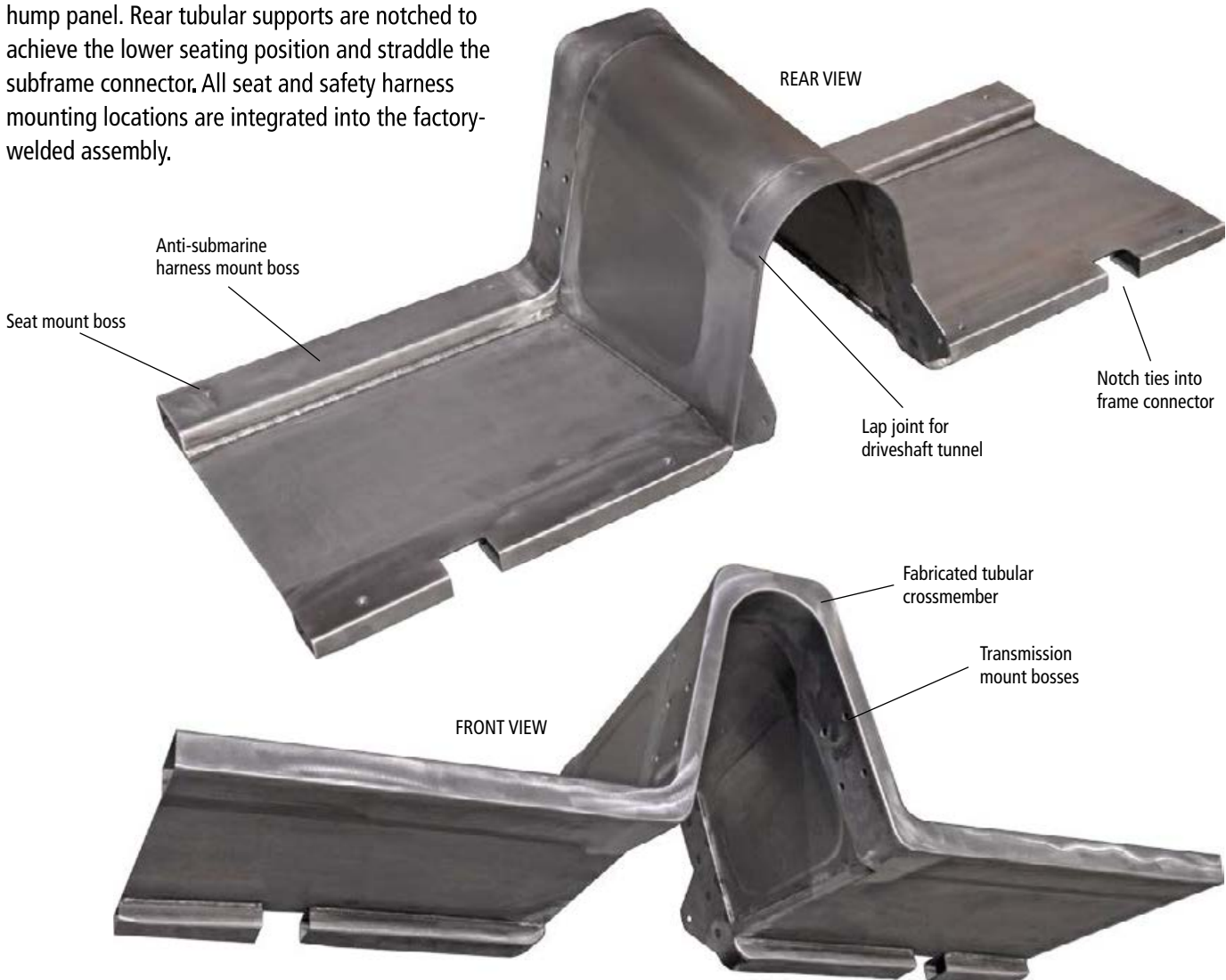

# gStreet Pro-Touring Chassis System

■ NEW PRODUCT

## ■ PREFABRICATED FLOOR AND WHEEL TUB KIT

The Camaro prefabricated floor kit replaces ALL floor and drivetrain-tunnel sheet metal from the base of the firewall to the rear tail lamp panel. Large sheet metal spans are

bead-rolled to strengthen each panel, significantly reducing flex and vibration. To facilitate clean, rapid, and accurate installation, folded lips, inset lap joints, and plug-weld holes are designed into each component.



The rear floor panels feature contoured flares for exhaust clearance; note the intricate fit of the tunnel, floor, and rear seat pan. The height of the driveshaft tunnel section and wheel tubs also hint at the position of the rearend housing in relation to the vehicle floor. The seat pan and rear firewall show the pre-drilled plug-weld holes, a simple but timesaving feature.



To accommodate the significantly lowered ride height of the frame system, the transmission and tunnel have been moved upward. The drivetrain tunnel provides adequate clearance for the larger T-56 transmission and dual 3"-diameter exhaust.



The optional stainless steel fuel tank really completes the look of the trunk. Sending unit and trunkfill gas cap are shown. A remote-fill hardware set is also available.



The rear seat pan follows the top edge of the frame rails and continues into the trunk. This installation shows the optional remote shock reservoir mount insert. The wheel tubs, fuel tank, and side panels close out the trunk floor. An optional billet battery mount is also available.

## FUEL SYSTEM

### Fuel Tank

- Direct bolt-in installation
- TIG-welded, Stainless-steel construction
- Bead-rolled panels

### System Accessories

- Aluminum aircraft fuel cap
- Sending unit
- Fuel filter



Bead rolled panels



Stainless bulkhead



Mounts flush with trunk floor



Remote-fill option



Sending unit and filter



Aircraft fuel cap



## gStreet Chassis Kits - Prices and Options

### ■ gStreet Full-Frame Package

7740-F10	GSTREET CHASSIS 67-69 CAMARO & FIREBIRD CONTAINS: WELDED A-ARM & 4-LINK/TORQUE ARM FRAME, ENGINE AND TRANSMISSION CHASSIS MOUNTS, INNER ROCKER PANELS, ROLL BAR, SEAT PLATFORM TUNNEL TRANSITION, COMPLETE FLOOR BEHIND FIREWALL WITH TRANSMISSION & DRIVESHAFT TUNNELS, WHEEL TUBS & PACKAGE TRAY BULKHEAD, ACCEPTS G-MACHINE OR PRO-BILLET UPRIGHT FRONT SUSPENSION, 4-LINK OR TORQUE-ARM WITH SPLINED ANTIROLL BAR REAR SUSPENSION	\$14,989-UP
----------	---	-------------

### ■ gStreet Suspension Packages

7780	GSTREET CHASSIS STEEL SPINDLE A-ARM FRONT SUSPENSION INCLUDES STEEL FRONT SPINDLES, G-MACHINE UPPER AND LOWER CONTROL ARMS, POWER RACK AND PINION WITH BUMPSTEER ADJUSTABLE TIERODS, SPLINED ANTIROLL BAR, VARISHOCK COIL-OVERS WITH SPRINGS. OPTIONAL DISC BRAKES	\$4,340-UP
7781	GSTREET CHASSIS BILLET UPRIGHT A-ARM FRONT SUSPENSION INCLUDES BILLET ALUMINUM FRONT SPINDLES, WIDE-TRAC BILLET UPRIGHT UPPER AND LOWER CONTROL ARMS, POWER RACK AND PINION WITH BUMPSTEER ADJUSTABLE TIERODS, SPLINED ANTIROLL BAR, VARISHOCK COIL-OVERS WITH SPRINGS. OPTIONAL DISC BRAKES	6,396-UP
7790	GSTREET CHASSIS 4-LINK SUSPENSION INCLUDES CANTED TUBULAR 4-LINK SUSPENSION, SPLINED ANTIROLL BARS, VARISHOCK COIL-OVERS, SPRINGS & BILLET SHOCK MOUNTS. OPTIONAL DISC BRAKES	2,359-UP
7791	GSTREET CHASSIS TORQUE-ARM SUSPENSION INCLUDES TORQUE ARM WITH TUBULAR LOWER CONTROL ARMS, WATTS LINK, SPLINED ANTIROLL BAR, VARISHOCK COIL-OVERS, SPRINGS & BILLET SHOCK MOUNTS. OPTIONAL DISC BRAKES	3,579-UP

### ■ PARTIAL OPTIONS LIST

GAS TANK	FUEL TANK TRUNK FILL WITH BILLET ALUMINUM AIRCRAFT CAP, WITHOUT KEY (5921-F10-T)
	FUEL TANK REMOTE FILL WITH TAILLIGHT PANEL MOUNTED BILLET ALUMINUM AIRCRAFT CAP, WITH KEY (5921-F10-R)
SHOCKS	SINGLE-ADJUSTABLE VARISHOCK COIL-OVERS (PAIR)
	DOUBLE-ADJUSTABLE VARISHOCK COIL-OVERS (PAIR)
	4-WAY ADJUSTABLE REMOTE-RESERVOIR VARISHOCK COIL-OVERS WITH RESERVOIR MOUNTS (PAIR)
REAREND	FAB9 DIRECT BOLT-IN HOUSING WITH LATE-BIG-FORD ENDS (84F10-F01)
	FAB9 DIRECT BOLT-IN FLOATER HOUSING WITH AXLES AND UNIT-HUB FLOATER (84F10-F0B)
	EXTRA STRENGTH HOUSINGS ARE AVAILABLE WITH 4130 STEEL CONSTRUCTION
BRAKES	14" 6-PISTON FRONT BILLET UPRIGHT RED OR BLACK CALIPERS (8377)
	15" 6-PISTON FRONT BILLET UPRIGHT RED OR BLACK CALIPERS (8378)
	14" DISC REAR FLOATER (8380)
	15" DISC REAR FLOATER (8381)
	PARKING BRAKE UPGRADE
ROLL BAR/ ROLL CAGE	THERMLOCK® PISTON CALIPERS WITH NICKEL FINISH (PAIR)
	REMOVABLE FORWARD STRUTS, MILD STEEL (PAIR) (7060-F1-M)
	REMOVABLE FORWARD STRUTS, 4130 (PAIR) (7060-F1-A)
	ROLL CAGE UPGRADE FROM ROLL BAR
	REMOVABLE SIDE DOOR BARS (PAIR)
	STAINLESS SPUD HARDWARE FOR SIDE DOOR BARS AND BACKBRACE

# Body Fixture

■ NEW PRODUCT

The Chassisworks fixture is designed to securely hold the vehicle body and provide open interior working space once the floor or other sheet metal areas have been removed. Adapter bracket sets allow the fixture to be used with multiple vehicle models. The fixture bolts to a common 2-post lift and the vehicle body is held at the A-pillar, B-pillar (door striker), and rear bumper mounts. Casters are optionally available for added mobility.



7957-BF-FRAME	BODY FIXTURE FRAME COMPONENTS, REQUIRES ASSEMBLY, INCLUDES PRECUT 4X4" BOX TUBES AND FRAME MOUNTS. REQUIRES OPTIONAL WHEEL KIT AND BODY ADAPTERS.	\$1,695.00
7957-BF-F10	BODY ADAPTERS '67-69 CAMARO, REQUIRES ASSEMBLY, INCLUDES BODY ADAPTERS FOR A-PILLAR DOOR HINGES, B-PILLAR DOOR STRIKER AND REAR BUMPER.	206.00
7957-BF-M10	BODY ADAPTERS '65-70 MUSTANG, REQUIRES ASSEMBLY, INCLUDES BODY ADAPTERS FOR A-PILLAR DOOR HINGES, B-PILLAR DOOR STRIKER AND REAR BUMPER.	206.00
NOTE	SPECIAL ORDER PARTS AND NOT RETURNABLE FOR ANY REASON	



A-pillar (hinge bosses) body adapter



B-pillar (door striker) body adapter



Rear bumper body adapter

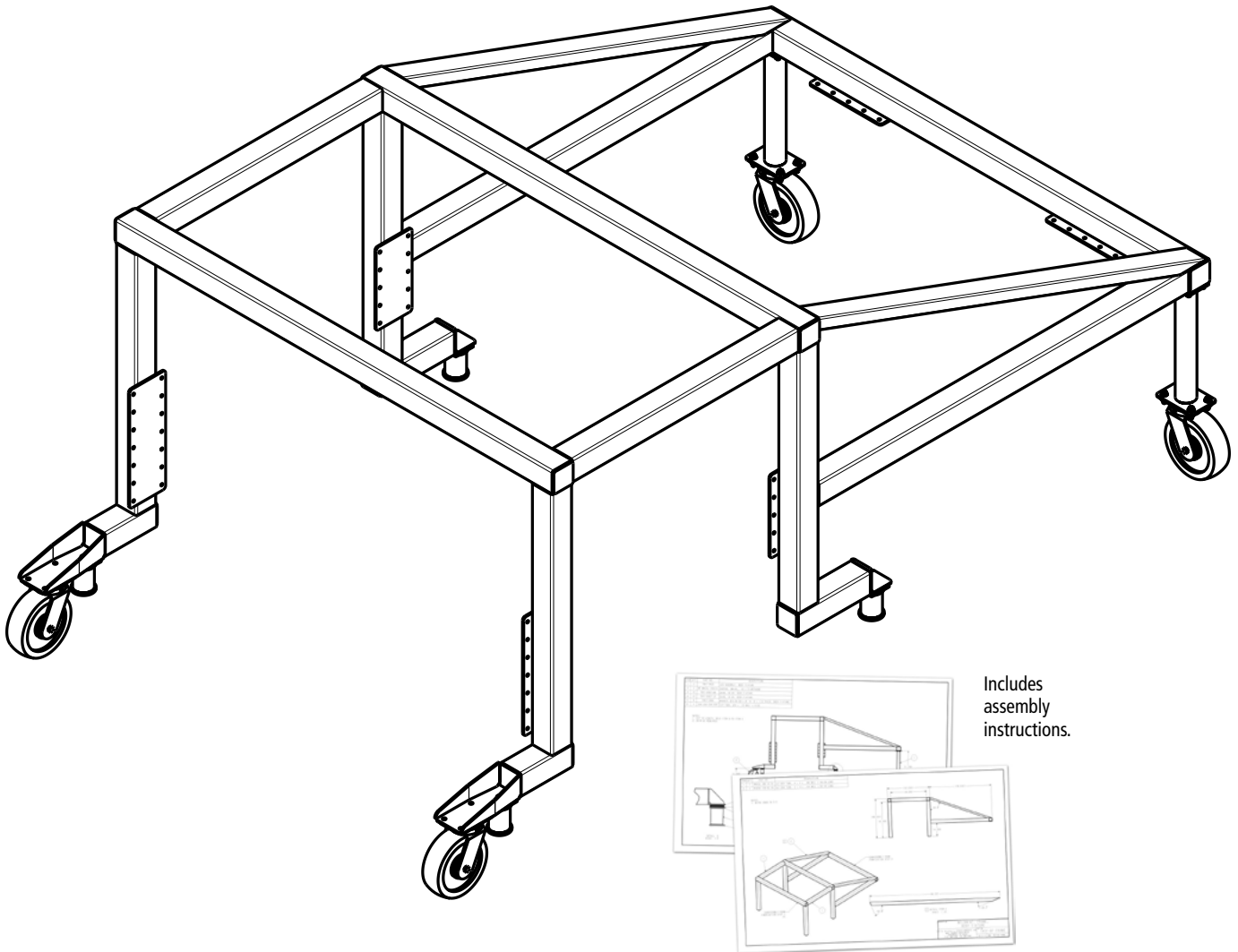

## ■ Wheel Set

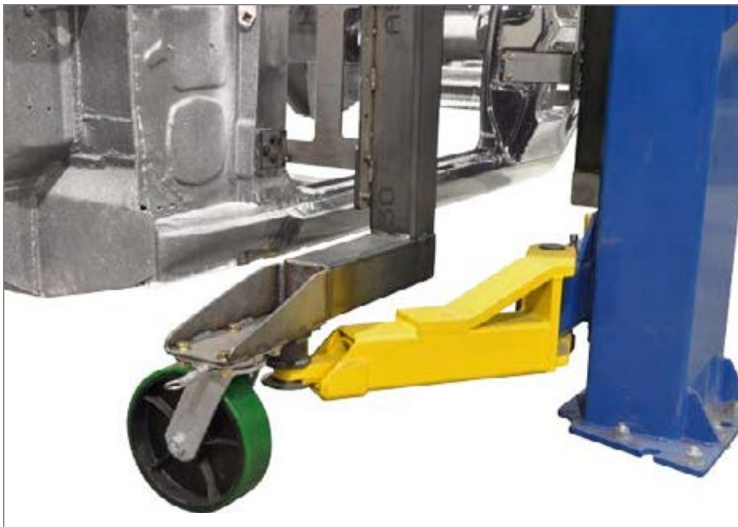

Front caster



Rear caster with extended fixture legs

7957-BF-WHEELS WHEEL SET FOR BODY FIXTURE FRAME, REQUIRES ASSEMBLY,  
INCLUDES FOUR CASTERS AND REAR FRAME LEGS \$1,069.00

NOTE SPECIAL ORDER PARTS AND NOT RETURNABLE FOR ANY REASON

# Body Cart

■ NEW PRODUCT



- **Sturdy 2x4" boxed steel tubing**
- **Exterior raised lip prevents body shifting**
- **Tie-down loop at each corner**
- **Heavy-duty casters included**
- **Welding required for assembly**
- **Ships as unassembled kit via small package carrier**

7957-CART	BODY CART COMPONENTS, UNASSEMBLED - INCLUDES PRECUT 2X4" BOX TUBES, BRACKETS, MOUNTS AND CASTERS.	\$539.00
NOTE	SPECIAL ORDER PARTS AND NOT RETURNABLE FOR ANY REASON	



# '67-69 Camaro gStreet Front Strut

■ NEW PRODUCT

Adding tubular struts between the factory upper firewall area and subframe triangulates the front clip, virtually eliminating chassis deflection forward of the firewall. To ensure a structurally secure mount, reinforcement plates and mounting tabs weld directly to the '67-69 Camaro firewall at the fender mount, the most rigid part of the firewall. The lower end of the support strut utilizes Chassisworks' exclusive bolt-together Gemini connector system. Installation of the strut and mounts requires minor trimming and welding for individual fit, but can later be unbolted to facilitate regular maintenance or subframe removal.

■ Fits OEM or g-Machine subframe



Optional hardware

7060-F1-A	'67-69 CAMARO - FRONT SUPPORT STRUTS, 4130, 1-5/8 X .083"	\$695.00
7060-F1-M	'67-69 CAMARO - FRONT SUPPORT STRUTS, MILD STEEL, 1-5/8 X .134"	489.00
7060-F2-M	'70-81 CAMARO - FRONT SUPPORT STRUTS, MILD STEEL, 1-5/8 X .134"	489.00
5918-126	SPUD MOUNTING HARDWARE, POLISHED STAINLESS	123.00



## ■ Gemini Connector System

Our in-house-engineered Gemini system is used to connect the strut to the subframe, enabling an easy-to-assemble, precision slip-fit joint that is substantially stronger than a welded joint.



**Frame Gemini Connector** welds easily to front frame rail.



**Firewall Mount Plate** shown with standard bolt.



**Polished Spud Bolt** shown at forward strut firewall mount.

# gStreet Exact-Fit Roll Cage

■ NEW PRODUCT

High-clearance cage sides, windshield brace, and rear struts makes our Exact-Fit roll cage an excellent choice for pro-touring performance applications to add a level of protection and increase chassis rigidity. Cages are mandrel bent in a variety of steel tubing types, including 1-5/8 x .134" mild-steel, 1-5/8 x .083" 4130, 1-3/4 x .134" mild-steel, and SCCA-compliant 1-3/4 x .125" DOM. The removable back brace with billet clevis ends comes standard. Door bars are included and can be installed at a 'street style', hip-height position for easier

entry and exit from the vehicle, or positioned at a higher 'race style' position for increased driver protection. Optionally available hardware permits removal of door bars when greater access is required. Spring-loaded faspins are standard removable bar hardware, with push-button L-handle locking pins and polished-stainless spud bolts offered as an upgrade option.

- '67-69 Camaro/Firebird
- '67-70 Mustang



- Cages Available In...
- 1-5/8" x .134" Mild Steel
- 1-5/8" x .083" 4130
- 1-3/4" x .134" Mild Steel
- 1-3/4" x .125" DOM

## Features/Benefits:

- Significantly increases chassis rigidity
- Maximizes interior space using multiple CNC compound bend angles
- Expert cage fabrication quality and fit with off-the-shelf convenience and availability
- Removable back brace included
- Optionally, door bars can be converted to removable
- Removable Hardware Styles: standard Faspins, quick-release L-handle pins, or polished-stainless spud bolts

## ■ Swing-Out Clevis Sets

Dual-purpose design makes a roll-cage side bar or back brace fully removable — or, simply swing it out for easy entry! In gStreet applications, clevis sets are provided for the driver's and passenger's cage-side bars, and for the main-hoop back brace. Clevis tube adapters match the specific ID and OD the selected cage or roll bar. Swing-out side bars are NHRA-accepted.

## ■ Safety Notes – gStreet Roll Cage/Bar

For safety purposes, roll-cage padding must be applied along any areas of the cage that occupants may come into contact with. Due to the additional cage-side and rear-strut bends, and removable door bars and back brace the g-Machine cages are not intended for competitive motorsports. Our competition series roll-cages are designed for ultimate strength and safety, and are better suited for serious competitive applications.

# gStreet Exact-Fit Roll Cage

■ NEW PRODUCT

## ■ SIDE BAR MOUNTING OPTIONS



**Street Style** - Lower hip-height bars provide greater vehicle access and can be made removable with optional faspins, quick-release L-handle pins, or spud bolts.



**Race Style** - Higher mounted bars provide greater protection and can be made removable with optional faspins, quick-release L-handle pins, or spud bolts.

## ■ REMOVABLE HARDWARE OPTIONS



**Standard Faspins** with spring-loaded ball lock.



**Polished Spud Bolt** shown at lower side bar clevis.



**Quick-Release L-Handle Pins** side bar and back brace clevis.

## ■ PRICING - Exact-Fit Roll Cages

7052-F10	'67-69 CAMARO, 1-5/8 X .134", ERW MILD STEEL	\$1,095.00
7053-F10	'67-69 CAMARO, 1-5/8 X .083", 4130 STEEL	1,695.00
7054-F10	'67-69 CAMARO, 1-3/4 X .134", ERW MILD STEEL	1,095.00
7055-F10	'67-69 CAMARO, 1-3/4 X .125", DOM MILD STEEL	1,695.00
7052-M20	'67-68 MUSTANG, 1-5/8 X .134", ERW MILD STEEL	1,095.00*
7053-M20	'67-68 MUSTANG, 1-5/8 X .083", 4130 STEEL	1,695.00*
7054-M20	'67-68 MUSTANG, 1-3/4 X .134", ERW MILD STEEL	1,095.00*
7055-M20	'67-68 MUSTANG, 1-3/4 X .125", DOM MILD STEEL	1,695.00*
7052-M30	'69-70 MUSTANG, 1-5/8 X .134", ERW MILD STEEL	1,095.00*
7053-M30	'69-70 MUSTANG, 1-5/8 X .083", 4130 STEEL	1,695.00*
7054-M30	'69-70 MUSTANG, 1-3/4 X .134", ERW MILD STEEL	1,095.00*
7055-M30	'69-70 MUSTANG, 1-3/4 X .125", DOM MILD STEEL	1,695.00*
NOTES	*INTRODUCTORY PRICING FOR MUSTANG CHASSIS	

## ■ OPTIONS - Exact-Fit Roll Cages

CAGE SIDE OPTIONS	IN FRONT OF DASHBOARD	INCLUDED
	THROUGH DASHBOARD	ADD 100.00
SIDE BAR OPTIONS	WELD-IN SIDE BARS	INCLUDED
	REMOVABLE SIDE BARS SWINGOUT	ADD 238.00
	REMOVABLE SIDE BARS, QUICK LOCK L-HANDLE	ADD 438.00
	REMOVABLE SIDE BARS WITH STAINLESS SPUDS	ADD 476.00
REAR STRUT OPTIONS	ATTACHES TO GSTREET FRAME	INCLUDED
	ATTACHES TO OEM TRUNK FLOOR	INCLUDED
	ATTACHES TO DSE 4-LINK COIL-OVER CROSSMEMBER	ADD 50.00
BACK BRACE OPTIONS	STANDARD BOLT-IN ATTACHMENT	INCLUDED
	PUSH BUTTON QUICK LOCK L-HANDLE	ADD 100.00
	STAINLESS SPUDS	ADD 119.00



# gStreet Exact-Fit Roll Cage

■ NEW PRODUCT

Featuring 1-3/4 x .134", mild-steel construction and high-clearance rear struts, our Exact-Fit roll bar is an excellent street-car-friendly choice. A removable back brace is included for easier access to the rear seat area. The low hip-height, weld-in side bars allow easy access as well as increase rigidity of the Camaro unibody structure. Optionally

available hardware permits easy removal of the side bars.

Removable hardware options include: spring-loaded faspins, quick-release ball-lock L-handle pins, or polished stainless-steel spud bolts.

- '67-69 Camaro/Firebird
- '67-70 Mustang

## ■ ROLL BAR (NO SIDE BARS)

### ■ Back Brace Hardware Options

- Standard Hex Bolts
- Quick Lock L-Handles
- Stainless Spuds

### ■ Rear Strut Options

- For gStreet Frame
- For OEM Trunk Floor
- For DSE 4-Link Shock Crossmember



## ■ ROLL BAR WITH SIDE BARS

### ■ Back Brace Options (see above)

### ■ Rear Strut Options (see above)

### ■ Side Bar Options

- Weld-In Bars
- Standard Hex Bolts, Removable
- Quick Lock L-Handles, Removable
- Stainless Spuds, Removable



# gStreet Exact-Fit Roll Bar

NEW PRODUCT

## Removable Hardware Upgrades



### Quick-Release L-Handle Pin

Push-button ball-lock pin available for quick removal of door bar and back brace.



### Polished Spud Bolt

Stainless-steel male and female custom fasteners with no snag beveled head.



### Gemini Connector - OPTION

The optional removable side bar system uses our in-house-engineered Gemini connector to securely fasten the door bar strut to the subframe with no decrease in available room for the driver's feet. The Gemini connector is an easy-to-assemble, precision slip-fit joint that is substantially stronger than a welded joint.



## gStreet Exact-Fit Roll Bar (no side bars)

INCLUDES MILD STEEL, 1-3/4 X .134"-WALL MAIN HOOP, BACK BRACE, REAR STRUTS, AND FLOOR PLATES

7050-F10	'67-69 CAMARO	\$695.00
7050-M20	'67-68 MUSTANG	695.00*
7050-M30	'69-70 MUSTANG	695.00*
REMOVABLE BACK-BRACE OPTIONS	STANDARD HEX BOLT HARDWARE	INCLUDED
	PUSH BUTTON L-HANDLE HARDWARE	ADD 100.00
	POLISHED STAINLESS SPUD HARDWARE	ADD 119.00
REAR STRUT ATTACHMENT OPTIONS	FOR GSTREET FRAME	INCLUDED
	FOR OEM TRUNK FLOOR	INCLUDED
	FOR DSE 4-LINK SHOCK CROSSMEMBER	ADD 50.00



## gStreet Exact-Fit Roll Bar with Side Bars

INCLUDES MILD STEEL, 1-3/4 X .134"-WALL MAIN HOOP, SIDE BARS, BACK BRACE, REAR STRUTS, AND FLOOR PLATES

7051-F10	'67-69 CAMARO	\$795.00
7051-M20	'67-68 MUSTANG	795.00*
7051-M30	'69-70 MUSTANG	795.00*
SIDE BAR OPTIONS	WELD-IN SIDE BARS, NON-REMOVABLE	INCLUDED
	BOLT-IN, REMOVABLE BARS	200.00
	PUSH BUTTON L-HANDLE, REMOVABLE BARS	300.00
	POLISHED STAINLESS SPUD, REMOVABLE BARS	438.00
REMOVABLE BACK-BRACE OPTIONS	STANDARD HEX BOLT HARDWARE	INCLUDED
	PUSH BUTTON L-HANDLE HARDWARE	ADD 100.00
	POLISHED STAINLESS SPUD HARDWARE	ADD 119.00
REAR STRUT ATTACHMENT OPTIONS	FOR GSTREET FRAME	INCLUDED
	FOR OEM TRUNK FLOOR	INCLUDED
	FOR DSE 4-LINK SHOCK CROSSMEMBER	ADD 50.00



# gStreet Wide Track Arms

## ■ gStreet A-Arms

Chassisworks' gStreet A-arms are designed for ultimate-performance-handling vehicles using our g-Machine or Street-Machine crossmember system with VariShock coil-over or air suspension. Polymer pivot bearings and cross-braced tubular design provide sharp handling and effective suspension tuning, thanks to minimal resistance and deflection. Mandrel-bent, 1" and 1-1/4" main tubes with 7/8" and 1" cross braces create an extremely rigid, triangulated arm durable enough for regular track use. With the aid of a fixture, tubes are seated into recessed faces along the billet receiver or balljoint housing to form a high-strength, interlocking, TIG-welded joint.

**Wide Track Arms** - The gStreet A-arm and spindle system utilizes the same chassis mounts as our Street-Machine and g-Machine arms. Arm length is increased 1-1/2" to provide more gradual geometry changes throughout suspension travel. To the skilled driver this means more direct tire feedback and more linear response to steering and braking inputs under various dynamic conditions. Specific geometry changes include vastly reduced scrub radius, improved camber gain, and increased caster (8.5 degrees at center of adjustment) without altering the wheelbase.



### Upper Arm

- Low-friction polymer pivot bearing
- Caster/camber adjustment coupler
- 1"-diameter tubular arm body
- 7/8"-diameter cross brace
- Billet-steel A-arm pivot stud receiver
- Tension-adjustable spherical pivot (in upright)

### Lower Arm

- Tension-adjustable spherical pivot (in arm)
- Billet pivot housing with integrated gussets
- 1-1/4"-diameter tubular arm body
- 1"-diameter cross brace
- Low-friction polymer pivot bearing
- Minimum 18"-19" wheel required, depending upon wheel style

# gStreet Wide Track Arms

## ■ gStreet Upper A-Arms

6157 gSTREET UPPER ADJUSTABLE A-ARMS,  
BLACK MILD-STEEL ARM



**Upper Arm Pivot** - Housed within the billet upright, the tension-adjustable pivot assembly can be tightened to compensate for wear.



## ■ gStreet Lower A-Arms

6156 gSTREET LOWER A-ARMS, BLACK MILD-STEEL ARM, PLATED MILD-STEEL AND STAINLESS-STEEL HARDWARE



**Lower Arm Pivot** - Similar to the upper arm, the pivot is adjustable for tension to ensure zero free play with minimal resistance; fully rebuildable.

## ■ BILLET-ALUMINUM UNIT-BEARING UPRIGHT WITH GSTREET LARGE-ROTOR DISC BRAKE KIT



### ■ Billet-Aluminum Upright

Engineered to work with Chassisworks bolt-on clips and 4x2" weld-in suspension crossmembers, the billet-aluminum unit-bearing upright again raises the pro-touring bar. The lightweight upright features a heavy-duty, sealed unit bearing that is both larger in diameter and considerably more reliable than the commonly used and frequently replaced Corvette components.

### ■ Bump-Steer Kit

The latest innovation from the mind of Chris Alston is our infinitely adjustable bump-steer kit with Teflon®-lined 4130 rod end. Utilizing a unique 3/4" threaded stud with locknut, the height of the pivot point can be quickly adjusted without disassembly or hasseling with shim stacks. No other adjustment mechanism is this precise.

### ■ Disc Brake Kit

Continuing down the path of bigger wheels and tires leading to better performance, Chassisworks offers a specially developed brake kit, featuring 14" or massive 15" x 1.25" rotors with radial-mount, Wilwood or Baer, 6-piston calipers in a variety of finishes and optional pad compounds.

### Features/Benefits:

- Lightweight billet-aluminum upright with stainless-steel tapered balljoint inserts
- Maintenance friendly, heavy-duty unit-bearing; larger and more reliable than Corvette bearing
- Unique threaded bump-steer adjustment stud with Teflon®-lined 4130 rod end
- Massive 14" and 15" x 1-1/4"-wide vented brake rotors
- Radial-mount 6-piston Wilwood calipers with optional Thermlock™ heat-barrier pistons
- Lightweight billet-aluminum hat



**BILLET-ALUMINUM UNIT-BEARING UPRIGHT**

1. Heat-treated, corrosion resistant pivot stud
2. Aluminum cap permits access to joint tension adjustment
3. Lightweight billet-aluminum upright
4. Integrated caliper bracket mounts
5. Unit-bearing hub mounting hardware
6. Steering arm cross bolt

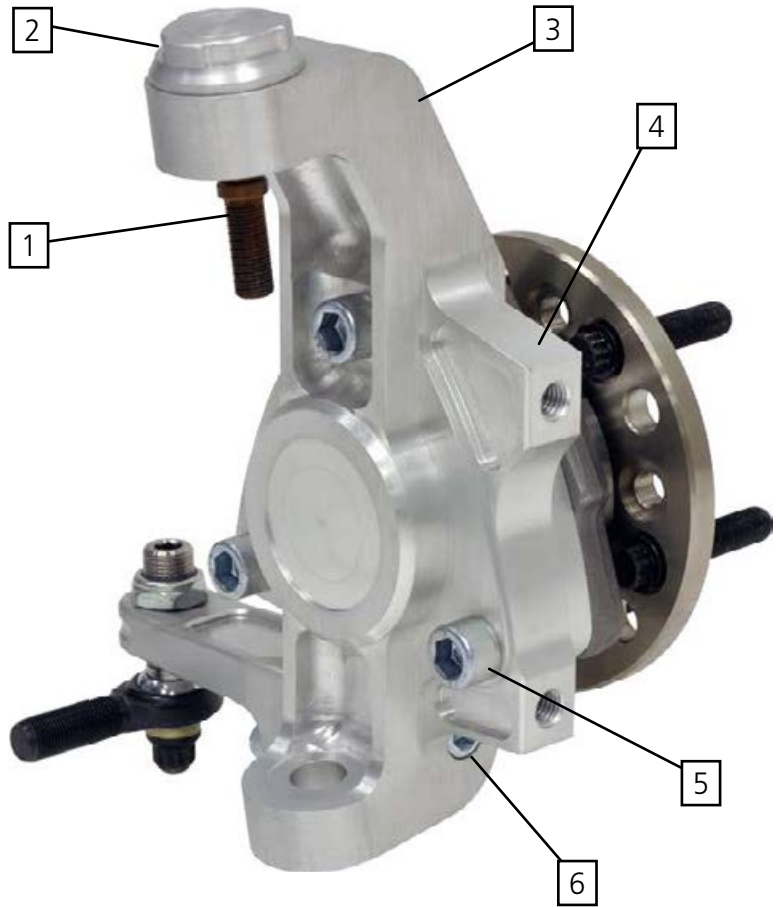

7. Bolt Circles: 5 on 4-3/4", 5 on 4-1/2" with 1/2-20 x 2-1/4"-long wheel studs
8. Cross-bolted steering arm with locating pin feature
9. Infinitely adjustable bumpsteer outer tie-rod
10. Heavy-duty, sealed, tapered roller bearing hub assembly with precision bearings

5737-SM1-1	UPRIGHT (5 ON 4-1/2" BOLT CIRCLE) RODEND ARM GM CHASSISWORKS CLIPS, ALUMINUM BODY WITH UNIT-BEARING SPINDLE INCLUDES STEERING ARM WITH THREADED BORE FOR 5/8" RODEND-STYLE TIEROD END	\$1,998.00
5737-SM1-2	UPRIGHT (5 ON 4-3/4" BOLT CIRCLE) RODEND ARM GM CHASSISWORKS CLIPS, ALUMINUM BODY WITH UNIT-BEARING SPINDLE INCLUDES STEERING ARM WITH THREADED BORE FOR 5/8" RODEND-STYLE TIEROD END	1,998.00
NOTE	MINIMUM RIM SIZE 18" DIAMETER, DEPENDING ON WIDTH, TO ACCOMMODATE BRAKE ROTOR.	

## INFINITE ADJUST BUMP-STEER KIT



Threaded adjuster allows infinite adjustment without disassembly or the hassle of shim stacks.

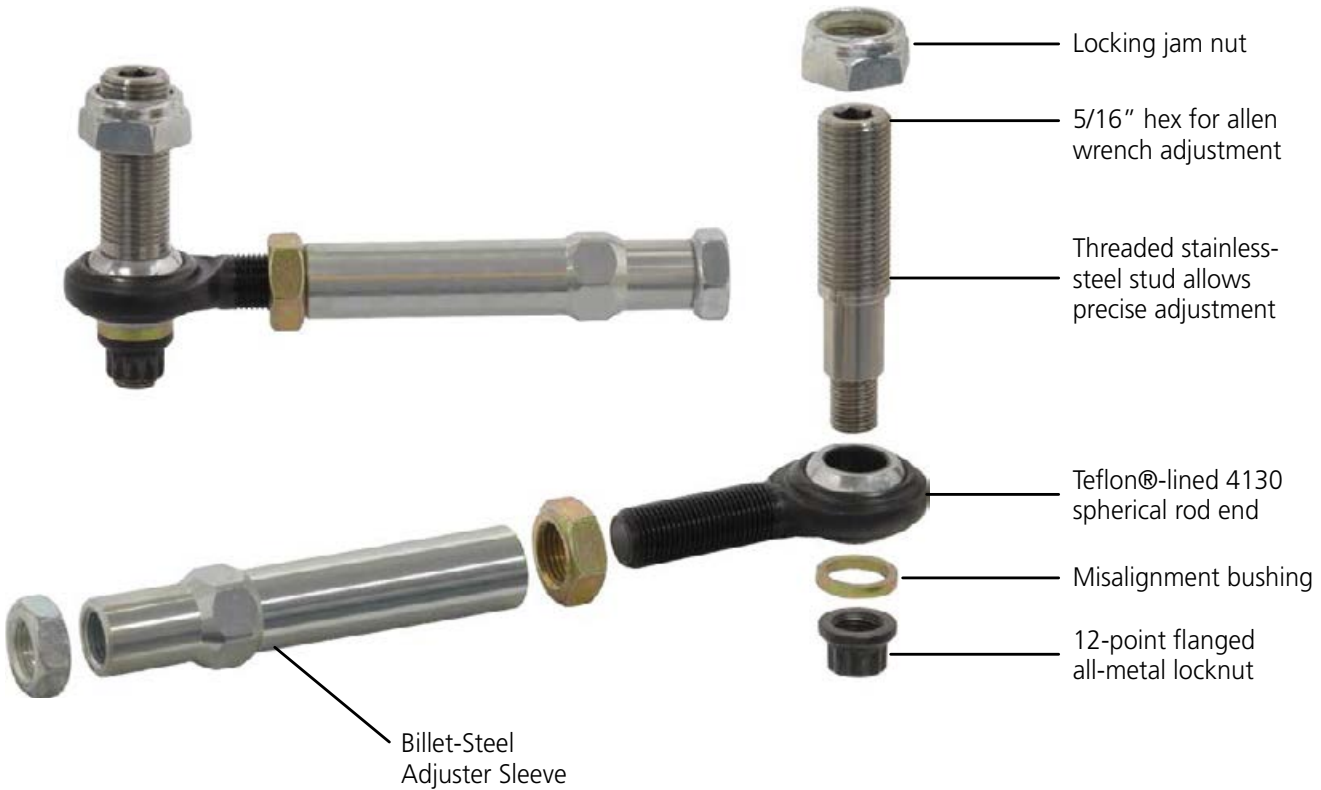

5736-75-56 THREADED BUMPSTEER ADJUSTER AND ROD END TIEROD WITH BILLET ADJUSTING SLEEVE. FOR USE WITH CHASSISWORKS BILLET UPRIGHTS WITH 3/4-16 THREAD STEERING ARMS

\$236.00

# gStreet 14" and 15" Front Brake Kits

■ NEW PRODUCT

gStreet brake kits for Chassisworks billet upright feature rear-mounted, radial mount, six-piston calipers and 14" or 15" directional-vented rotors with billet aluminum hats. The bolt-together hat-rotor assembly allows worn or damaged components to be replaced easily and economically. Enhanced-friction ceramic-formula brake pads provide smooth engagement, long service life, low noise, and light brake-dust levels for performance driving applications; performance specific pads also available for autocross and road race applications. The kit is designed for use with Chassisworks' exclusive gStreet billet-aluminum uprights for vehicles equipped with Chassisworks' bolt-on front clips or weld-in 4 x 2" crossmembers, clips, and frames. Fourteen- and fifteen-inch rotors require 18" and 19" wheels respectively. Includes SRP drilled (black e-coated) rotors, Wilwood calipers (black, red or nickel finish) with optional Thermlock™ heat-barrier pistons, or Baer one-piece calipers.



## Features/Benefits:

- 14" and 15" cross-drilled and vented rotors with black e-coat finish
- Wilwood Aero6 6-piston, radial-mount calipers; black, red or nickel finish with Thermlock® pistons
- Optional Wilwood brake pad compounds
- Baer 6S 6-piston, radial-mount calipers

8377	GSTREET 14" SRP ROTORS, 6-PISTON AERO6 CALIPERS (BLACK OR RED)	\$2,255.00
8378	GSTREET 15" SRP ROTORS, 6-PISTON AERO6 CALIPERS (BLACK OR RED)	2,461.00
OPTIONS	BLACK OR RED POWDER-COAT FINISH CALIPERS	INCLUDED
	NICKEL-COATED CALIPERS WITH THERMLOCK™ HEAT-BARRIER PISTONS	UPGRADE
	STREET AND PERFORMANCE SMART PAD (LOW NOISE, LIGHT DUST)	INCLUDED
	AUTOCROSS SPECIFIC PAD COMPOUND	UPGRADE
	ROAD RACE SPECIFIC PAD COMPOUND	UPGRADE
NOTES	FITS gSTREET BILLET-ALUMINUM UPRIGHT FOR CHASSISWORKS CROSSMEMBER SYSTEMS ONLY.	

# gStreet 14" and 15" Front Brake Kits

■ NEW PRODUCT

## ■ WILWOOD AERO6 6-PISTON CALIPERS

The Aero6 six-piston caliper delivers heavy duty stopping power for the road or track. The caliper incorporates race technology into a body design with widespread adaptability. Radial mounting and a rotor diameter range from 14.00" to 15.00" give this caliper the versatility necessary to suit all types of heavy weight braking requirements. Available in black or red powder coat finish, or optional nickel finish with Thermlock™ heat-barrier pistons.



## ■ Wilwood ThermLock® Pistons (Nickel-coated caliper only)

Thermlock® pistons block heat transfer from the pads and reduce temperatures in the caliper, fluid, and seals by up to 25% over standard stainless steel pistons. These are the go-to calipers for all types sustained hard braking on a wide range of autocross, rally and road course applications.



## ■ Brake Pad Compounds

The standard street and performance pads included with the gStreet brake kits are suitable for everyday use and occasional performance driving. We recommend upgrading pad compounds for regular autocross and road race use.



## Brake Pad Compounds

STREET/PERFORMANCE	LOW NOISE AND DUST LEVELS
AUTOCROSS	AGGRESSIVE GRIP AT AMBIENT TEMPERATURE
ROAD RACE	AGGRESSIVE GRIP WITH HIGHER TEMPERATURE RANGE

## ■ BAER 6S 6-PISTON FORGED-MONOBLOCK CALIPERS

The Baer 6S is a forged-monoblock 6-piston caliper for pro-touring projects that need race car performance. To maximize strength the 6S caliper is machined from a single aluminum-alloy forging and utilizes an external crossover tube. Calipers feature stainless steel pistons, noise suppression springs, and staggered piston sizes to minimize pad wear. Available in red, black or silver powder-coat finish.



# gStreet 14" and 15" Front Brake Kits

■ NEW PRODUCT

## ■ SRP DRILLED PERFORMANCE ROTORS

gStreet brake kits feature directional-vaned, cross-drilled rotors measuring 14" or 15" x 1.25"-wide. To create more surface area and maximize cooling, individual passages are cast internally into the rotor. Air passages or vanes are directional and curved for increased airflow over standard straight vented rotor designs. The slotted surface and cross-drilled holes improve pad-to-rotor contact by wiping the pad clean and allowing brake dust and gases to be easily exhausted. Rotors are black e-coated to prevent rust on internal and external rotor surfaces.



■ 14" and 15" rotors for big-tire, high-performance Pro-Touring builds

## ■ gStreet 15"



15 x 1.25"

## ■ gStreet 14"



14 x 1.25"



CHASSISWORKS  
**Chassisworks**  
THE HOME OF HIGHER TECHNOLOGY

**Any way you slice it...  
that's a BIG ASS ROTOR!**

The new 15" front brake kit for Chassisworks gStreet front clip systems.

# g-Machine-System Rack and Pinions

## ■ g-Machine Power Rack and Pinion

The g-Machine front-steer power rack and pinion provides responsive steering with excellent driver feedback as a direct bolt-on for Chassisworks g-Machine crossmember systems. To increase durability, performance, and reduce deflection, the rack body, control servo, and hard lines are constructed from steel. Hard lines are routed tightly against the rack body and low-profile, rotatable banjo fittings are used exclusively at the control servo to better package the rack for installation.

Note: Camaro uses 6140-245-X, Mustang uses 6140-235-X.

- Front-steer power rack and pinion
- Direct bolt-on for g-Machine crossmember systems; includes Camaro and Mustang gStreet chassis
- Rotatable within mounts to aid steering-shaft clearance
- Available in left- and right-hand drive versions
- Black powder-coat or chrome finish

■ **Right-Hand-Drive Racks Available**



## ■ Power Rack-and-Pinion Billet Mounts

Our unique clamping installation method enables the rack to be rotated within its mounts to adjust steering-shaft clearance and universal-joint angles. The solid billet aluminum base-and-clamp assembly uses our slot-tab positioning method for perfect alignment with the factory-welded g-Machine crossmember. Once tightened into mating grooves at the widest portion of the rack body, the deflection-free mount completely prevents the rack from shifting. Mount sets include clamp hardware and are available in silver-anodized satin or polished finishes.



## ■ Rack-and-Pinion Specifications

FEATURE	SPECIFICATION/DIMENSION
RACK TRAVEL	3 TURNS LOCK TO LOCK, 1.8" PER TURN, 5.375" TOTAL TRAVEL
INNER-TIE-ROD THREAD	9/16-18 RH MALE
INNER-TIE-ROD LENGTH <sup>1</sup>	10.135"
TIE-ROD ASSEMBLY LENGTH <sup>2</sup>	13.283"
INPUT SHAFT	16.8-MM DD
HYDRAULIC FITTINGS	-6 AN (PRESSURE AND RETURN)
RECOMMENDED PUMP RATE	1.0 - 1.5 GPM (3.8 - 5.7 LPM)
NOTES	1 - MEASURED FROM TIE-ROD PIVOT CENTER TO THREADED SHAFT END 2 - MEASURED FROM CENTER OF INNER- AND OUTER-TIE-ROD PIVOTS

6140-245-1	G-MACHINE POWER RACK, 24.5" LEFT-HAND-DRIVE, BLACK	695.00
6140-245-2	G-MACHINE POWER RACK, 24.5" LEFT-HAND-DRIVE, CHROME	825.00
6140-245-1RIGHT	G-MACHINE POWER RACK, 24.5" RIGHT-HAND-DRIVE, BLACK	795.00
6140-245-2RIGHT	G-MACHINE POWER RACK, 24.5" RIGHT-HAND-DRIVE, CHROME	923.00
6139-245-1	BILLET CLAMP SET FOR 24.5" RACK, SATIN FINISH	165.00

# g-Machine-System Power Steering Pump

Built upon a lightweight, aluminum-bodied power-steering pump, Chassisworks g-Machine system offers versatility in a variety of engine and performance applications. The GM-style pump is a direct bolt-on for LS-series engines and can be easily installed on small-block or big-block Chevy engines

using the included billet mounting bracket and spacers. Pumps are available with a compact integrated plastic reservoir or with a remote-mounted, polished billet-aluminum reservoir. V-belt or serpentine polished pulleys can also be selected with either pump style.

## ■ Remote-Reservoir Power-Steering Pump Kit

6138	REMOTE-RESERVIOR POWER STEERING PUMP - INCLUDES PUMP WITH PULLEY, ENGINE MOUNTING BRACKET AND BILLET REMOTE RESERVIOR	\$459.00
OPTIONS	SMALL-BLOCK CHEVY OR BIG-BLOCK CHEVY MOUNT	INCLUDED
	6 X 6" UNIVERSAL MOUNTING BRACKET BLANK (REQUIRES MACHINING)	INCLUDED
	5" V-BELT PULLEY	INCLUDED
	4-7/8" SERPENTINE PULLEY	ADD 20.00
	STAINLESS-TEFLON® HOSE KIT	ADD 275.00
5720-001	FITTING SET, 16MM AND 18MM O-RING TO -6 AN	26.00



5720-001 - O-ring to -6 AN adaters for use with steering boxes



## ■ Integrated-Reservoir Power-Steering Pump Kit

6137	INTEGRATED-RESERVOIR POWER STEERING PUMP - INCLUDES INTEGRAL PLASTIC RESERVIOR PUMP WITH PULLEY AND ENGINE MOUNTING BRACKET.	\$385.00
OPTIONS	SMALL-BLOCK CHEVY OR BIG-BLOCK CHEVY MOUNT	INCLUDED
	6 X 6" UNIVERSAL MOUNTING BRACKET BLANK (REQUIRES MACHINING)	INCLUDED
	5" V-BELT PULLEY	INCLUDED
	4-7/8" SERPENTINE PULLEY	ADD 20.00
	STAINLESS-TEFLON® HOSE KIT	ADD 165.00
5720-001	FITTING SET, 16MM AND 18MM O-RING TO -6 AN	26.00



5720-001 - O-ring to -6 AN adaters for use with steering boxes



# Billet Gun-Drilled Anti-Roll Bar

NEW PRODUCT

## Gun-Drilled Splined-End Anti-Roll

Our street/track performance gStreet anti-roll bar offers substantially increased stiffness and flatter cornering over our standard Street-Machine component. Kits are designed for Chassisworks g-Machine crossmember systems equipped with g-Machine A-arms. Anti-roll bar manufacturing begins with 1.25" OD alloy steel bar, which is then gun-drilled to significantly reduce weight. The billet lever arms feature multiple endlink mounting holes for a total of six different spring rates and are secured by a single-split splined collar clamp integrated into the arm. Teflon® race, spherical-bearing, end-link assemblies create deflection-free pivot points with minimal-resistance and enable the anti-roll bar's effects to be immediate, more linear, and predictable. End-link length is also adjustable to eliminate static preload and ensure balanced handling. Billet aluminum bearing housings mount the anti-roll bar to the factory-welded mounting blocks and are securely held by 3/8" socket-head bolts. Low-friction polymer bearings allow the bar to pivot freely without introducing off-axis free play. Anti-roll bars ship as complete kits with zinc-plated components and hardware.

## Features/Benefits:

- 1-1/4" -OD heat treated, alloy steel bar
- Billet-steel splined arms with multiple endlink positions
- Six-different stiffness settings
- Spherical bearing end links with Teflon lined races
- Billet-aluminum bearing housings
- Low-friction polymer bearings
- Zinc-plate or anodize finish

5735-SM32-12588	'67-68 MUSTANG GSTREET CLIP	\$599.00
5735-SM33-12588	'67-81 CAMARO GSTREET CLIPS	599.00

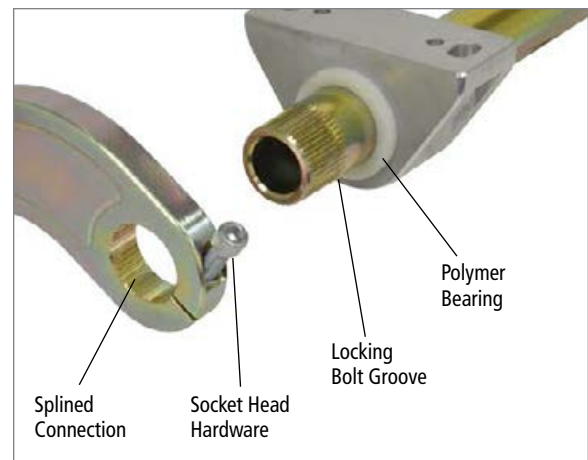
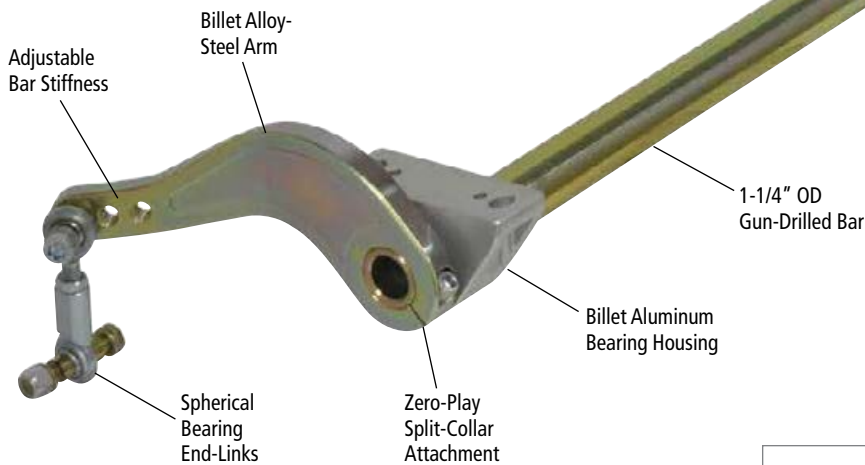

# Custom-Fit Canted 4-Bar Anti-Roll Bar

The newest innovation in rear-suspension control is Chassisworks' ball-end anti-roll bar with integrated frame-rail mounts. It has been designed specifically to provide maximum exhaust clearance by placing the anti-roll bar closely against the vehicle's under-body, with no bulky mounts placed along the frame rail. The key to our tucked-away installation are the threaded mounting sleeves integrated directly into each frame rail. Billet bushing housings screw in from the outside of each frame rail to capture the ball-ends of the bar with low-friction polymer bearings.

The anti-roll-bar assembly includes a 7/8" road-handling, heat-treated torsion bar with splined ends and billet aluminum arms. Each arm is machined with a single split to ease installation fit and to clamp down upon the spline when tightened. A socket-head fastener applies pressure to the spline, creating a play-free joint while also fitting into a groove machined at the end of the bar. This locking joint prevents the arms from sliding, even under the most extreme force. Billet arms are connected to the chassis mounts by adjustable-length end-link assemblies. Steel end-link tubes feature left- and right-hand threads and a 1/2" hex for quick adjustment during installation. Adjuster links feature a 3/8"-shank 4130-body rod end for the ultimate in strength.

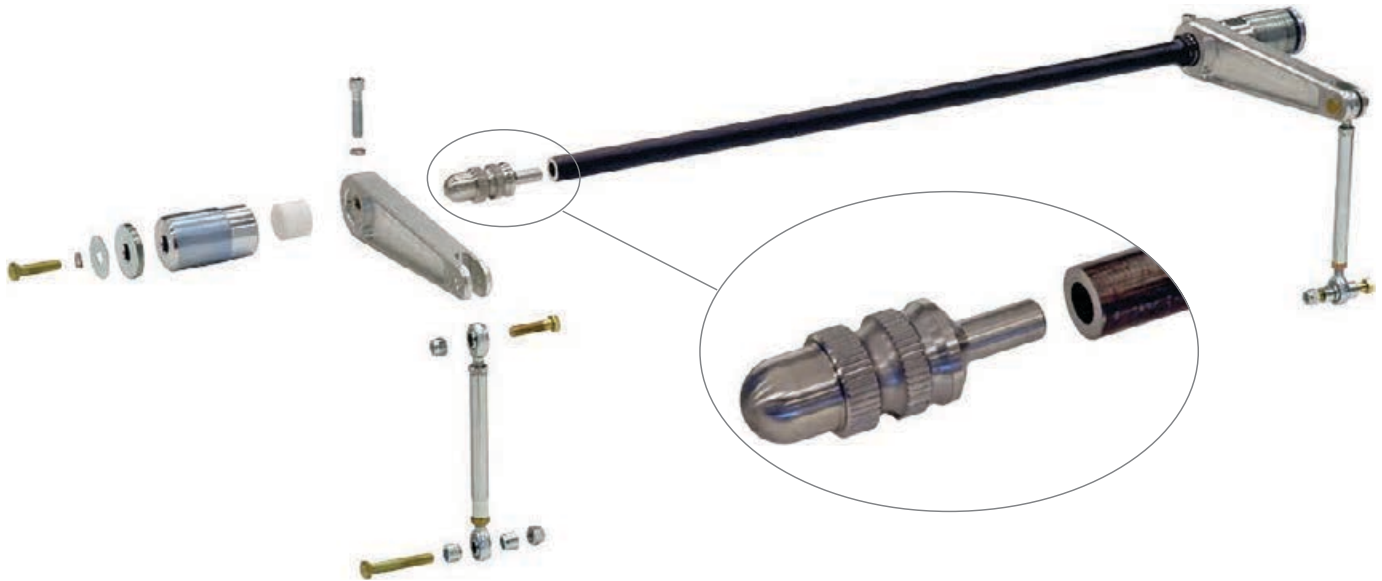

6259 7/8" -DIAMETER BALL-END ANTI-ROLL BAR FOR CANTED REAR SUSPENSION \$549.00

# 9" Third-Member Packages

## ■ ST Iron Truetrac Package (Up to 700 hp, Case - 26.70 lb)

The ST Iron package is a completely assembled Ford 9" third member shipped ready to install. Cases are constructed from high-grade nodular iron and feature a radial ribbed design providing more uniform support for the pinion and carrier bearings. The caps, also nodular iron, are designed with increased thickness for added strength and ring-gear stability. Third members are equipped with Truetrac worm-gear differentials, with proven acceleration performance in both strip and handling applications. A Daytona-style iron pinion support is included and features a larger than stock rear tapered pinion bearing and improved oil porting. Ring-and-pinion gear selections include: 3.50, 3.70, 3.89, 4.11, 4.30 and 4.57.

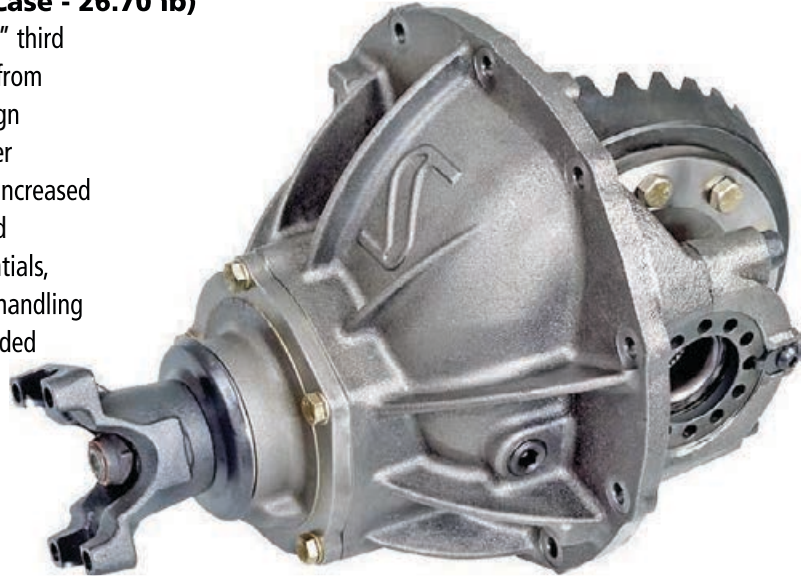

8520-112	ST IRON NODULAR CASE, 31-SPLINE TRUETRAC DIFFERENTIAL, 8620 GEAR SET WITH CHOICE OF RATIO (3.50-4.57), CHROME-MOLY 1350 YOKE, DAYTONA IRON PINION SUPPORT	\$1,525.00
8520-122	ST IRON NODULAR CASE, 35-SPLINE TRUETRAC DIFFERENTIAL, 8620 GEAR SET WITH CHOICE OF RATIO (3.50-4.57), CHROME-MOLY 1350 YOKE, DAYTONA IRON PINION SUPPORT	1,835.00

- ST Iron Case (Nodular Iron)
- Dayton Pinion Support
- 1350 Chrome-moly Yoke
- Truetrac Differential (31- or 35-spline)

## ■ Pro HD Aluminum Truetrac Package (Up to 1000 hp, Case - 31.50 lb)

The Pro HD package is a completely assembled Ford 9" third member shipped ready to install. Cases are constructed from 206-T4 heat treated aluminum and feature a radial ribbed design providing more uniform support for the pinion and carrier bearings. Billet aluminum caps are retained with 9/16" studs and are fully machined. The cap design provides the utmost support for the carrier bearings and significantly reduces ring gear deflection. Third members are equipped with Truetrac worm-gear differentials, with proven acceleration performance in both strip and handling applications. The billet aluminum pinion support has a unique oil channel that is machined 360 degrees into the support to maximize oil flow to the pinion bearings thru optimized porting holes, as well as a large slot milled into the front of the support to further boost oil circulation. Ring-and-pinion gear selections include: 3.50, 3.60, 3.70, 3.89, 4.11, 4.30, 4.57, 4.71 and 4.86.



8520-319	PRO HD ALUMINUM CASE, 31-SPLINE TRUETRAC DIFFERENTIAL, 8620 GEAR SET WITH CHOICE OF RATIO (3.50-4.57), CHROME-MOLY 1350 YOKE, BILLET ALUMINUM PINION SUPPORT	\$1,820.00
8520-329	PRO HD ALUMINUM CASE, 35-SPLINE TRUETRAC DIFFERENTIAL, 8620 GEAR SET WITH CHOICE OF RATIO (3.50-4.57), CHROME-MOLY 1350 YOKE, BILLET ALUMINUM PINION SUPPORT	2,130.00

- Pro HD Aluminum Thru-Bolt Case
- Billet Aluminum Pinion Support
- 1350 Chrome-moly Yoke
- Truetrac Differential (31- or 35-spline)

# Custom Axle Packages

We are proud to offer high-quality axle packages from the performance industry leader, Strange Engineering. Kits come with everything needed for a complete axle installation into your new aftermarket or existing factory housing and third member. Two series of axles are available. S-Series, induction-hardened axles are suitable for a wide variety of performance applications including street, strip or track use. For dedicated-drag-racing applications, the Thru-hardened, ProRace series can withstand power levels beyond 1000 horsepower. Allow 1-4 weeks for delivery.



## ■ Induction-Hardened Axles (S/S,ST)

Each axle begins as a SAE 1550 modified steel forging, which then undergoes spline hobbing and CNC machining to meet exact required specifications. To improve resistance against bending loads and wear, a post-machining process of electric-coil-induction hardening is performed. Induction hardening increases the hardness of the outer surface while maintaining a more-ductile axle core, necessary for reliable street use. Both S/S and S/T axles feature precisely machined, 1.5635" bearing and special radius ring seats. The press-fit radius ring minimizes stress concentrations along the bearing shoulder and improves axle-flange stability. Bolt-on, billet-aluminum brake registers are machined to size, based on your particular brake and wheel requirements.



### S/S 31-Spline Axles (up to 600 hp)

For street and handling performance applications, 31-spline S/S axles are recommended. S/S axles can be used with factory 2.891" - or aftermarket 3.0625" -bore cases with appropriate differential (posi-traction, torque-sensing, locker or spool).

### S/T 35-Spline Axles (up to 800 hp)

For street/strip applications, the S/T axles feature a larger, 1.50" -diameter, 35-spline end that is better suited for the extreme levels of torque during launches. Requires 3.250" -bore case with appropriate gear carrier (locker or spool only).

## ■ Wheel-Stud Options

There are two types of wheel studs available in a variety of lengths.

### Screw-In Studs (1/2")

The standard, 1/2" screw-in stud uses a headed fastener threaded through the axle flange from the back side. The wheel is centered by the raised "brake register" of the axle and driven by the lug-nut-contact surfaces. In the case of a tapered (acorn) lug nut, the driving surface is at the unsupported end of the wheel stud. Available lengths: 2", 3."



## ■ Axle-Package Pricing

Specific information regarding the vehicle application is required. Visit our Website or call to obtain technical data sheet with ordering requirements.



Includes: axles, radius rings, billet brake registers, bearings, wheel studs

S/S	31-SPLINE, 1/2" STUDS	\$415.00
	31-SPLINE, 5/8" STUDS	485.00
S/T	35-SPLINE, 1/2" STUDS	415.00
	35-SPLINE, 5/8" STUDS	485.00

## ■ FLOATER AXLE SYSTEM AND RADIAL-MOUNT CALIPER WITH DRUM-STYLE PARKING BRAKE SYSTEM

Today's top pro-touring vehicles often feature some of the largest section-width tires available matched with rapidly increasing levels of horsepower and torque. These drivetrain combos frequently push the reliability and safety limits of the standard flange-style axles that are common place on most muscle cars. Chassisworks solution to raising the reliability and safety limit is a complete floater-axle and brake system designed specifically for the leading-edge pro-touring market. This system features a tapered-roller unit-bearing; larger, stronger, and more reliable than the Corvette ZR1 bearing, which bolts to a specially designed housing end to remove all weight and bending load from the axles. The axle is left with the sole purpose of transferring torque to the wheels and can then be designed as

a simple axle shaft with splines at both ends. Axles are for 35-spline differentials for increased strength over 31-spline axles. To provide ample braking force for sometimes 14" and wider tires, brake kits are offered with 14" or 15" x 1.25" vented and cross-drilled rotors, with 4-piston Wilwood or Baer radial-mount calipers. An optional internal (drum-style) parking brake is also available to complete the system.

**INCREASED SAFETY:** Floating axle systems are required by many racing organizations for their greater reliability and safety. An extremely important benefit of a floater axle is the ability to keep the wheel attached to the vehicle and operational in the event of a broken axle, preventing additional damage to the body, suspension, and possibly others.

### Features/Benefits:

- Heavy-duty billet housing end with integrated caliper bracket bosses
- Heavy-duty wheel hub assembly; larger, stronger, more reliable than Corvette ZR1 hub
- 35-spline differential
- Internal drum-style parking brake; separates from rotor
- 14" or 15" rear disc brakes with Wilwood or Baer radial-mount calipers



# Pro-Touring Floater Axle System

■ NEW PRODUCT

Floater axles are 35-spline and available in ten different lengths to accommodate Ford 9" housing widths ranging from 50 to 61 inches. Axle shafts are machined from Hy-Tuf alloy steel specifically selected for its high strength and fatigue resistance properties.



8557-0135	PRO-TOURING FLOATER AXLES (SPINDLE-A) X 35-SPLINE DIFFERENTIAL - PAIR OF AXLES WITH ATTACHING HARDWARE.
OPTIONS	AXLE LENGTH: 51 TO 61 INCHES PINION OFFSET: CENTERED, 1/2" OFFSET, 1" OFFSET
NOTE	SPECIAL ORDER PART NOT RETURNABLE FOR ANY REASON



**Chassisworks Stocks 10-Different Lengths** - Axles are shipped in lengths ranging from 23" to 32" for housings ranging from 50" to 61". The splined area of each shaft is excessively long to allow shortening of the axle for specific lengths.



Larger diameter and spline count for significant strength increase over 31-spline axles.

# Pro-Touring Floater Axle System

NEW PRODUCT

## TAPERED UNIT-BEARING HUB

The heavy-duty bearing hub featured in Chassisworks floater axle system out performs the Corvette ZR1 hub as a result of its larger size and higher load capacity. Its opposing tapered-roller-bearing design is better suited for extreme side loads, minimizing brake pad 'knock-back' and improving brake pedal consistency in high-performance applications.



## Bearing Hub Comparison



Chassisworks



Corvette



Chassisworks



Corvette

## Exploded View

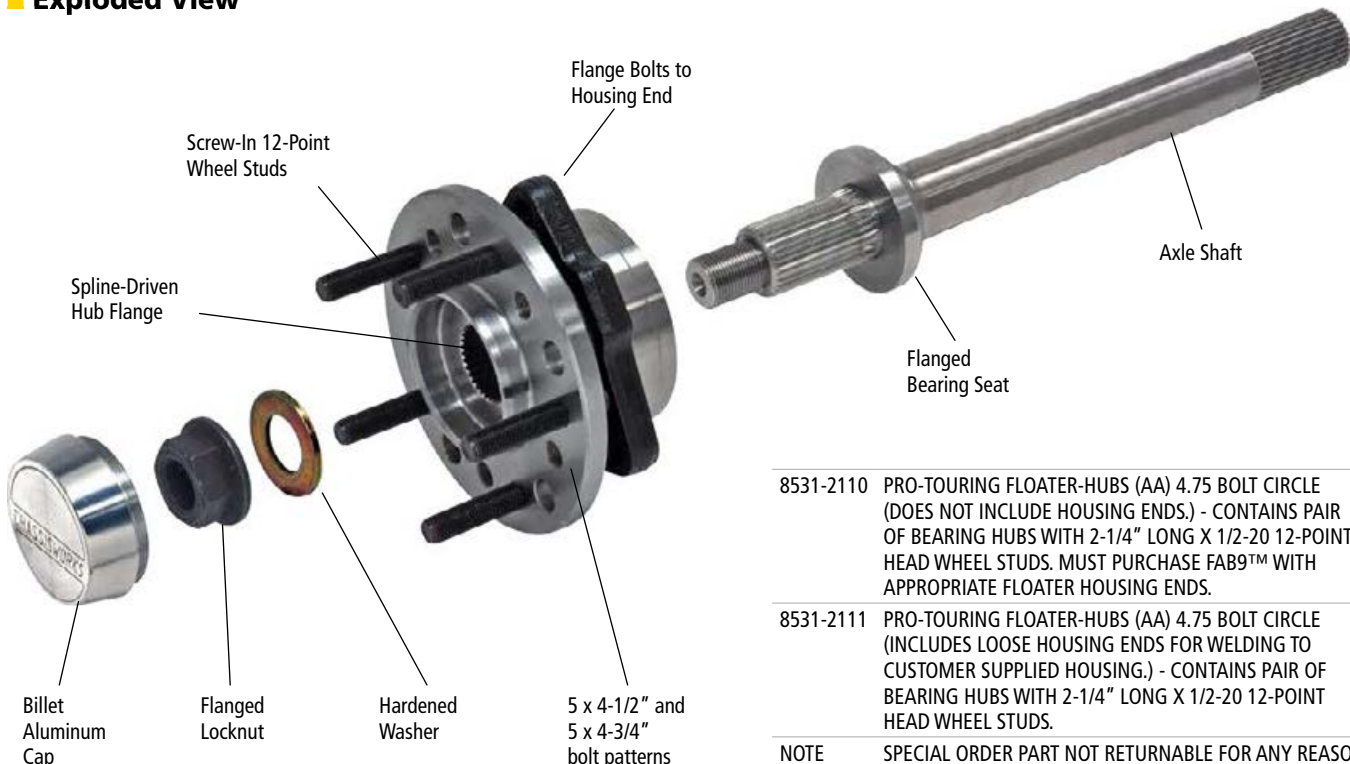

8531-2110 PRO-TOURING FLOATER-HUBS (AA) 4.75 BOLT CIRCLE (DOES NOT INCLUDE HOUSING ENDS.) - CONTAINS PAIR OF BEARING HUBS WITH 2-1/4" LONG X 1/2-20 12-POINT HEAD WHEEL STUDS. MUST PURCHASE FAB9™ WITH APPROPRIATE FLOATER HOUSING ENDS.

8531-2111 PRO-TOURING FLOATER-HUBS (AA) 4.75 BOLT CIRCLE (INCLUDES LOOSE HOUSING ENDS FOR WELDING TO CUSTOMER SUPPLIED HOUSING.) - CONTAINS PAIR OF BEARING HUBS WITH 2-1/4" LONG X 1/2-20 12-POINT HEAD WHEEL STUDS.

NOTE SPECIAL ORDER PART NOT RETURNABLE FOR ANY REASON

## FLOATER HOUSING END

Each floater package includes a pair of billet-steel housing ends for installation with an existing housing or as part of a factory-welded FAB9 housing. Floater housing ends feature an O-ring sealed mounting bore for the unit-bearing as well as caliper mounting-bracket extensions along both edges.

Housing ends available unassembled or factory-welded with FAB9 housing

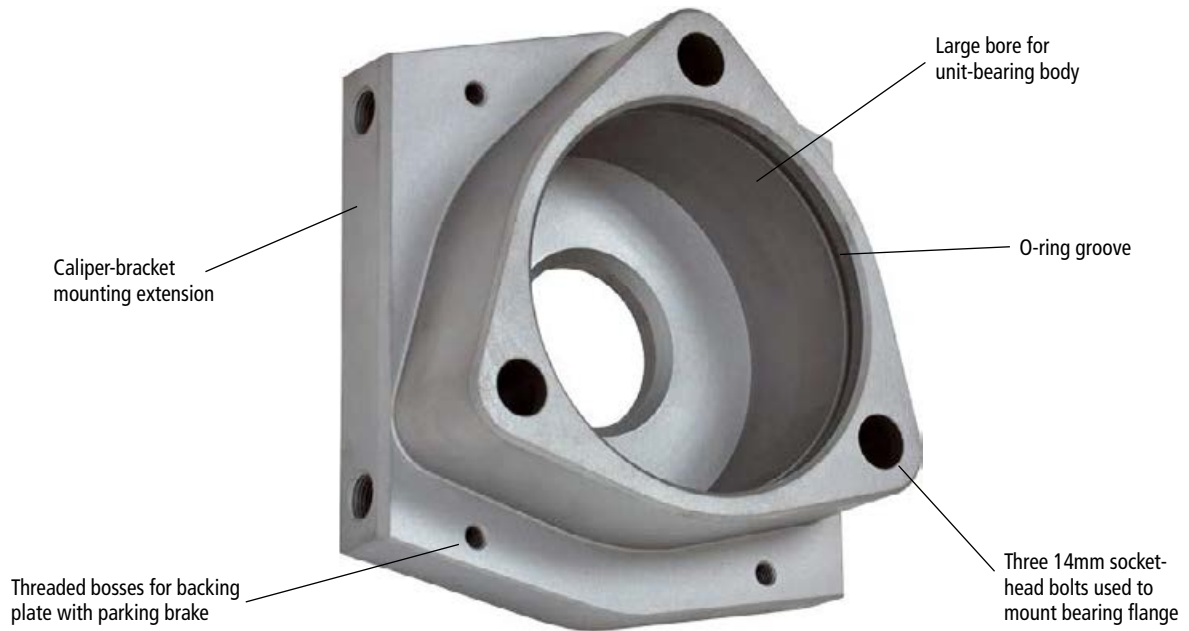

Housing end with backing plate and parking brake assembly.



Backing plate, parking brake, and hub mounted on housing end.

# Pro-Touring Floater Axle System

■ NEW PRODUCT

## ■ GSTREET BRAKES FOR FLOATER HOUSING END

gStreet brake kits for Chassisworks floater housing end feature radial-mount, four-piston calipers, and 14" or 15" directional-vented rotors with billet aluminum hats. The complete brake kit features an optional internal, drum-style, parking brake mechanism, which can be omitted from the kit in race or track only applications. The bolt-together hat-rotor-drum assembly allows worn or damaged components to be replaced easily and economically.

Enhanced-friction ceramic-formula brake pads provide smooth engagement, long service life, low noise, and light brake-dust levels for performance driving applications; performance specific pads are also available for autocross and road race applications. The kit is designed for use with rearend housing using Chassisworks' gStreet floater axle system and housing end. Fourteen- and fifteen-inch rotors require 18" and 19" wheels respectively. Includes SRP drilled (black e-coated) rotors, Wilwood calipers (black, red or nickel finish with optional Thermlock™ heat-barrier pistons), or Baer one-piece calipers.



Shown with W4A calipers



8380	GSTREET 14" SRP ROTORS, 4-PISTON AERO4 CALIPERS, NO PARKING BRAKE (BLACK OR RED)	2,255-UP
8381	GSTREET 15" SRP ROTORS, 4-PISTON AERO4 CALIPERS NO PARKING BRAKE (BLACK OR RED)	2,461-UP
OPTIONS	BLACK OR RED POWDER-COAT FINISH CALIPERS	INCLUDED
	NICKEL-COATED CALIPERS WITH THERMLOCK™ HEAT-BARRIER PISTONS	UPGRADE
	STREET AND PERFORMANCE SMART PAD (LOW NOISE, LIGHT DUST)	INCLUDED
	AUTOCROSS SPECIFIC PAD COMPOUND	UPGRADE
	ROAD RACE SPECIFIC PAD COMPOUND	UPGRADE
	BAER FORGED-MONOBLOCK CALIPERS	TBA
	PARKING BRAKE SYSTEM	

### Features/Benefits:

- 14" and 15" cross-drilled and vented rotors with black e-coat finish
- Internal, drum-style, parking brake option
- Wilwood Aero4 4-piston, radial-mount calipers; black, red or nickel finish with Thermlock® pistons
- Optional Wilwood brake pad compounds
- Baer 6S 6-piston, radial-mount calipers

# Pro-Touring Floater Axle System

■ NEW PRODUCT

## ■ WILWOOD AERO4 4-PISTON CALIPERS

The Aero4 four-piston rear caliper has been specifically matched with the Aero6 six-piston front caliper to deliver heavy-duty, balanced, stopping power for the road or track. The caliper incorporates race technology into a body design with widespread adaptability. Radial mounting and a rotor diameter range from 14.00" to 15.00" give this caliper the versatility necessary to suit all types of heavy weight braking requirements. Available in black or red powder coat finish, or optional nickel finish with Thermlock™ heat-barrier pistons.



## ■ Wilwood ThermLock® Pistons (Nickel-coated caliper only)

Thermlock® pistons block heat transfer from the pads and reduce temperatures in the caliper, fluid, and seals by up to 25% over standard stainless steel pistons. These are the

go-to calipers for all types sustained hard braking on a wide range of autocross, rally and road course applications.



## ■ Brake Pad Compounds

The standard street and performance pads included with the gStreet brake kits are suitable for everyday use and occasional performance driving. We recommend upgrading pad compounds for regular autocross and road race use.



### Brake Pad Compounds

STREET/PERFORMANCE	LOW NOISE AND DUST LEVELS
AUTOCROSS	AGGRESSIVE GRIP AT AMBIENT TEMPERATURE
ROAD RACE	AGGRESSIVE GRIP WITH HIGHER TEMPERATURE RANGE

## ■ BAER 6S 6-PISTON FORGED-MONOBLOCK CALIPERS

The Baer 6S is a forged-monoblock 6-piston caliper for pro-touring projects that need race car performance. To maximize strength the 6S caliper is machined from a single aluminum-alloy forging and utilizes an external crossover tube. Calipers feature stainless steel pistons, noise suppression springs, and staggered piston sizes to minimize pad wear. Available in red, black or silver powder-coat finish.



# Pro-Touring Floater Axle System

■ NEW PRODUCT

## ■ SRP DRILLED PERFORMANCE ROTORS

gStreet brake kits feature directional-vaned, cross-drilled rotors measuring 14" or 15" x 1.25"-wide. To create more surface area and maximize cooling, individual passages are cast internally into the rotor. Air passages or vanes are directional and curved for increased airflow over standard straight vented rotor designs. The slotted surface and cross-drilled holes improve pad-to-rotor contact by wiping the pad clean and allowing brake dust and gases to be easily exhausted. Rotors are black e-coated to prevent rust on internal and external rotor surfaces.



■ 14" and 15" rotors for big-tire, high-performance Pro-Touring builds

## ■ gStreet 15"



15 x 1.25"

## ■ gStreet 14"



14 x 1.25"



CHASSISWORKS  
**Chassisworks**  
THE HOME OF HIGHER TECHNOLOGY

**Any way you slice it...  
that's a BIG ASS ROTOR!**

The new 15" front brake kit for Chassisworks gStreet front clip systems.

# Pro-Touring Floater Axle System

■ NEW PRODUCT

## ■ DRUM-STYLE PARKING BRAKE

A specially designed parking brake kit had to be developed to work with the floater system's larger unit-bearing hub. The drum is independent of the rotor and fits neatly inside. Purchase and installation of the parking brake and drum kit is optional.

*...specifically designed to blend a street-friendly, parking-brake feature with a no-nonsense performance vehicle.*



The Chassisworks drum-style parking brake assembly is unique to our floater axle system and was specifically designed to blend a street-friendly, parking-brake feature with a no-nonsense performance vehicle.



The lightweight, billet-steel brake drum is a separate component from the rotor-hat assembly.



A single-band brake pad maximizes pad to drum contact area, requiring less pressure to effectively lock the wheel.



The complete parking brake assembly fits neatly within the brake rotor with ample room for air to flow freely through the rotor vents.

# 14" and 13" Rear Discs with Parking Brake

## ■ Billet SL4R Radial Mount Caliper

The Performance 14" and 13" kits use Wilwood's SL4R four-piston, billet aluminum, radial mount caliper for its superior rigidity, enhanced braking performance and pedal feel. These calipers use a closed end design that is further strengthened by five steel bridge bolts extending through the caliper body and directly across the brake pads. Smooth surface transitions help to eliminate stress points and reduce overall caliper deflection. The SL4R caliper uses lightweight, coated aluminum pistons and high temperature rubber boots to seal out debris from the piston bores. The total seal design reduces unnecessary wear, increasing the service life of the pistons. Caliper fluid requirements are matched to the output capabilities of commonly used factory master cylinders ensuring comfortable performance in a wide range of applications. Vibration dampening stainless steel bridge plate inserts protect the caliper body from wear caused by pad movement, greatly extending

service life. Dampened external fluid tubes are routed through recessed pockets to keep clear of debris and reduce the potential of vibration induced wear at the fittings. Two-piece bleed screws are easily accessed at the top

of each side of the caliper body and eliminate direct wear to the aluminum body. Brake pads are also

changed easily by simply removing the center bridge bolt and sliding the pads out.

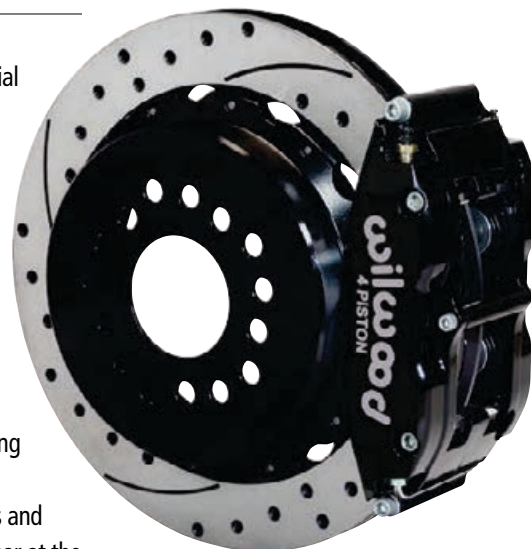

SRP Rotor

## ■ High Performance Vented Disc Rotors

The kit comes standard with HP series, vented, smooth surface, rotors with integrated drum and measure 14" x 1.10", or 13" x .81".

The HP rotors come uncoated and can withstand extreme operating temperatures for extended periods of time; ideal for high performance applications. For more eye-catching high-end street performance, rotors can be upgraded to a SRP series vented, cross-drilled, slotted and zinc washed rotor. To maximize cooling surface area, individual air passages are cast internally into each rotor. Air passages or vents offer increased airflow and cooling capability over standard solid rotor designs. The optional SRP rotor with slotted surface and cross-drilled holes improve pad to rotor contact by wiping the pad clean and allowing brake dust and gases to be easily exhausted.

## ■ 2-piece Steel Hat Drum

Separate machine finished, cast steel hats provide the holding drum for the parking brake shoes and allow components to be easily replaced if damaged or worn. Rotors and hats are secured in a 12-bolt configuration to provide additional stability to the rotor. Hats are drilled for multiple five-lug bolt patterns and accept 1/2" wheel studs.

## ■ Billet Aluminum Bracket Assembly

The parking-brake, and caliper-bracket assembly is machined from high-strength billet aluminum. Structural mounting points on each bracket receive spline-threaded steel inserts, reducing the mounting hardware and simplifying installation. All components are anodized, painted, or plated for corrosion resistance and extended service life.

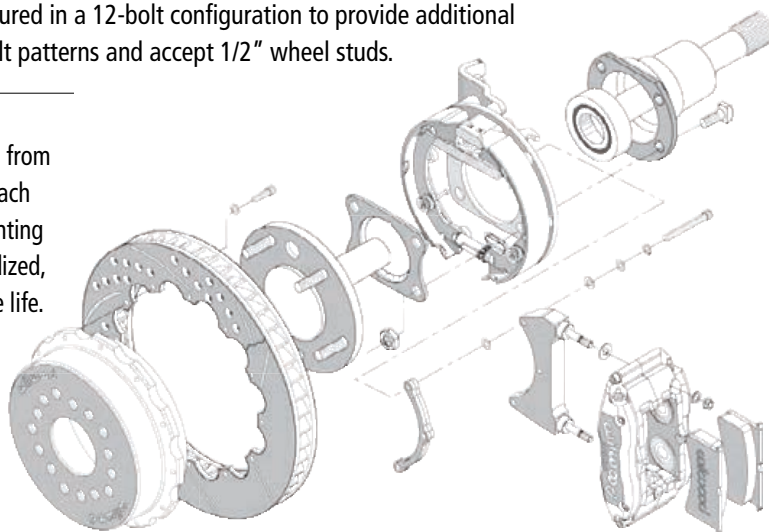
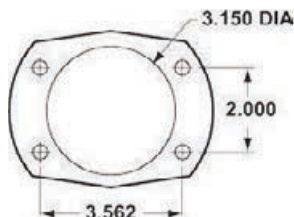

## ■ Performance 14"

HOUSING STYLE	AXLE OFFSET	HP ROTOR \$1,620.00	SRP ROTOR \$1,720.00
BIG FORD (LATE/TORINO)	2.50"	WW 140-10012	WW 140-10012-D
OPTION: RED POWDER-COATED CALIPERS \$155 (PAIR)			

## ■ Performance 13"

HOUSING STYLE	AXLE OFFSET	HP ROTOR \$1,495.00	SRP ROTOR \$1,595.00
BIG FORD (LATE/TORINO)	2.50"	WW 140-9219	WW 140-9219-D
OPTION: RED POWDER-COATED CALIPERS \$155 (PAIR)			

# Street 12.19" Rear Discs with Parking Brake

## ■ Forged Dynalite Caliper

The Wilwood rear disc brake kit uses Forged Dynalite (FDL) four-piston, aluminum, lug mount caliper for its superior rigidity, enhanced braking performance and pedal feel. The calipers use a closed end, internal fluid passage design that is further strengthened by four steel bridge bolts extending through the caliper body. Stress flow forging and smooth surface transitions help to eliminate stress points and reduce overall caliper deflection. FDL calipers use one-piece, 1.38" -bore, stainless-steel pistons and high-temperature, square-faced bore seals. Stainless steel slows heat transfer to the brake fluid and improves the systems resistance to heat induced pedal

fade. This reduction in heat also increases the service life of the fluid and seals. The four individual pistons apply pressure against both sides of the rotor. Caliper fluid requirements are matched to the output capabilities of

commonly used factory master cylinders ensuring comfortable performance in a wide range of applications. The Dynalite calipers are trouble-free and service friendly. Vibration-dampening, stainless-steel bridge plate inserts protect the caliper body from wear caused by pad movement, greatly extending service life. Two-piece bleed screws are easily accessed at each corner of the caliper body and eliminate direct wear to the aluminum body. Brake pads are also easily changed by simply removing the retaining pin and sliding the pads out.



## ■ High Performance Disc/Drum Rotors

The kit comes standard with HP series, vented, smooth surface, rotors with integrated drum and measure 12.19" x .81". The HP rotors come uncoated and can withstand extreme operating temperatures for extended periods of time; ideal for high performance applications. For more eye-catching high-end street performance, rotors can be upgraded to a SRP series vented, cross-drilled, slotted and e-coated rotor. To maximize cooling surface area, 32 individual air passages are cast internally into each rotor. Air passages or vents offer increased airflow and cooling capability over standard solid rotor designs. The optional SRP rotor with slotted surface and cross-drilled holes improve pad to rotor contact by wiping the pad clean and allowing brake dust and gases to be easily exhausted.



HP Rotor



SRP Rotor

## ■ Billet Aluminum Bracket Assembly

The parking brake and caliper mounting bracket assembly is machined from lightweight, high-strength billet aluminum. Structural mounting points on each bracket receive spline-threaded steel inserts, reducing the mounting hardware and simplifying installation. All components are anodized, painted, or plated for corrosion resistance and extended service life. Brackets are available for all standard housing ends.

HOUSING STYLE	AXLE OFFSET	HP ROTOR \$649.00	SRP ROTOR \$753.00
BIG FORD (LATE/TORINO)	2.50"	WW 140-7140	WW 140-7140-D
OPTION: RED POWDER-COATED CALIPERS \$100 (PAIR)			

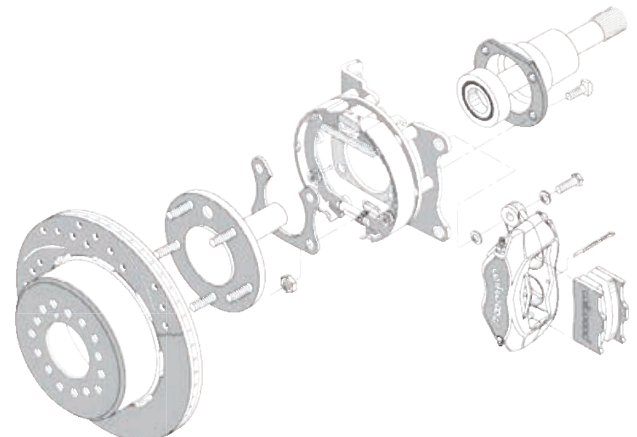
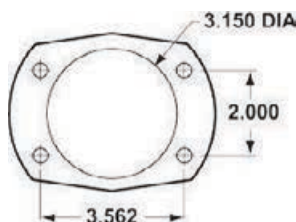

# Tandem Chamber Master Cylinders

The Wilwood master cylinder is a direct-mount, high-quality upgrade designed for use with aftermarket brake systems. Master-cylinder bodies are die cast using premium aluminum alloy for increased durability with minimal weight. Exterior finishes are available "as-cast" or "bright finished," using a media-burnishing technique. Caps are black-anodized, machined aluminum and secured by four fasteners to provide a leakproof seal. Units are available with .88", 1.00" (manual) and 1.13" (power) bore sizes and feature a 2:1 volume ratio between the primary and secondary chambers. Includes tube-adaptor set.



## ■ Die-Cast Construction

High-pressure die casting of a premium alloy produces a high-capacity body that is lightweight, looks great, and has the durability for competition. Die casting has the benefit of producing detailed components with excellent dimensional tolerance and surface finish without the need for expensive machine time of an equivalent billet part. The result is a lightweight, great-looking part that performs, and at a fraction of the cost. Available for those wanting a show-car look is a bright-finish, media-burnished version (pictured), guaranteed to catch the eye of the most-discriminating enthusiasts.

## ■ 100%-Fluid Seal

A black-anodized, machined-billet lid captures a pressure-balanced bellows gasket for 100% sealing against moisture invasion or fluid leakage. The aluminum lid is vented, allowing the bellows to react to chamber vacuum independently, without disruption of the seal.



## ■ Fluid Volumes

A total piston stroke of 1.10" is distributed at a 2:1 volume ratio between the primary and secondary chambers. A choice of either .88", 1.00" or 1.13" bore sizes provides the necessary options to match the volume and pressure requirements of nearly any application. Generally, the .88" and 1.00" bores are used for manual brakes, and 1.13" for power brakes.

## ■ Bolt-On Installation

The mounting flange is slotted to accommodate installation on bolt centers between 3.22" and 3.40". It directly bolts on to many OE mounts, including the popular Ford Mustang, Chrysler, GM and Corvette master-cylinder bolt patterns. The body also features two through-hole mounts on 6.40" centers for side mounting to frame members or other secure elements of the chassis.



## ■ Plumbing Versatility

Each master cylinder is configured with full separation between the front and rear reservoir chambers and fluid outlets. There is pressure access on both sides of the piston bore for right- or left-hand plumbing (based on mount location). Included with the master cylinder are fittings, for various installation configurations. They include one tube adapter measuring 1/2-20x9/16-18 IF (P/N 220-8575); one tube adapter measuring 1/2-20x1/2-20 IF (P/N 220-8574); and two tube adapters measuring 1/2-20x3/8-24 IF. (IF = Inverted Flare)

PART NUMBER	BORE SIZE	APPLICATION	FINISH	PRICE
WW 260-9439	0.88"	MANUAL	STANDARD	\$200.00
WW 260-8555	1.00"	MANUAL	STANDARD	200.00
WW 260-8556	1.13"	POWER	STANDARD	200.00
OPTIONS	BLACK E-COAT FINISH (ADD "BK" P/N SUFFIX)			ADD 40.00
	BRIGHT FINISH (ADD "P" P/N SUFFIX)			ADD 40.00

# Brake System Accessories

To complement our line of brake kits and components, these additional items will enable you to fine-tune your brake system for improved performance. The proportioning valve provides brake-bias adjustment to optimize available traction and heavy-braking stability. Residual pressure valves maintain line pressure at the caliper or wheel

cylinder to provide a firmer pedal and more-immediate braking response. The caliper-pressure gauge allows precise measurement of line pressure to ensure the system is working correctly as well as establishing an adjustment from which to begin.

## ■ Braided-Stainless Flex-line Kit

Our braided-stainless, flex-line kit reduces line flex, common with OEM brake lines, to improve brake system response, and pedal feel. Teflon® hoses, hose ends, and mounting brackets are included.

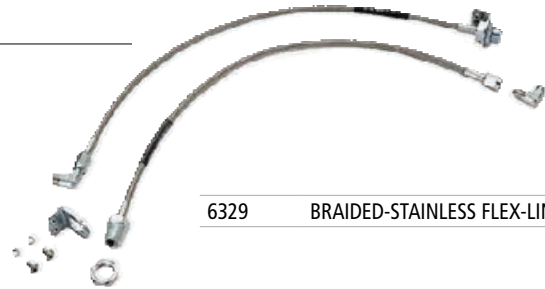

6329	BRAIDED-STAINLESS FLEX-LINE KIT	\$89.00
------	---------------------------------	---------

## ■ Proportioning Valve

The Wilwood proportioning valve uses a compact, lightweight (5.2 oz.), forged-billet design and is an essential component for fine-tuning your brake system. Pressure adjustments range from 100-1000 psi and provide for a maximum decrease of 57% in line pressure, the most of any valve. The valve is typically installed inline to adjust rear brake-line pressure, but can also be installed to reduce front brake-line pressure in skinny-tire Pro Street or drag-racing vehicles.



WW 260-8419	PROPORTIONING VALVE	\$42.00
-------------	---------------------	---------

## ■ Residual Pressure Valves

The Wilwood inline pressure valves retain a minimum brake-line pressure to help eliminate excessive pedal travel in disc- and drum-brake systems. Vehicles equipped with drum brakes require a 10-psi residual-pressure valve to counteract spring tension. The 2-psi valve is used on disc-brake systems with master cylinder mounted below the calipers. Valves are available individually or packaged with fittings.



WW 260-1874	2 PSI DISC BRAKE RESIDUAL VALVE ONLY	\$18.00
WW 260-1876	10 PSI DRUM BRAKE RESIDUAL VALVE ONLY	18.00
WW 260-3278	2 PSI DISC BRAKE RESIDUAL VALVE WITH FITTINGS	20.00
WW 260-3279	10 PSI DRUM BRAKE RESIDUAL VALVE WITH FITTINGS	20.00

## ■ Caliper Pressure Gauge

The easy-to-read, 2"-diameter, non-hazing face allows for quick brake-line-pressure checks from 0-1500 psi. Twenty-psi graduations and accuracy to 1.5% permit reliable brake-bias setup and brake-system troubleshooting. Gauge threads directly in place of bleeder valve.



WW 260-0966	CALIPER PRESSURE GAUGE	\$68.00
-------------	------------------------	---------

# VariShock Technology

## ■ VariShock Design

The VariShock product line offers an affordable and versatile, high-end performance improvement over OEM replacements and traditional twin-tube shock absorbers. Our updated design overcomes the major shortcomings of traditional gas shocks and low-end twin-tube shocks. VariShocks provide a more usable adjustment range and response curve, improved heat dissipation, and lightweight billet-aluminum construction.

## ■ Improved Heat Dissipation

Traditional twin-tube shocks provide damping force by moving fluid back and forth between the inner compression tube and the surrounding reservoir. This rapidly heats the fluid that remains trapped inside the compression tube, causing outgassing and shock fade. VariShock's system of internal valves circulates fluid in a single direction through the shock absorber body, utilizing the entire volume of fluid to absorb heat. Thermally conductive materials are used internally to further help equalize fluid temperature. Heat energy is then dissipated through the shock base and body. Coil-over threaded bodies provide additional surface area for more rapid cooling.

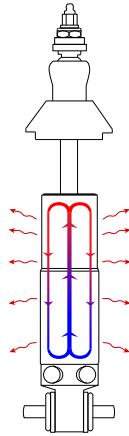

## ■ Fluid Control

A shock's purpose is to limit the rate at which the suspension moves, whether induced by road irregularities or by chassis movement. By carefully controlling the rate of fluid flow into the different areas of the shock we can better manage the suspension's ability to keep the tire in contact with the road. VariShocks operate with zero bleed, meaning that absolutely all fluid flow is purposely directed and metered. By contrast, many manufacturers skimp on sealing the shocks internals to lower manufacturing costs. The allowed internal leakage makes valving adjustments less effective and lacking in precision. The VariShock total-seal design gives you improved control over the entire range of damping and enhances adjustment effectiveness at the slower range of piston speeds (0-4 in/sec) that control small chassis movement and vehicle ride quality.

A combination of fatigue-resistant deflective-disk and adjustable poppet valves focus damping forces at a range useful to the widest variety of vehicle types and performance applications. Damping-force ranges differ depending upon the adjustment features and mounting configuration of the shock. Custom valve sets are also available to alter the adjustment range of compression or rebound independently. VariShocks provide digressive damping to permit finer adjustment at the higher range of piston speeds (6-12 in/sec)

that control rapid suspension movement and ride harshness. To give better control of vehicle-handling without rapidly increasing ride harshness, rebound (extension) valving is purposely stiffer with a broader adjustment range.

## ■ VariShock Quality

Delivering a finished product that is of excellent quality and value is the primary focus throughout the VariShock product line. Unlike other brands in this price range, VariShocks are engineered, manufactured, and assembled in America using state-of-the-art engineering workstations and computer-numeric-controlled (CNC) manufacturing equipment. Each component, including valves, adjusters, and internal shaft seals is designed and manufactured specifically for use in VariShock products. This level of clean-sheet engineering is the first step to producing longer lasting seals that keep dirt out of the shock absorber and extend service life between rebuilds.

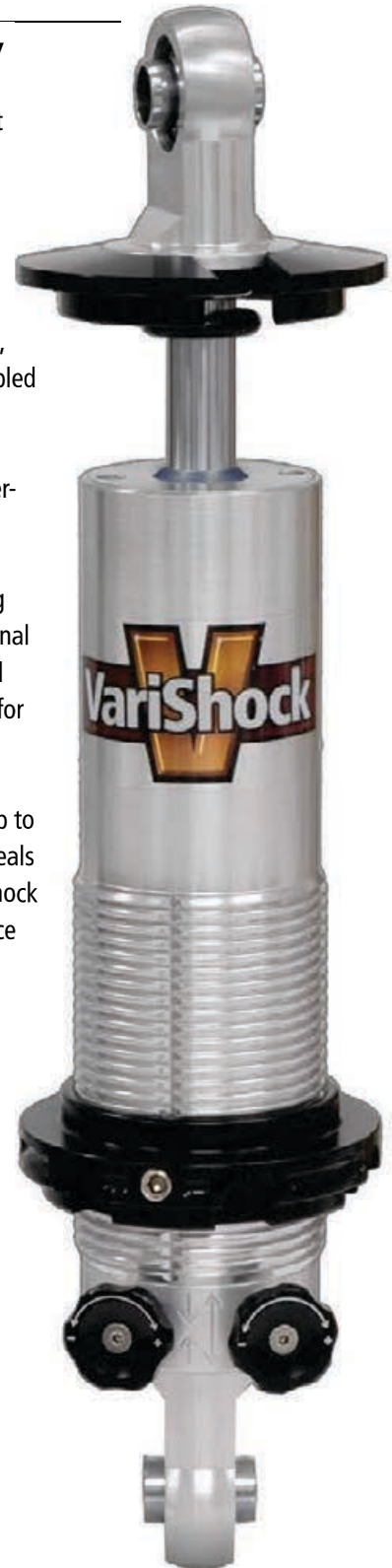

# VariShock Technology

Assembly of the components is equally important to delivering a quality product. To avoid the possibility of manufacturing debris contaminating the shock fluid and seals, the VariShock-assembly clean room is housed in a completely separate facility. After assembly, each shock is thoroughly dyno-tested and calibrated to meet VariShock's strict performance goals. This ensures virtually identical performance from every pair throughout their entire

## ■ Adjustable QuickSet Series

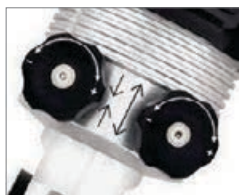

The VariShock QuickSet series allows you to easily tune your suspension for improved cornering and acceleration traction, or to quickly adapt to current track conditions. Adjustment takes only a few seconds and is made with the

VariShock installed on the vehicle. Readily accessible, 16-position adjustment knobs can be operated by hand or with the aid of a common allen wrench.

The QuickSet 1 valve system features a single adjustment knob that controls overall damping stiffness of the shock. Knobs are clearly etched indicating the correct direction of rotation to decrease (-), or increase (+) damping stiffness. There are a total of 16 specific adjustment positions.

The QuickSet 2 valve system features dual adjustment knobs that independently control bump- and rebound-damping stiffness of the shock. Dual-arrow symbols engraved into the shock

range of travel. By carefully controlling engineering, manufacturing, assembly, and final testing, VariShock can confidently deliver the highest-quality product with the most value for our customers.



body demonstrate the function of each knob. Arrows pointing toward each other designate bump (compression) adjustment; the shock collapsing. Arrows pointing away from each other represent rebound (extension) adjustment; the shock extending. There are 16 specific adjustment positions for each knob, with a total of 256 unique combinations possible. Each adjustment position is indicated by a detent that can be felt when turning the knob, and an audible click as the knob gently locks into position. Only very light force is necessary to rotate the knob past each detent.

## ■ The Truth About 16- vs. 24-Clicks

Don't be fooled by shocks offering more adjustment clicks. They are actually 1/2-click adjustments. The manufacturer merely added more detents to the mechanism without increasing the range of adjustment. This practice gives more clicks, but the

adjustment is so slight that your vehicle will not respond to the change. A 16-position VariShock actually has a broader range of adjustable force with the added benefit of a more manageable number of adjustments to try.

## ■ VariShock Dyno Graph

A shock dyno graph displays how much force is required to compress or extend the shock over a range of piston speeds (Force vs. Absolute Velocity). For readability purposes, the following graph only plots response curves for every other adjustment setting of the Bolt-In QuickSet 2 VariShock. The shock's digressive valving curve can be easily identified by the steeper incline in the slowest piston speeds and more level response as piston speed increases. Each setting provides an even increase of stiffness in relatively even increments across the entire range without deviation from the general response curve. This consistency can be found throughout the VariShock product line and makes suspension tuning simple and intuitive. VariShock compression and rebound adjustments are completely independent from each other. Adjustment of one direction of shock travel does not inadvertently affect the other, enabling you to find the correct settings for your vehicle in less time.

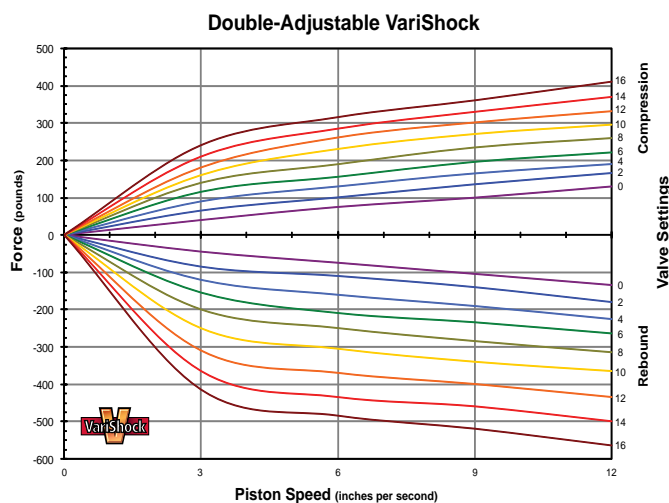

Graph displays valving curve of QuickSet 2 double-adjustable shock. Valving curves of VariStruts and QuickSet 1 products will differ.

# VariShock Coil-Overs

- 4-Way Adjustable Remote Reservoir Shocks
- Double-Adjustable Coil-Over Shocks
- Single-Adjustable Coil-Over Shocks
- VariSpring Coil Springs with choice of rate



## ■ FRONT Coil-Over Shocks, 4.25" Travel

VAS 11111-425	SINGLE-ADJUSTABLE (QUICKSET 1) BEARING-EYE COIL-OVER, 4.25" TRAVEL (PAIR)	\$498.00
VAS 11211-425	DOUBLE-ADJUSTABLE (QUICKSET 2) BEARING-EYE COIL-OVER, 4.25" TRAVEL (PAIR)	698.00
VAS 11411-43	4-WAY-ADJUSTABLE REMOTE RESERVOIR (QUICKSET 4R) BEARING-EYE COIL-OVER, 4.25" TRAVEL (PAIR)	1,790.00
NOTES	USES 9" COIL SPRINGS (SOLD SEPARATELY) SHOCKS ARE INCLUDED IN GSTREET PACKAGES. FULL RETAIL PRICES LISTED IN THIS CHART. UPGRADE PRICES LISTED IN CHASSIS PACKAGE PRICE LIST.	

MOUNTING EYES	TOTAL TRAVEL	COLLAPSED LENGTH	EXTENDED LENGTH	RIDE-HEIGHT MINIMUM	RIDE-HEIGHT MAXIMUM	SPRING LENGTH
COM-8	4.25"	10.05"	14.30"	11.75"	12.60"	9"

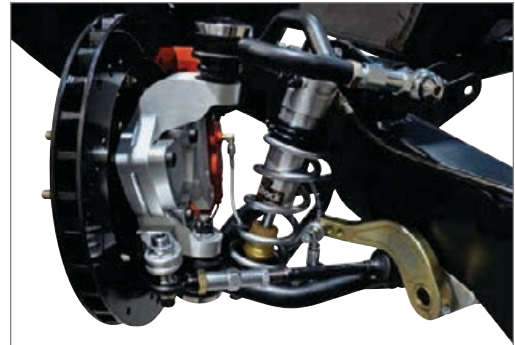

## ■ REAR Coil-Over Shocks, 5.15" Travel

VAS 11111-515	SINGLE-ADJUSTABLE (QUICKSET 1) BEARING-EYE COIL-OVER, 5.15" TRAVEL (PAIR)	\$498.00
VAS 11211-515	DOUBLE-ADJUSTABLE (QUICKSET 2) BEARING-EYE COIL-OVER, 5.15" TRAVEL (PAIR)	698.00
VAS 11411-50	4-WAY-ADJUSTABLE REMOTE RESERVOIR (QUICKSET 4R) BEARING-EYE COIL-OVER, 5.00" TRAVEL (PAIR)	1,678.00
NOTES	USES 12" COIL SPRINGS (SOLD SEPARATELY) SHOCKS ARE INCLUDED IN GSTREET PACKAGES. FULL RETAIL PRICES LISTED IN THIS CHART. UPGRADE PRICES LISTED IN CHASSIS PACKAGE PRICE LIST.	

MOUNTING EYES	TOTAL TRAVEL	COLLAPSED LENGTH	EXTENDED LENGTH	RIDE-HEIGHT MINIMUM	RIDE-HEIGHT MAXIMUM	SPRING LENGTH
COM-8	5.00"	10.81"	15.81"	12.81"	13.81"	12"
COM-8	5.15"	10.95"	16.10"	13.01"	14.04"	12"



# Remote Reservoir 4-Way Coil-Over

■ NEW PRODUCT

## ■ QUICKSET 4 REMOTE RESERVOIR (Q4R)

Our gas-pressurized remote reservoir QuickSet 4 system offers excellent performance with increased travel range at an affordable price when compared to shocks offered by other manufacturers with similar features.

Four 16-position knobs provide high- and low-speed adjustment of bump and rebound independently. The Q4R 4-way valve system is VariShock's most versatile and flexible tuning option with thousands of shock-force-curve variations possible. To support this level of tuning sophistication VariShock provides detailed technical guides to assist you throughout the tuning process.

VariShocks are engineered, manufactured, and assembled in America using state-of-the-art engineering workstations and computer-numeric-controlled 5-axis (CNC) manufacturing equipment. Each component, including valves, adjusters, and internal shaft seals is designed and manufactured specifically for use in VariShock products. This level of clean-sheet engineering was the first step to producing an excellent product that can be adjusted to your exact needs.

*Why settle for a 3-Way adjustable...  
...when you can have a 4-Way?*



■ **Separate 16-Position High- and Low-Speed Adjustment of Bump and Rebound**

PART NUMBER	DESCRIPTION	USAGE	SPRING	COMPRESSED	EXTENDED	TRAVEL	PRICE (EACH)
VAS 11411-43	QUICKSET 4 REMOTE RESERVIOR	BOTH	9"	10.06"	14.31"	4.25"	\$895.00
VAS 11411-50	QUICKSET 4 REMOTE RESERVIOR	REAR	12"	10.81"	15.81"	5.00"	895.00

NOTE: Sold only in pairs. Springs sold separately.

## ■ 4-Way Adjustable Valve System

The VariShock Q4R remote reservoir shock separates the bump and rebound valve mechanisms between the two units to free up valuable space within the main shock body. The benefit is a shorter shock length that provides greater flexibility when mounting without sacrificing shock travel. Each adjustment knob can be set to one of sixteen different positions and clearly marked to illustrate the effect it has on the shock's performance.

## ■ Bump Adjustment Independent High- and Low-Speed

Located at the base of the remote reservoir are the bump valve adjustment knobs. The facing arrows represent the shock coming together (bump/compression) with the letters "L" and "H" labeling the low-speed and high-speed knobs respectively. "Plus" and "minus" signs etched into each knob show the rotation direction to increase or decrease valve stiffness.



## ■ Rebound Adjustment Independent High- and Low-Speed

The rebound valve adjustment knobs are located on the base of the shock. The opposing arrows represent the shock separating (rebound/extension) with the letters "L" and "H" labeling the low-speed and high-speed knobs respectively. "Plus" and "minus" signs etched into each knob show the rotation direction to increase or decrease valve stiffness.



Double-Swivel Banjo  
...can be rotated 360-degrees for hose clearance. Plus the hose can rotate 360-degrees to position the reservoir without kinking the hose.



# Remote Reservoir 4-Way Coil-Over

NEW PRODUCT



Reservoirs can be mounted to the forward strut bars with the optional 1-5/8" -round billet clamps. Flat-base clamps are also available for mounting against flat surfaces or panels.



Adjusting the shock preload and dampening can be done without removing the shock.



An optional shock mount inset is available with the trunk-area floor kit to cleanly display the reservoirs in the trunk.



Various hardware is available to assist in safely routing the reservoir hose. The rubberized clamp and bracket set, shown above, fits against the jam nut of any 3/4" thread rod end or adjuster.



The passage bulkhead provides a clean and safe way of passing the remote reservoir through any accessible flat surface and securing the hose.

# Remote Reservoir 4-Way Coil-Over

■ NEW PRODUCT

## ■ REMOTE RESERVOIR CLAMP MOUNTS

### ■ Remote Shock Reservoir Mount (2.225" ID), Clamp-Style - Flat Surface

Contains a pair of mounts to attach two 2.225" OD reservoir to a flat surface with 1/4" bolts on 2.00" spacing.



VAS 516-01-000 REMOTE SHOCK RESERVOIR MOUNT (2.225" ID), CLAMP-STYLE - FLAT SURFACE (PAIR) \$92.00

### ■ Remote Shock Reservoir Mount (2.225" ID), Clamp-Style - 1-5/8" Open

Contains a pair of mounts to attach two 2.225" OD reservoir to 1-5/8" tube.



VAS 516-01-163 REMOTE SHOCK RESERVOIR MOUNT (2.225" ID), CLAMP-STYLE - 1-5/8" OPEN (PAIR) \$133.00

### ■ Remote Shock Reservoir Mount (2.225" ID), Clamp-Style - 1" Pass-Through

Contains: a pair of mounts to attach two 2.225" OD reservoir to 1" OD tube, pass thru style.



VAS 516-01-100P REMOTE SHOCK RESERVOIR MOUNT (2.225" ID), CLAMP-STYLE - 1" PASS-THROUGH (PAIR) \$133.00



## ■ REMOTE RESERVOIR CLAMP MOUNTS

### ■ Remote Shock Reservoir Mount Silo-Style - Flat Surface

Set of mounts to attach two VariShock reservoirs to a flat surface requires 2-1/2" pass thru holes.

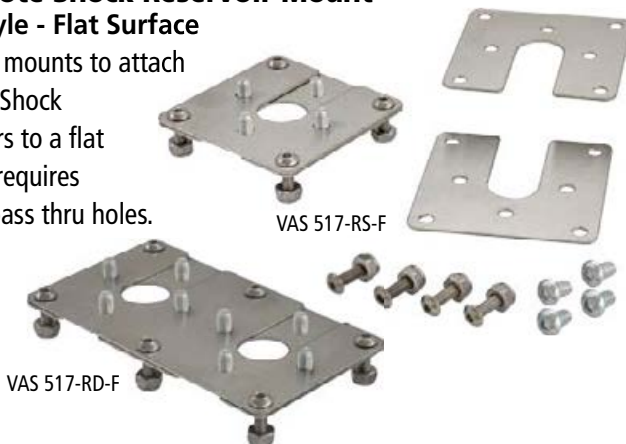

VAS 517-RD-F REMOTE SHOCK RESERVOIR MOUNT, SILO-STYLE (DUAL) - FLAT SURFACE (EACH) \$98.00

VAS 517-RS-F REMOTE SHOCK RESERVOIR MOUNT, SILO-STYLE (SINGLE) - FLAT SURFACE (PAIR) 119.00



# Coil-Over Shock Accessories

■ NEW PRODUCT

## ■ Remote Shock Reservoir Passage Bulkhead (2.5" ID x 1/2" Hose) Flat Surface

Set of closeouts to seal two VariShock reservoir hoses in separate locations to a flat surface requires 2-1/2" pass thru hole.



VAS 517-HS-F SINGLE HOSE FLAT SURFACE PASS THRU BULKHEAD (PAIR) \$71.00

## ■ Hose Clamp with Bracket Set – 3/4"-Bore Mount with 1/2" Hose Clamp

Teardrop UCA clamp 3/4" hole attaches -5 hose to any upper control arm with 3/4" adjuster.



VAS 517-HS-H TEARDROP UPPER CONTROL ARM CLAMP 3/4" HOLE (ATTACHES TO UCA ADJUSTER) (PAIR) \$30.00

## ■ Coil-Over Spring Seat Extended

Billet-aluminum upper spring seat with 3/4" -offset seat for 2-1/2" ID spring.



899-002-204

899-002-204 COIL-OVER SPRING SEAT EXTENDED (SOLD INDIVIDUALLY) \$30.00

## ■ Spring-Seat Thrust Bearings

Thrust bearings are used at the lower spring seat to reduce friction when adjusting ride height. New stainless "cap-style" seats, a VariShock exclusive, enclose the thrust bearing to keep dirt out.



VAS 513-100

VAS 513-100 SPRING-SEAT THRUST BEARINGS (PAIR) \$65.00

## ■ Coil-Over Spring Compressor

The VariShock coil-over-spring compressor greatly eases lower-spring-collar adjustment on high-preload or high-rate applications. Heavy-duty plates at each end fit 2-1/2" inside-diameter coil springs of 130 lb., rate or greater, with a maximum spring height of 14".

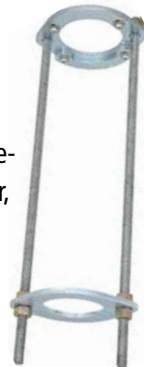

VAS 200

VAS 200 COIL-OVER SPRING COMPRESSOR FOR 2-1/2" SPRINGS) \$67.00

## ■ Spanner Wrench

Also available is an exclusive spanner wrench, incorporating four tangs, which will not slip off the lower spring seat because it engages the seat in four places (not one, like common spanners).



899-012-201

899-012-201 VARISHOCK SPANNER WRENCH, ZINC PLATED STEEL \$31.00

## ■ Shock Simulators (Front Suspension)

Chassisworks' shock simulators take the guesswork out of aligning your g-Machine front suspension system. The laser-cut steel links bolt in place of the VariShock coil-over or air spring. Simulators feature holes spaced at three different lengths to quickly secure the suspension at full compression, at ride height, and at full extension. This tool is not designed to carry the weight of the vehicle.



6712-12 12" RIDE-HEIGHT SHOCK SIMULATORS, STEEL (PAIR) \$31.00

## ■ Shock-Mount Fasteners

We have three styles of shock-mount fasteners for our street-machine front suspension. The shock spuds are CNC-machined from stainless-steel billet. The male-and-female design allows the two halves to be tightened completely, providing the correct amount of crush on the shock's urethane bushings and sleeves. The internal hex machined into the end makes tightening easy. Polished finish assures a great, long-lasting appearance. Also available are stainless-steel Allen bolts or Grade-8 hex bolts.



3043 GRADE 8 HEX-HEAD CAP SCREWS, YELLOW ZINC \$12.00

3044 SOCKET-HEAD CAP SCREWS, STAINLESS STEEL 27.00

3045 BEVELED-HEAD SPUD SET, POLISHED STAINLESS STEEL 139.00

NOTE: INCLUDES HARDWARE FOR ONE PAIR OF SHOCKS

# VariSpring Coil Springs

VariSpring's line of coil springs was designed to complement the VariShock family. A new high-tensile wire is used that is stronger than the chrome-silicon wire used by other manufacturers. The improved material allows VariSprings to compress until the coils touch without damaging the springs or causing them to take a set, which adversely affects handling and randomly changes the spring height. This additional range of usable flex gives VariSprings greater travel than competitors' chrome-silicon springs of the same rate and permits the use of a more aggressive coil angle, reducing material used and overall weight. VariSprings can improve suspension control and available traction by allowing your shock to operate throughout its entire travel range.

VariSprings are available for front and rear applications in four lengths and a broad range of spring rates to suit a variety of shock and performance applications. Lengths range from 7 to 14 inches and rates from 80 to 850 pounds per inch, depending upon spring length. The steps between rates are sufficiently close to make very fine adjustments.



## ■ 12-inch VariSprings (REAR)

VAS 21-12080	12" LENGTH, 80 LB/INCH, TRAVEL = 8.63	\$124.00
VAS 21-12095	12" LENGTH, 95 LB/INCH, TRAVEL = 8.28	124.00
VAS 21-12110	12" LENGTH, 110 LB/INCH, TRAVEL = 7.91	124.00
VAS 21-12130	12" LENGTH, 130 LB/INCH, TRAVEL = 8.43	124.00
VAS 21-12150	12" LENGTH, 150 LB/INCH, TRAVEL = 7.61	124.00
VAS 21-12175	12" LENGTH, 175 LB/INCH, TRAVEL = 7.60	124.00
VAS 21-12200	12" LENGTH, 200 LB/INCH, TRAVEL = 7.45	124.00
VAS 21-12250	12" LENGTH, 250 LB/INCH, TRAVEL = 7.00	124.00
VAS 21-12300	12" LENGTH, 300 LB/INCH, TRAVEL = 7.07	124.00
VAS 21-12350	12" LENGTH, 350 LB/INCH, TRAVEL = 7.00	124.00
VAS 21-12400	12" LENGTH, 400 LB/INCH, TRAVEL = 6.35	124.00
VAS 21-12450	12" LENGTH, 450 LB/INCH, TRAVEL = 5.86	144.00
VAS 21-12500	12" LENGTH, 500 LB/INCH, TRAVEL = 5.06	144.00
VAS 21-12550	12" LENGTH, 550 LB/INCH, TRAVEL = 5.50	144.00
VAS 21-12600	12" LENGTH, 600 LB/INCH, TRAVEL = 5.17	144.00
VAS 21-12650	12" LENGTH, 650 LB/INCH, TRAVEL = 5.76	144.00

## ■ 9-inch VariSprings (FRONT)

VAS 21-09200	9" LENGTH, 210 LB/INCH, TRAVEL = 5.64	\$124.00
VAS 21-09240	9" LENGTH, 240 LB/INCH, TRAVEL = 5.57	124.00
VAS 21-09275	9" LENGTH, 275 LB/INCH, TRAVEL = 5.46	124.00
VAS 21-09300	9" LENGTH, 310 LB/INCH, TRAVEL = 5.57	124.00
VAS 21-09350	9" LENGTH, 350 LB/INCH, TRAVEL = 5.17	124.00
VAS 21-09400	9" LENGTH, 400 LB/INCH, TRAVEL = 5.07	124.00
VAS 21-09450	9" LENGTH, 450 LB/INCH, TRAVEL = 4.90	124.00
VAS 21-09500	9" LENGTH, 500 LB/INCH, TRAVEL = 4.77	124.00
VAS 21-09550	9" LENGTH, 550 LB/INCH, TRAVEL = 5.06	124.00
VAS 21-09600	9" LENGTH, 600 LB/INCH, TRAVEL = 4.41	124.00
VAS 21-09675	9" LENGTH, 675 LB/INCH, TRAVEL = 4.80	124.00
VAS 21-09750	9" LENGTH, 750 LB/INCH, TRAVEL = 4.24	124.00

## ■ Billet Spring Seat Hardware

**Upper Spring Seats** – Coil-over-shock upper seats feature an open slot that allows the spring to be easily installed or replaced without removing the upper mounting eye.

**Lower Spring Seat** – The one-piece lower spring seat rides on the shock-body ACME threads and is used to adjust spring preload. Each seat features two spring-loaded, ball-lock mechanisms to securely hold the adjusted setting. When rotated, the ball-locks and shock-body grooves provide positive-click stops to audibly and physically notify you of every half-turn. The lock mechanism is easily operated using a common 5/32" allen wrench to tighten (lock) or loosen (unlock) the spring seat's two set screws. The lower spring seat also features six individual notches that enable the VariShock four-tang spanner wrench to interlock with the spring seat for slip-free adjustment. Upper and lower spring seats are anodized for surface hardening and improved appearance.



# Terms and Conditions

---

## ■ ORDERING

**Business Hours:** We are open from 7:00 a.m. to 5:30 p.m. , Pacific Time, Monday through Friday, and 8:00 a.m. to 1:00 p.m. Saturday. Call (800) 722-2269 for ordering only; tech support by email only: tech@CACHassisworks.com. Our 24-hour fax number is (916) 388-0295.

**Mail Orders:** When submitting your order by mail, please provide the following information: name, billing address, shipping address, phone numbers, e-mail address, complete part numbers, quantities, and any special instructions.

**Credit Card Orders:** We accept Visa, MasterCard, Discover Card and American Express. Please have your credit card and the billing address available. In order to protect you and us from credit-card fraud, all credit-card orders must be shipped to the credit-card billing address or creditor authorized shipping address. Many credit card companies allow multiple shipping addresses. If necessary, you may need to call your Issuing Bank and establish your "ship-to" address. All freight charges will be added to your shipment (except for truck shipments). Customer is responsible for all costs due to refused or missed shipments.

**Foreign Orders:** All foreign orders must be fully prepaid (including freight) in U.S. funds. Required duties and taxes are not the responsibility of Chassisworks and must be paid by the customer to the appropriate parties.

---

## ■ SHIPPING

All of our roll bars, roll cages, chassis, and welded clips are shipped by LTL truck, freight collect. Most other shipments can be sent by a small-package carrier — ground service. Available air-delivery options include: next-day service, 2-day service, 3-day service, or deferred air service to Alaska , Hawaii & Puerto Rico (combination of air and ground). You must inform us if you want your shipment by air service. Additional shipping fees will be applied to your order.

**Truck:** All truck shipments must be 100-percent prepaid. The shipment will go collect for the freight charges only. When receiving freight via truck, it is the customer's responsibility to verify that he/she is receiving all parts listed on the bill of lading and that all parts received are in good condition. If you sign for something you do not receive, neither the freight company nor Chassisworks/KP Components/Total Control Products/VariShock will be responsible for replacing the item.

---

## ■ RETURNS

No returns accepted after 30 days from date of invoice. We will only accept a return on a part that has not been modified, is still in its original package, and is in like-new condition. You will be charged a 25-percent restocking fee on any returned goods. And you will be issued a credit with us for the balance of the price you paid for the returned part. Before returning a part, you must call us. You will be given a "Return Authorization Number" (RA#), which you must write on the outside of the box being returned. A copy of the original invoice must be included. All shipping charges on return packages must be prepaid; we will not accept a C.O.D. If, upon examination, all parts are returned and all parts are in a like-new condition, a credit will be issued less the 25-percent restocking fee. No returns on special-order parts (including, but not limited to, axles, FAB9 housings, fiberglass, chassis, welded frames, any part made or ordered to customer specs, etc.). Springs are a tuning item and cannot be returned unless defective.

**Back Orders:** If any parts are back-ordered, they will be so noted on the invoice. Unless notified otherwise, we will ship the back-ordered parts as soon as they become available.

---

## ■ FREIGHT CLAIMS

All claims for damages, shortage, or loss must be made immediately with the carrier (i.e., UPS or the freight line). You must note any substantial damage to a package upon receipt of the shipment with the carrier. You may reorder any missing pieces from us. We will send you an invoice for the reordered parts, and you can use this invoice as proof to the carrier of replacement costs. Unfortunately, we cannot make these freight claims for you; however, if we can be of any assistance, please feel free to give us a call.

**Missing Pieces:** Although every effort is made to ensure that each part is packaged complete, inevitably, a component may be missing. You must check each kit as soon as you receive it against the parts list which is enclosed with each part. Any shortage must be reported immediately upon receipt of the product. Claims made after 10 days will not be honored.

---

## ■ WARRANTY NOTICE

There are NO WARRANTIES, either expressed or implied. Neither the seller nor manufacturer will be liable for any loss, damage or injury, either direct or indirect, arising from the use or inability to determine the appropriate use of any product. Before any attempt at installation, all drawings and/or instruction sheets should be completely reviewed to determine the suitability of the product for its intended use. In this connection, the user assumes all responsibility and risk. We reserve the right to change specification without notice. Further, Chris Alston's Chassisworks, Inc., makes NO GUARANTEE in reference to any specific class legality of any component. ALL PRODUCTS ARE INTENDED FOR RACING AND OFF-ROAD USE AND MAY NOT BE LEGALLY USED ON THE HIGHWAY. The products offered for sale are true race-car components and, in all cases, require some fabrication skill. NO PRODUCT OR SERVICE IS DESIGNED OR INTENDED TO PREVENT INJURY OR DEATH.

---

## ■ PRODUCT COLORS

Many of the items herein are colored for display purposes only. Your merchandise may arrive as bare metal, or in some finish other than that displayed in this catalog. Please read individual product descriptions for specifics on available finishes and/or discuss with your sales representative.

ALL PRICES ARE SUBJECT TO CHANGE.

Revised: 04/01/13

The most current version of our terms can be viewed at the Chassisworks website — [www.CACHassisworks.com/cac\\_terms.html](http://www.CACHassisworks.com/cac_terms.html).

