

READ ALL INSTRUCTIONS COMPLETELY AND THOROUGHLY UNDERSTAND THEM BEFORE DOING ANYTHING.  
CONTACT CHASSISWORKS TECH SUPPORT IF YOU NEED ASSISTANCE.  
(916) 388-0288 OR SALES@CACHASSISWORKS.COM

## INSTALLATION GUIDE

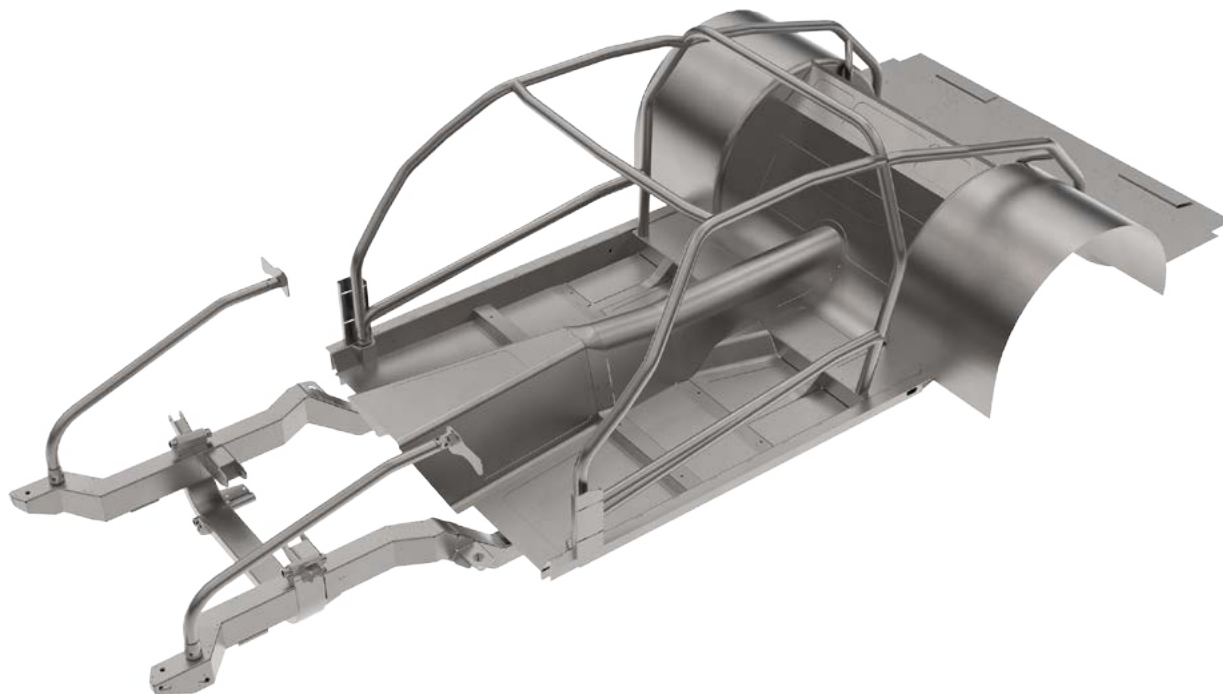

### 774X-F20 gStreet Chassis - '70-81 Camaro



**Description:** gStreet Chassis for 1970-81 Camaro and Firebird - Includes following suspension styles:  
Canted 4-Link, Torque Arm, Coil-Over IRS and Rocker Arm IRS.

- SPECIAL ORDER PART NOT RETURNABLE FOR ANY REASON -

# Table of Contents

## Specific Images – Camaro 1970-81

1. Rear Valance Landing .....	3
2. Rear Rocker Lip.....	5
3. Rear Strut Support.....	7
4. Wheel Tubs.....	10
5. Trunk Floor .....	14
6. Rear Firewall .....	15

## Assembly Drawings

34. Canted 4-Link Chassis .....	124
35. Canted 4-Link Chassis - Rear Floor .....	129
36. Coil-Over IRS Chassis.....	130
37. Rocker-Arm IRS Chassis.....	135
38. IRS Chassis - Rear Floor.....	140
39. All Chassis Styles - Front Floor .....	141
40. NOTES .....	142

## Reference Images – Camaro 1967-69

7. Stock Body .....	17
8. Body Fixture .....	18
9. Floor Removal .....	24
10. Rocker Removal .....	28
11. Rocker Install.....	31
12. Rear Frame Position.....	39
13. Frame Assembly .....	48
14. Subframe Alignment .....	50
15. Seat Pan.....	53
16. Forward Strut.....	55
17. Roll Bar.....	60
18. Roll Cage.....	69
19. Tunnel.....	73
20. Mid Tunnel.....	80
21. Front Floor.....	81
22. Mid Floor.....	86
23. Rear Panel.....	88
24. Rear Floor.....	90
25. Wheel Tubs.....	94
26. Trunk Floor .....	99
27. Rear Firewall .....	100
28. Fuel Tank .....	102
29. Complete Interior .....	104
30. Front Suspension .....	106
31. Rear Suspension .....	108
32. Complete Exterior .....	112
33. Scanning.....	114

# gStreet Chassis Guide – Camaro 1970-81

## Specific Images – Camaro 1970-81

### Rear Valance Landing

- 010-RearValanceLanding-001.jpg  
The formed sheetmetal landing is positioned against the rear valance area from the inside of the trunk. It provides a flat attachment point for the rear frame rail and floor panels, while also improving structural support at the far corners of the body.



- 010-RearValanceLanding-002.jpg  
The bottom corner of the landing intersects the factory sheet metal that angles away from the tail lamp panel. These are notched to allow the landing to fit tighter into the corner, minimizing any gaps.



- 010-RearValanceLanding-003.jpg  
Weld the two sides that wrap the corner of the valance. The longer top and bottom edges must be stitch welded prior to positioning the rear frame.



- 010-RearValanceLanding-004.jpg  
The rear frame position is dictated by the distance from the front suspension crossmember to the 4x2" crossmember of the rear frame. Refer to the assembly drawing for the correct dimension. You should be very close to the rear valance measurement shown in this image, but follow the drawing for final position.

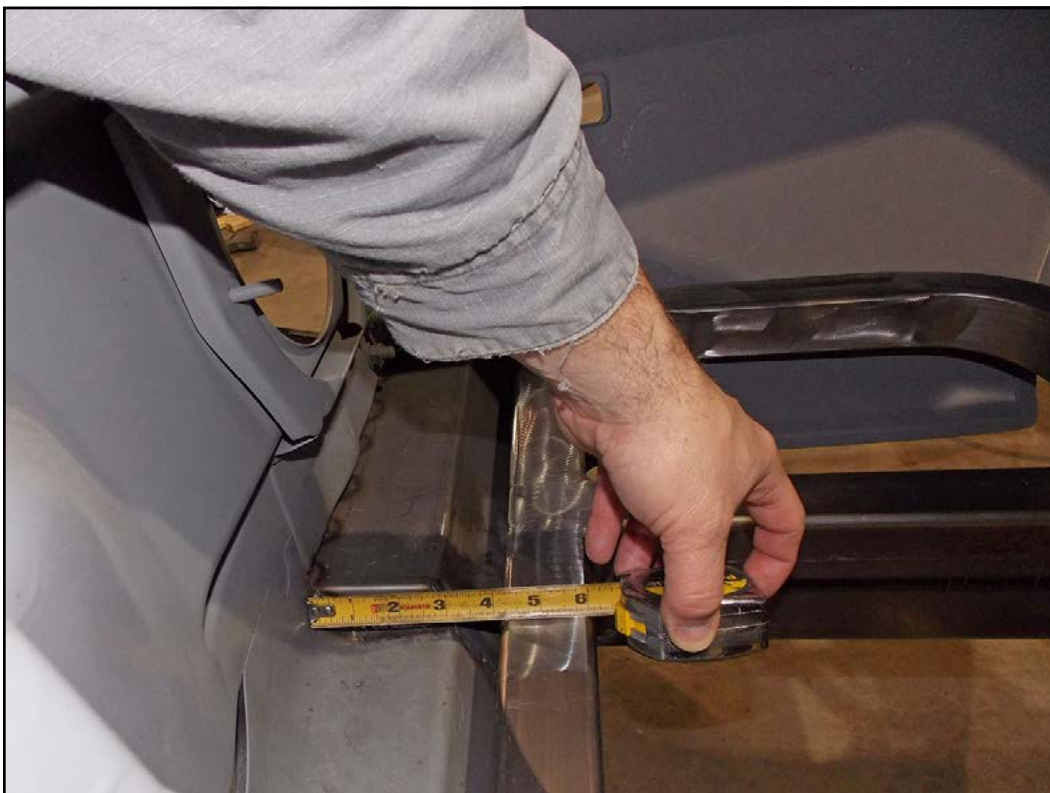

- 010-RearValanceLanding-005.jpg



## Rear Rocker Lip

- 020-RearRockerLip-001.jpg  
The notched end of the rocker seam rearward of the B-pillar door jamb flares outward and must be trimmed to properly attached to the gStreet chassis rocker.



- 020-RearRockerLip-002.jpg  
Measure and mark a line 12" from the end of the rocker seam.



- 020-RearRockerLip-003.jpg  
Use a cutoff wheel to cut along the top corner closest to the new gStreet rocker and remove the piece. The newly cut edge can be blended more easily into the rocker with a small fabricated strip.



## Rear Strut Support

- 030-RearStrutSupport-001.jpg

The corner lip of the rear deck must be trimmed in order to temporarily position the wheel tub inner wall. Use a straight edge and mark a line that is even with the outside edge of the frame rail. The cut should be a 1" radius to match the maximum tub height that is shown on the assembly drawing.



- 030-RearStrutSupport-002.jpg

Clamp the wheel tub wall against the frame rail. Wheel tub wall must be at correct height in relation to the frame rail. Refer to assembly drawing.



- 030-RearStrutSupport-003.jpg

Routing the rear roll-cage strut requires cutting an oversized hole outboard of the speaker hole. Hole position can be estimated by placing a level on top of the frame rail flush with the outer rail wall. The distance laterally to the strut will be the same at the rear deck bend and the strut landing on the 2x2" outrigger tube.



- 030-RearStrutSupport-004.jpg

The roughcut oversized hole can be seen in this image. A fill panel can be fabricated later by tracing the opening onto a piece of cardboard to create a template. With the strut correctly positioned, the support brace can be trimmed to fit. The wheel tub inner wall should be clamped into position for this step. Refer to the assembly drawing for the rail to top of tub dimension



- 030-RearStrutSupport-005.jpg  
The strut runs parallel to the frame rail. Strut support tube must clear wheel tub corner radius.



- 030-RearStrutSupport-006.jpg  
With the rear deck properly notched and the strut support tube in place we can move on to fitting the wheel tubs.



## Wheel Tubs



- 040-WheelTubs-001.jpg  
Referencing the assembly drawing, the tires can be put into position to verify clearance.



- 040-WheelTubs-002.jpg  
Check for adequate clearance during suspension compression.
- 040-WheelTubs-003.jpg  
Trace the wheel tub wall onto a piece of cardboard and cut out. This will be used to trim the body and



create a tub mockup for cutting the tub skin. Position the cardboard template at the correct height and position against the interior quarter panel.



- 040-WheelTubs-004.jpg  
Trace a the template onto the sheet metal. Cut cleanly along the marked line.
- 040-WheelTubs-005.jpg  
Clamp the cardboard template against the frame rail at the correct position, then measure the distance from the template to the quarter panel. A measurement should be made and marked at approximately one-inch increments. Measurements can then be transferred onto cardboard used for the outer skin.

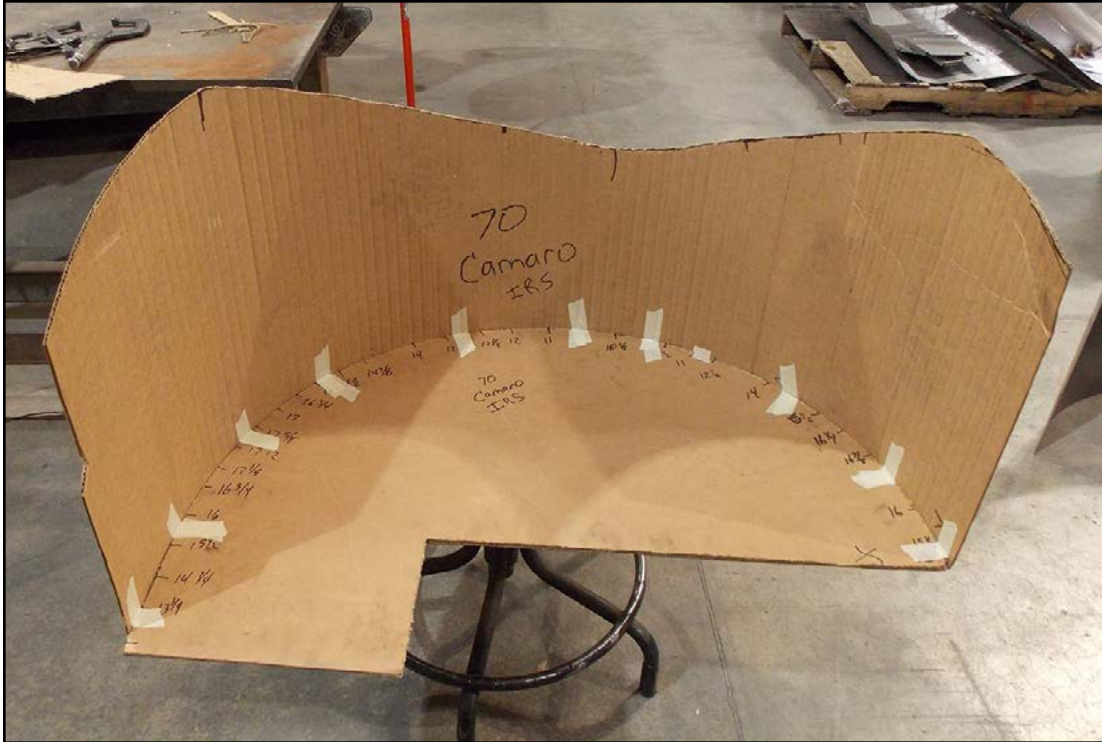

- 040-WheelTubs-006.jpg

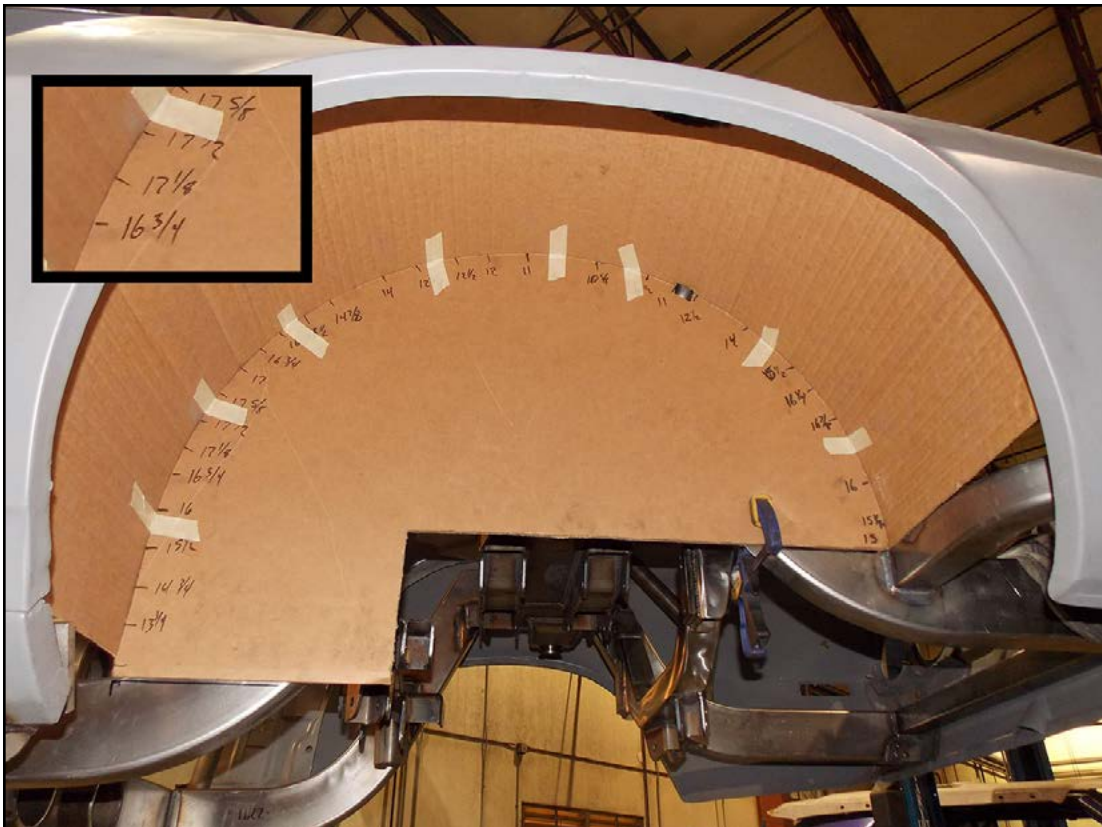

- 040-WheelTubs-007.jpg



- 040-WheelTubs-008.jpg



- 040-WheelTubs-009.jpg



## Trunk Floor

- 050-TruckFloor-001.jpg



- 050-TruckFloor-002.jpg



## Rear Firewall

- 060-RearFirewall-001.jpg



- 060-RearFirewall-002.jpg



# gStreet Chassis Guide – Camaro 1970-81

## Reference Images – Camaro 1967-69

### Stock Body

- 010-StockBody-001.jpg

We start with a Camaro body that is in decent shape. The body is stripped down to the bare unit-body. No need to worry about rusted floors since everything from the base of the firewall, below the pedals, to the tail light panel will be replaced. The panel that supports the upper part of the rear seat is also removed, leaving the rear deck intact.



- 010-StockBody-002.jpg

The entire trunk area up to the quarter panels and tail light panel is removed.



- 010-StockBody-003.jpg



## Body Fixture

- 020-BodyFixture-001.jpg  
Part of designing a builder friendly chassis system is providing the tools necessary to make the job easier. Chassisworks offers the gStreet chassis system for multiple vehicles so a modular shop friendly body fixture was designed. The fixture is a 4"-boxed tubing exoskeleton with interchangeable vehicle specific body mounts.

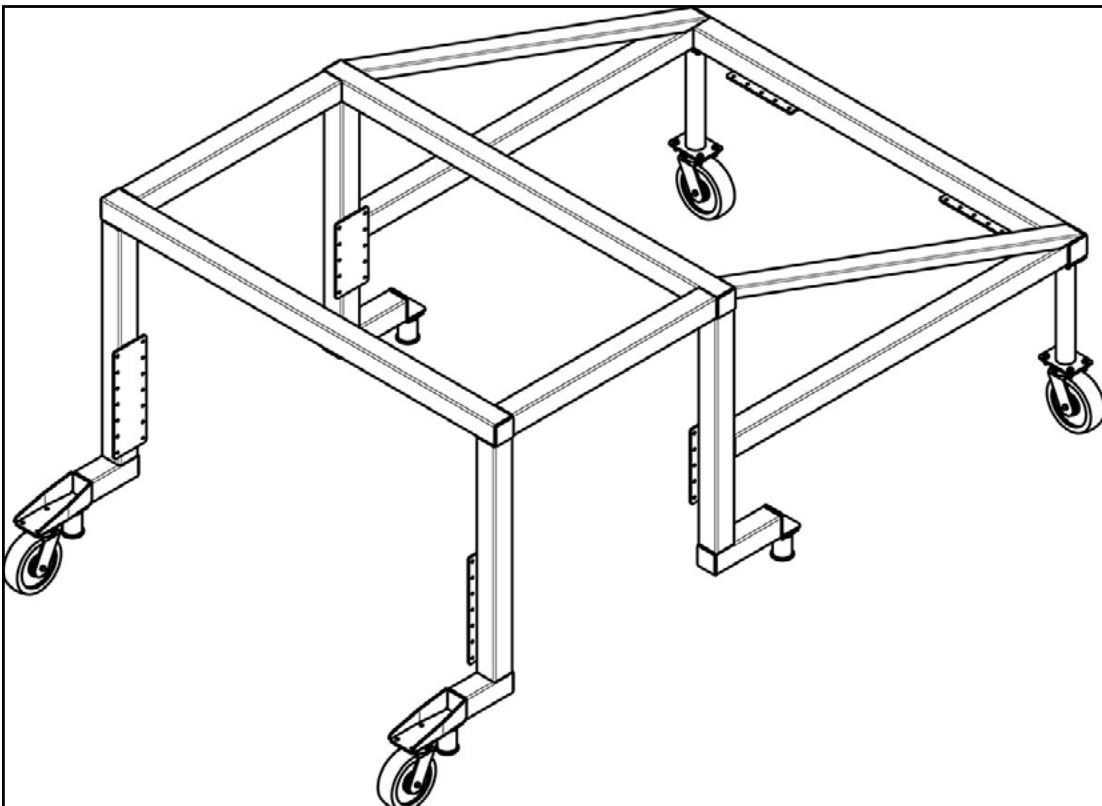

- 020-BodyFixture-002.jpg  
The fixture ships as an unassembled kit with detailed assembly diagram.

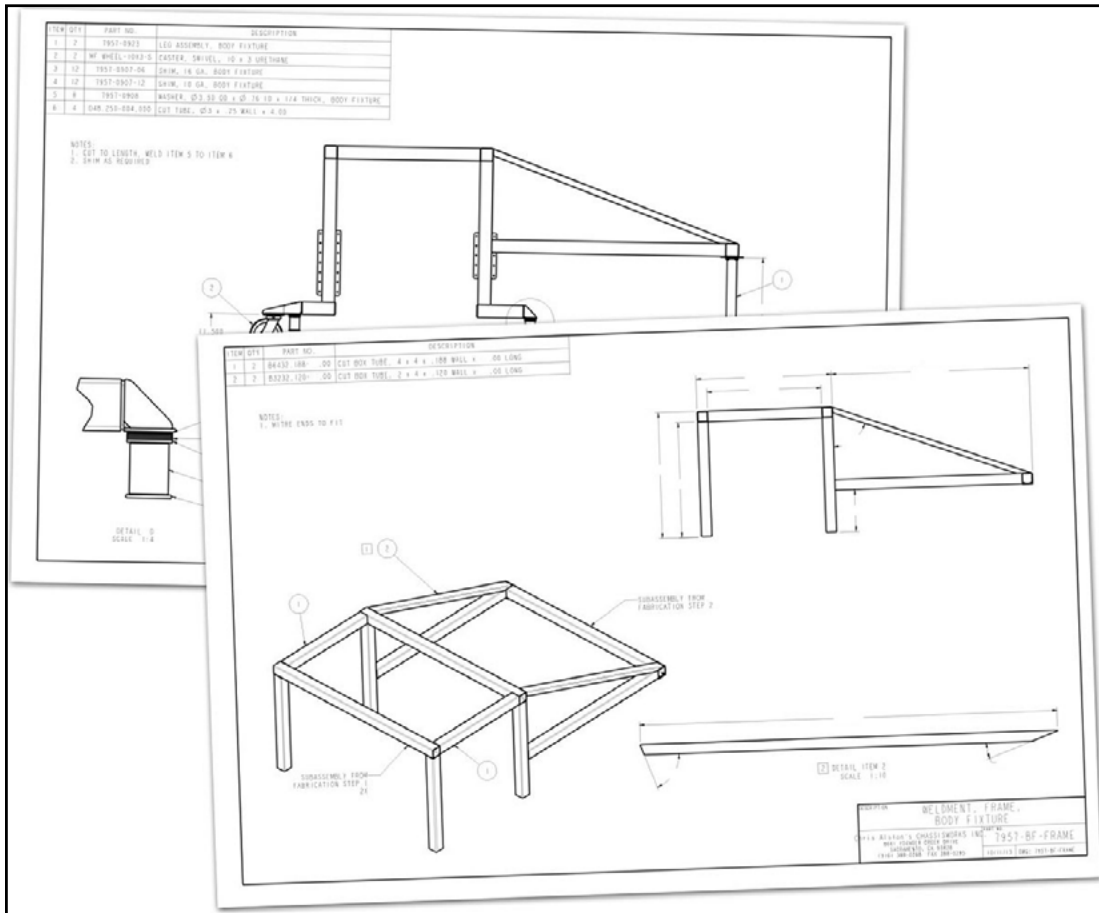

- 020-BodyFixture-003.jpg



- 020-BodyFixture-004.jpg  
Each leg of the fixture mounts to the arms of a common two-post lift. Spacer tubes and shims are used to level the fixture. The front legs of the fixture have an extended mounting area for optional casters, which allow the body to be moved from the lift without unbolting it from the fixture.



- 020-BodyFixture-005.jpg  
The fixture is securely mounted to the lift and ready for the body to be moved into position.



- 020-BodyFixture-006.jpg



- 020-BodyFixture-007.jpg  
Once in position the fixture is lowered around the body.



- 020-BodyFixture-008.jpg



- 020-BodyFixture-009.jpg  
Vehicle specific body mounts bolt to the door hinge bosses and to the fixture plate. The plate has additional sets of holes to accommodate mounts for different model vehicles.



- 020-BodyFixture-010.jpg  
The door striker boss serves as the center mount for the body.



- 020-BodyFixture-011.jpg  
The bumper mounting bosses secure the rear body position.



- 020-BodyFixture-012.jpg  
Optional casters allow the fixture to be easily rolled even with the body bolted to it.



## Floor Removal

- 030-FloorRemoval-001.jpg  
The majority of the floor section can be removed in one piece. Front floors and tunnel are initially cut forward of the support ridge at the front seat mounts. The remaining front floor pieces are separated from the lowest, angled portion of the firewall by removing the factory spot welds. Trimming out the tunnel involves test fitting the replacement tunnel and is shown in more detail in a later step. Cut along the rockers, continuing through the wheel tubs into the trunk floor area.



- 030-FloorRemoval-002.jpg

Rear seat braces are cut one inch below the rear deck to leave a lip for attachment of the replacement panel. The outside edge of the wheel housing must be trimmed short and cleaned up for tire clearance. As the wheel housings are removed, the bottom edge of the hinge supports must be cut free. These can be tied back into the chassis after the new sheet metal and rear cage struts are installed.



- 030-FloorRemoval-003.jpg

The vertical panel that runs up to the trunk floor is often rusted through and can be completely cut out and replaced if needed. These were decent shape and were cut off two inches below the original trunk floor to make room for the rear frame's outriggers.



- 030-FloorRemoval-004.jpg

The original fuel filler access hole is deleted with the supplied sheet metal cap. The cap is welded and ground clean before the new frame is put into position.

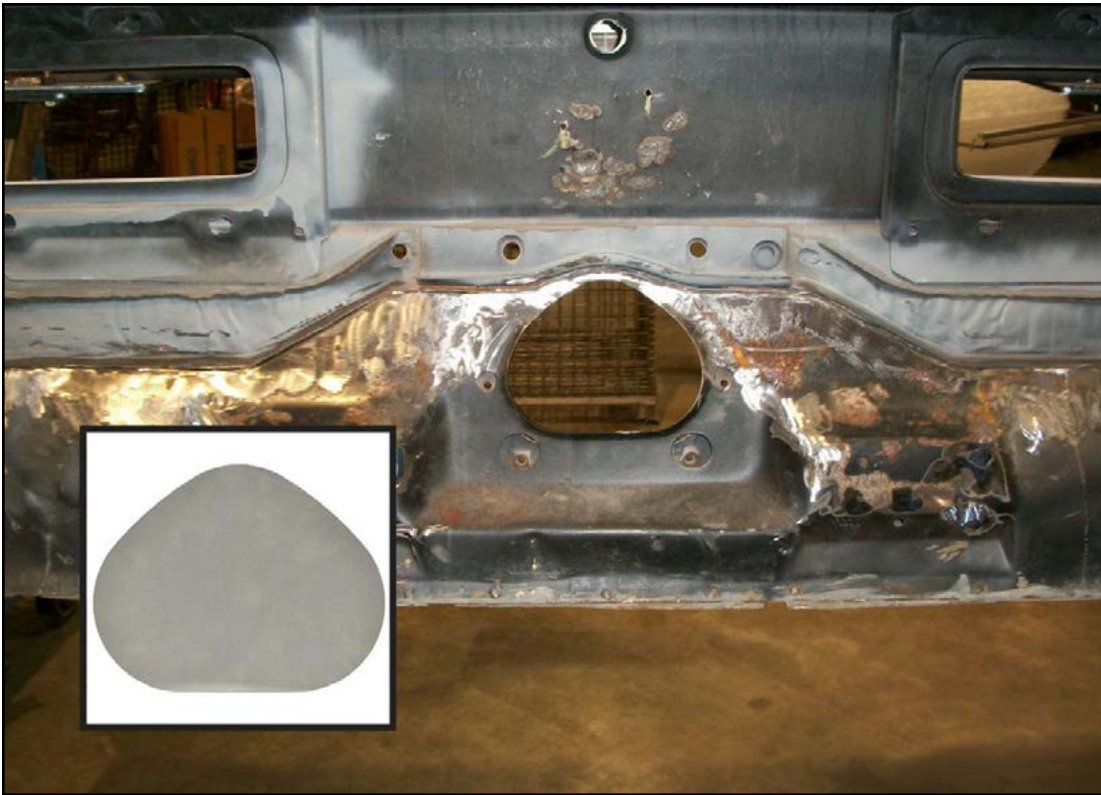

- 030-FloorRemoval-005.jpg



- 030-FloorRemoval-006.jpg

With the trunk, rear deck, and floor cleanly cut out we are ready to move on to replacing the rocker panels.



## Rocker Removal

- A significant amount of chassis strength and rigidity is gained by installing the prefabricated double-wall rocker sections. The inside shell of the OEM rocker is removed, revealing the empty outer-body wall, and replaced with the heavier walled Chassisworks' rocker with boxed interior structure. Seat belt mounts and wiring access channels are built into the rockers to simplify final vehicle assembly. The improved rocker provides a far superior structure on which to mount the rear frame crossmember and roll bar or roll cage.
- 040-RockerRemoval-001.jpg  
The new rocker structures provide a stronger base for the roll cage and are tied into the new frame by the rear frame crossmember and fabricated seat mount assembly. Access holes at each end of the rockers allow wiring or plumbing to be cleanly and safely routed through the chassis, exiting forward of the firewall.



**NOTE: Replacement rocker structures will differ slightly from those shown in the following images.**

- 040-RockerRemoval-002.jpg



- 040-RockerRemoval-003.jpg  
A horizontal cut line is marked just above the bottom panel of the original rocker. It is important to cut above the bottom panel so as not to remove the lip.



- 040-RockerRemoval-004.jpg  
The top cut is made vertically along the inside corner where the top panel meets the vertical edge of the doorsill. The new rocker will seat against the corner at the same height as the original.



- 040-RockerRemoval-005.jpg  
A template can be traced off the rear end of the new rocker to establish the angled cut line at the wheel-housing end.



- 040-RockerRemoval-006.jpg  
There are multiple panels to cut in order to extend the new rocker through the lower firewall.



## Rocker Install

- 050-RockerInstall-001.jpg  
At this point, the rocker is placed into position, aligned with the bottom rocker lip, and a straight edge used to mark the remaining cuts.



- 050-RockerInstall-002.jpg  
The rear end of the rocker should sit flush with the remaining corner of the wheel housing.



- 050-RockerInstall-003.jpg  
Clamps are used to hold the position while the passenger side of the body is completed to this same point.



- 050-RockerInstall-004.jpg



- 050-RockerInstall-005.jpg  
The new chassis, including the rockers, are aligned in reference to the front subframe alignment pin holes on the engine side of the firewall.



- 050-RockerInstall-006.jpg  
A bolt threaded into the Chassisworks alignment pin extends the reference point closer to the rocker.



- 050-RockerInstall-007.jpg

A level ensures the pin is square before measuring to the leading edge of the rocker. The opposite rocker is then positioned at the same measurement before tack welding into place.



- 050-RockerInstall-008.jpg

The rear edge of both rockers should be close to flush with the original wheel housings.



- 050-RockerInstall-009.jpg  
There are multiple rosette holes predrilled along the lower flange of each panel. Clamps are used to hold factory and new flanges together while plug welding them together.

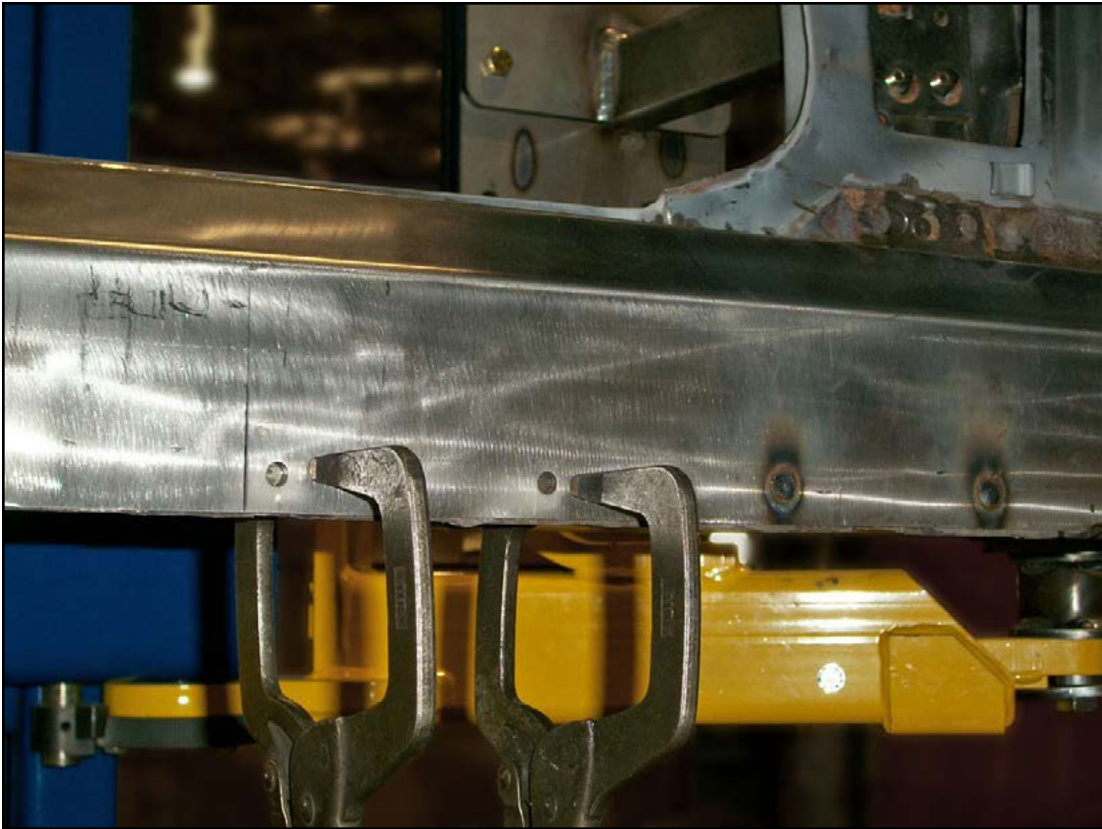

- 050-RockerInstall-010.jpg  
One-inch stitch welds are used along the length of the top edge. The lower firewall and rear wheel housing are left unwelded at this time.



- 050-RockerInstall-011.jpg

At this point, a scotch-brite disc is used to clean up the welds and removed the paint from the areas where the roll cage main hoop and side bar will mount.



- 050-RockerInstall-012.jpg

In addition to the boxed rail that runs through the rocker, gussets are welded in place to strengthen the structure alongside the landing areas for the roll cage. This gusset plate follows the contour at the base of the B-pillar.



- 050-RockerInstall-013.jpg



- 050-RockerInstall-014.jpg  
The A-pillar gusset supports the cage side bar mounting area. Both gusset plates are welded completely around all outside edges.



- 050-RockerInstall-015.jpg  
Screw-on cover plates are included for easier access when routing lines or wiring.



- 050-RockerInstall-016.jpg  
The forward end of the rocker now extends through the firewall and is supported with a folded gusset. It is important to securely anchor this end of the rocker, so all seams in this area must be completely welded.



- 050-RockerInstall-017.jpg  
With this portion of the installation complete, we now move on to the rear frame.



## Rear Frame Position

- 060-RearFramePosition-001.jpg



- 060-RearFramePosition-002.jpg



- 060-RearFramePosition-003.jpg

Chassisworks' canted 4-bar Camaro rear frame system is a truly versatile high-performance suspension solution, suitable for high-power, big-tire, pro-touring projects that require more strength and stiffness than systems mounted to the OEM sheet metal can provide. Achieving a very low rocker ground-clearance height of 4" with massive rear tires was one of the system goals. We are proud to state that nearly all of the normally 'one off' chassis and sheet metal fabrication that is required to tuck extremely large tires, drivetrain, and exhaust into your Camaro is expertly built into a neatly packaged 'off the shelf' system. To ensure perfect geometry and fit with minimal effort while saving considerable installation time, rear frames including front crossmember ship as a factory-welded subassembly with unattached 2 x 2" trunk outriggers and 3 x 2" front subframe connectors for easier installation. The 4 x 2 x .120"-wall rear frame is designed with minimal rise over the rearend housing and maximum clearance above the driveshaft and third-member to allow more room in the rear seat and trunk areas without sacrificing suspension travel.



- 060-RearFramePosition-004.jpg

The rear frame crossmember meets the rocker at the reinforced B-pillar area. Each end of the crossmember is pre-cut to fit the rocker contour and should be a very close match to the width between the rockers.



- 060-RearFramePosition-005.jpg

The included assembly diagram illustrates that the front bottom corner of the crossmember is positioned 56-5/8" from the center of the alignment pin and 3/8" above the rocker lip. This leaves room for the rear floor pieces to sit on top of the crossmember tube and just below the top edge of the rocker.

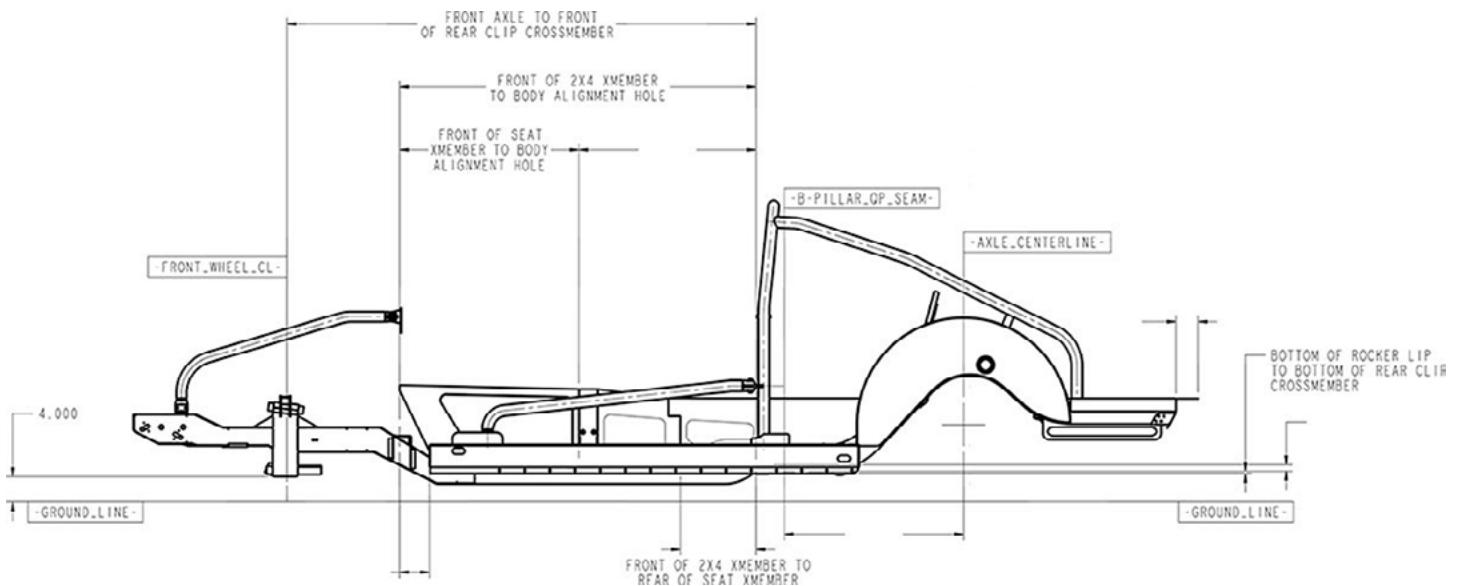

- 060-RearFramePosition-006.jpg  
Measuring from the inside of each frame rail, the rear frame should match up to the center of the tail light panel.



- 060-RearFramePosition-007.jpg  
The height of the frame is set equal to the lower layer of sheet metal where the rear valance and rail light panel meet. The floor tin will rest on this edge.



- 060-RearFramePosition-008.jpg  
Ideally, the body and chassis will be level to one another. If inconsistencies are found, the body must be made square to the new chassis.



- 060-RearFramePosition-009.jpg  
Two-inch square outriggers support the trunk floor and secure the lower rear quarter-panel position. In this installation, the factory sheet metal is in good condition and is trimmed to support the outer frame.



- 060-RearFramePosition-010.jpg  
Prefomed brackets, included with the system, anchor the frame rail to the rear valance.



- 060-RearFramePosition-011.jpg



- 060-RearFramePosition-012.jpg  
Once the frame position is verified to be absolutely correct, all attachment points are welded.



- 060-RearFramePosition-013.jpg
- 060-RearFramePosition-014.jpg  
The gStreet fuel tank system omits the factory filler neck. A fill plate is included and must be welded in before placing the trunk floor pieces.



- 060-RearFramePosition-015.jpg
- 060-RearFramePosition-016.jpg  
Three separate trim pieces are used to close off the space between the frame and tail lamp panel. The folded edge sits squarely against the frame.



- 060-RearFramePosition-017.jpg  
The unfolded edges of the trim pieces are completely welded, while the stronger folded edge is stitch welded to the frame.



- 060-RearFramePosition-018.jpg



- 060-RearFramePosition-019.jpg  
Positioning and securing of the rear to the body is complete.



## Frame Assembly

- Similar in construction technique to Chassisworks original Camaro subframe, the enhanced gStreet subframe features redesigned fabricated frame rails to increase maximum tire section width from 285 to larger 305-wide (12.25") tires. Engine mounts are also repositioned rearward, improving weight distribution, and leveled to provide bellhousing, transmission and exhaust ground clearance for the significantly lower ride height of the complete frame system.
- 070-FrameAssembly-001.jpg  
The front frame rails and crossmember assembly arrives pre-welded with the subframe connectors shipped separately for easier installation.



- 070-FrameAssembly-002.jpg  
The frame rail and crossmember intersection features a multi-layered, boxed construction technique to maximize strength in this critical area. An additional folded gusset brace reinforces the upper control arm mount to accommodate the increased forces generated by larger tires.



- 070-FrameAssembly-003.jpg

This outside view shows the single-piece, bent crossmember, which holds the mounts for the upper and lower control arms, and rack & pinion unit.

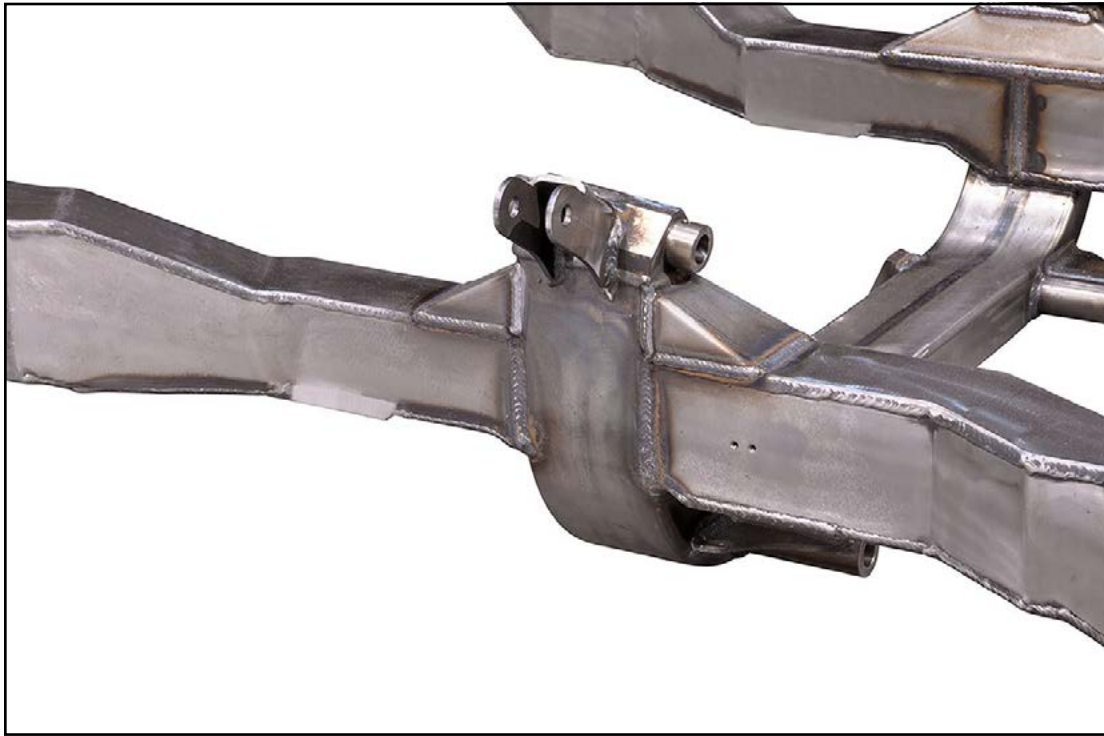

- 070-FrameAssembly-004.jpg

When fully assembled within the body, the gStreet chassis creates a full-length frame with the boxed rockers and roll cage adding significant torsional stiffness.



## Subframe Alignment

- During this step, the crossmember must be supported by a jack stand at the front crossmember throughout installation of the 3x2" subframe connectors and seat pan assembly. With the body bushings between the sub frame mounting tabs and the body, adjust or shim the jack stand to level the frame rails. They must sit parallel to the rockers.

- 080-SubframeAlignment-001.jpg

To ensure that the subframe is squarely aligned with the body a Chassisworks alignment pin is used exactly in the same way as the factory subframe was installed.

- 080-SubframeAlignment-002.jpg

With the subframe in the correct position the mounting bolts are tightened to hold it while measurements are taken to double check the alignment.

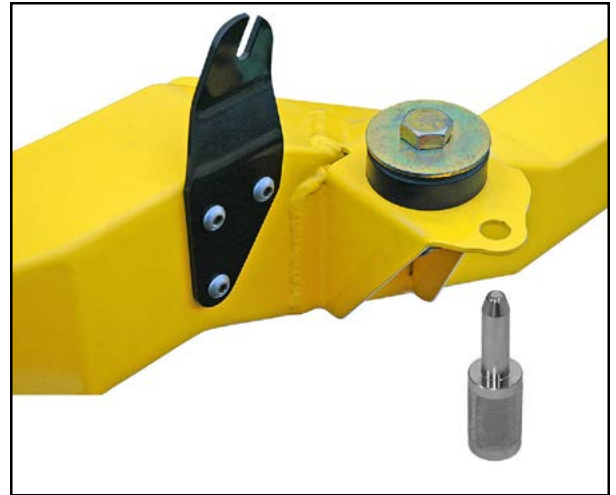

- 080-SubframeAlignment-003.jpg



- 080-SubframeAlignment-004.jpg



- 080-SubframeAlignment-005.jpg

The diagonal measurement from the factory tab that extends from the firewall just above the body bushing to the forward threaded hole on the opposite frame horn is taken, then compared to the measurement from the opposing diagonal. These measurements must match.



- 080-SubframeAlignment-006.jpg  
At this point the 3x2" subframe connectors fit and seat pan and be fit and tacked into position.



- 080-SubframeAlignment-007.jpg  
The subframe connectors insert into the back of each fabricated frame rail and connect to the rear suspension crossmember. The inside distance between the subframe connectors should be 31-3/4". The subframe connectors and seat pan must be fit simultaneously to ensure that the pieces align correctly. Some trimming of the seat pan edges may be required due to variances in vehicle bodies affecting the rocker width.



## Seat Pan

- Manually fabricating the seat mount area can be an extremely difficult and time consuming. Seating position, overall rigidity of the area, strength of the mounting bosses, and adequate drivetrain clearance are all extremely important for safety and comfort. Chassisworks addresses these issues with a factory-welded assembly that includes integrated seat and safety harness mounting locations.

- 090-SeatPan-001.jpg



- 090-SeatPan-002.jpg

To improve driver comfort the seating position is lowered 1" by notching the rear seat-pan support, providing additional headroom and increased visibility below the windshield brace.



- 090-SeatPan-003.jpg

The front support brace houses reinforced mounting holes for the fabricated transmission cradle.



- 090-SeatPan-004.jpg

The transmission cradle mount is an important component for maximizing ground clearance. All mounts and hardware sit above the frame rails, leaving more room for the exhaust. The cradle incorporates mounts for the drive shaft loop, transmission mount bushing, and optional torque arm rear suspension, which mounts underneath the cradle plate.



- 090-SeatPan-005.jpg

Here you can see that the cradle fits tight to the tailshaft of the transmission instead of hanging below the urethane mount as a traditional cross member does.

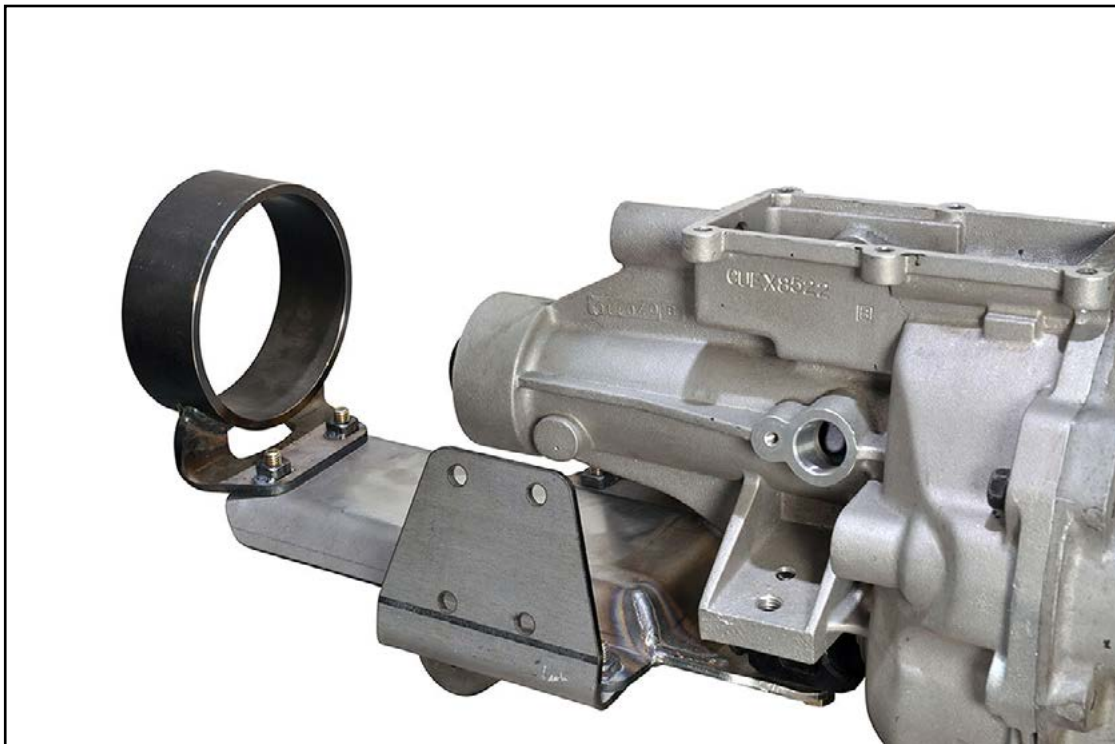

## Forward Strut

- Adding tubular struts between the factory upper firewall area and subframe triangulates the front clip, virtually eliminating chassis deflection forward of the firewall.
- 100-ForwardStrut-001.jpg  
To ensure a structurally secure mount, reinforcement plates and mounting tabs weld directly to the firewall at the fender mount, the most rigid part of the firewall.



- The lower end of the support strut utilizes Chassisworks' exclusive bolt-together Gemini connector system.
- Our in-house-engineered Gemini system is used to connect the strut to the subframe, enabling an easy-to assemble, precision slip-fit joint that is substantially stronger than a welded joint.
- Installation of the strut and mounts requires minor trimming and welding for individual fit, but can later be unbolted to facilitate regular maintenance or subframe removal.

- 100-ForwardStrut-002.jpg  
The flat plate follows the contours of the firewall. Measure from the bolt hole to the edge of the plate sure both sides are positioned the same.



- 100-ForwardStrut-003.jpg  
The mounting tabs must be perpendicular ground so that the strut can be lifted straight up for removal later, if needed.



- 100-ForwardStrut-004.jpg  
Tabs are positioned one inch from the edge of the fire wall plate. For now, each component is tack welded until the entire strut bar assembly fits and is positioned correctly.



- 100-ForwardStrut-005.jpg  
The Gemini connector is made up of a base that welds to the flat area of the frame horn and a receiver tube end. With the strut tube and hardware slipped together the Gemini base position can be finalized and tack welded to the frame horn.



- 100-ForwardStrut-006.jpg  
Strength of the forward strut is critical to chassis rigidity so all fixed joints are welded completely around.



- 100-ForwardStrut-007.jpg  
After welding, the clevis hole alignment may be slightly off. Use a round file to lightly clean up the edges without widening the hole.



- 100-ForwardStrut-008.jpg



- 100-ForwardStrut-009.jpg  
Still more to do, but the front end is now ready to handle significantly more horsepower and cornering forces than an OEM-based solution could ever hope to.



## Roll Bar

- 110-RollBar-001.jpg



- 110-RollBar-002.jpg

With the expected level of performance from vehicles built upon the gStreet chassis comes the requirement for additional safety and chassis strengthening. Customers have the option of installing a street-friendly roll bar or full roll cage for more complete protection. High-clearance cage sides, windshield brace, and rear struts makes the Exact-Fit roll cage an excellent choice for pro-touring performance applications when comfort and visibility still need to be considered. Cages are mandrel bent in a variety of steel tubing types, including 1-5/8 x .134" mild-steel, 1-5/8 x .083" 4130, 1-3/4 x .134" mild-steel, and SCCA compliant 1-3/4 x .125" DOM. The removable back brace with billet clevis ends comes standard. Door bars are included and can be installed at a 'street style', hip-height position for easier entry and exit from the vehicle, or positioned at a higher 'race style' position for increased driver protection. Optionally available hardware permits removal of door bars when greater access is required. Spring-loaded Faspins are standard removable bar hardware, with push-button L-handle locking pins and polished-stainless spud bolts offered as an upgrade option.



- 110-RollBar-003.jpg  
Installation begins with positioning of the main hoop. From the front edge of the rear frame crossmember, the main hoop is positioned 1.25" rearward.



- 110-RollBar-004.jpg  
This junction of the B-pillar, rear frame crossmember, and internal supporting walls of the rocker are purposely arranged to maximize rigidity at the base of the main hoop.

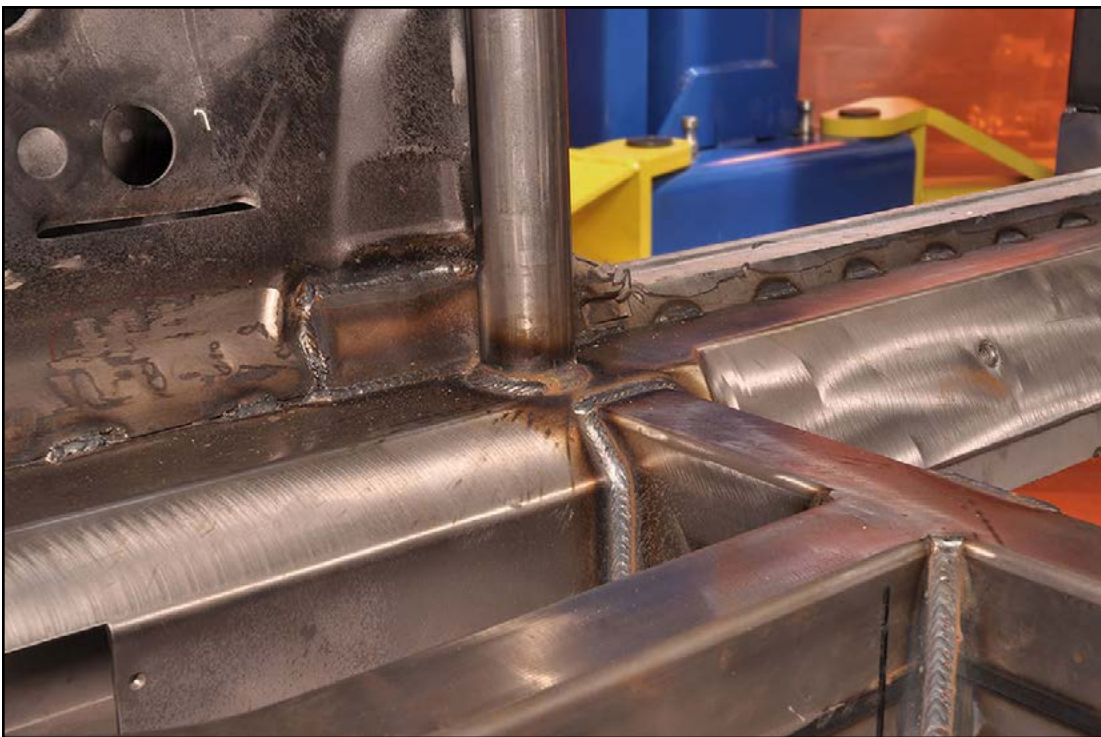

- 110-RollBar-005.jpg

Unlike a standard drag race roll cage, the rear struts attach to the main hoop outboard of the top bends and feature a short bend to route the tube above the window opening and tighter to the roof.



- 110-RollBar-006.jpg



- 110-RollBar-007.jpg

The strut continues through the existing slot in the rear deck. The slot is widened slightly to keep the tube as far outboard as possible, maintaining good visibility out the rear window.



- 110-RollBar-008.jpg



- 110-RollBar-009.jpg

Alignment of the rear strut tube falls just outside the frame rail and flush with the inside edge of the wheel tub. The fuel cell flange will rest on top of the frame rail so this area is left open.



- 110-RollBar-010.jpg



- 110-RollBar-011.jpg

For added support, a 1"-diameter tube mounts between the top of the rear frame and strut. The bend at the top is for clearance around the wheel tub.



- 110-RollBar-012.jpg

The rear hump sheet metal panel is notched for the support tube and must be in place to correctly position the tube. Use the fuel tank to find the position of the panel.



- 110-RollBar-013.jpg  
Chassisworks billet Gemini connectors and clevis ends are used to mount the side bars securely and allow removal, if ever needed.



- 110-RollBar-014.jpg  
The front end of the sidebar lands alongside the A-pillar and directly above the rocker panel's internal support.



- 110-RollBar-015.jpg

A 3/8"-thick mounting tab mounts horizontally on the main hoop for maximum strength against side impacts.



- 110-RollBar-016.jpg

Sidebar tubes are intentionally shipped slightly long to allow some variance in the height and angle of the bar. The bar should generally run somewhere between the driver's hip and shoulder, with consideration for interior and seat clearance, and ease of entry and exit from the vehicle.



- 110-RollBar-017.jpg

Similarly the back brace or harness bar is removable to increase comfort and usability when it is not required to safety purposes. The clevis tab mounts off the back side of the main hoop so as to not interfere with the front seats or access to the back seat area.



- 110-RollBar-018.jpg

This image really highlights how tight the main hoop and rear struts fit against the body. It would be extremely difficult to create the four compound bends in the rear struts without utilizing the complete 3D vehicle scan as part of the design process.



- 110-RollBar-019.jpg

With the roll back installed, this is the basic backbone of the gStreet chassis. This is a huge improvement over the multiple structural pieces underlying the factory sheet metal.

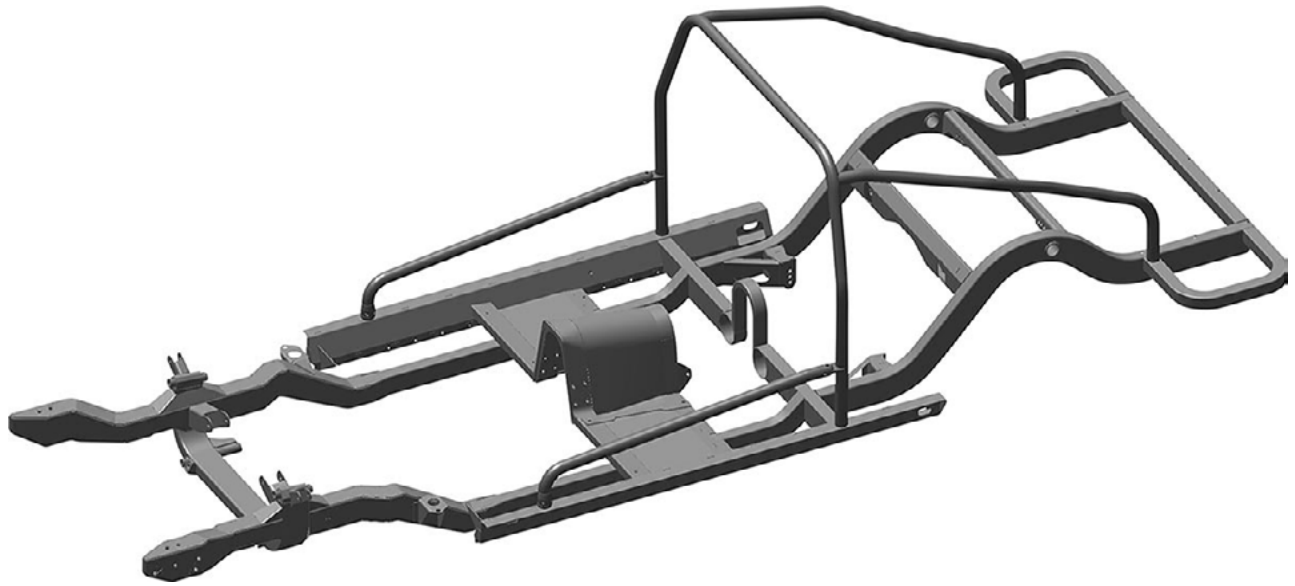

## Roll Cage

- 120-RollCage-001.jpg

To further improve chassis strength and safety the system can be optioned with full cage sides and windshield brace. This is highly recommended for vehicles that will see actual road course use or are outfitted with drivetrains in the 700 to 1000 horsepower range.



- 120-RollCage-002.jpg



- 120-RollCage-003.jpg

As is in the basic roll bar, tubes are routed tight against the body to be less of an obstruction and to maximize the driver's visibility. Room remains for installation of the headliner and interior trim pieces.

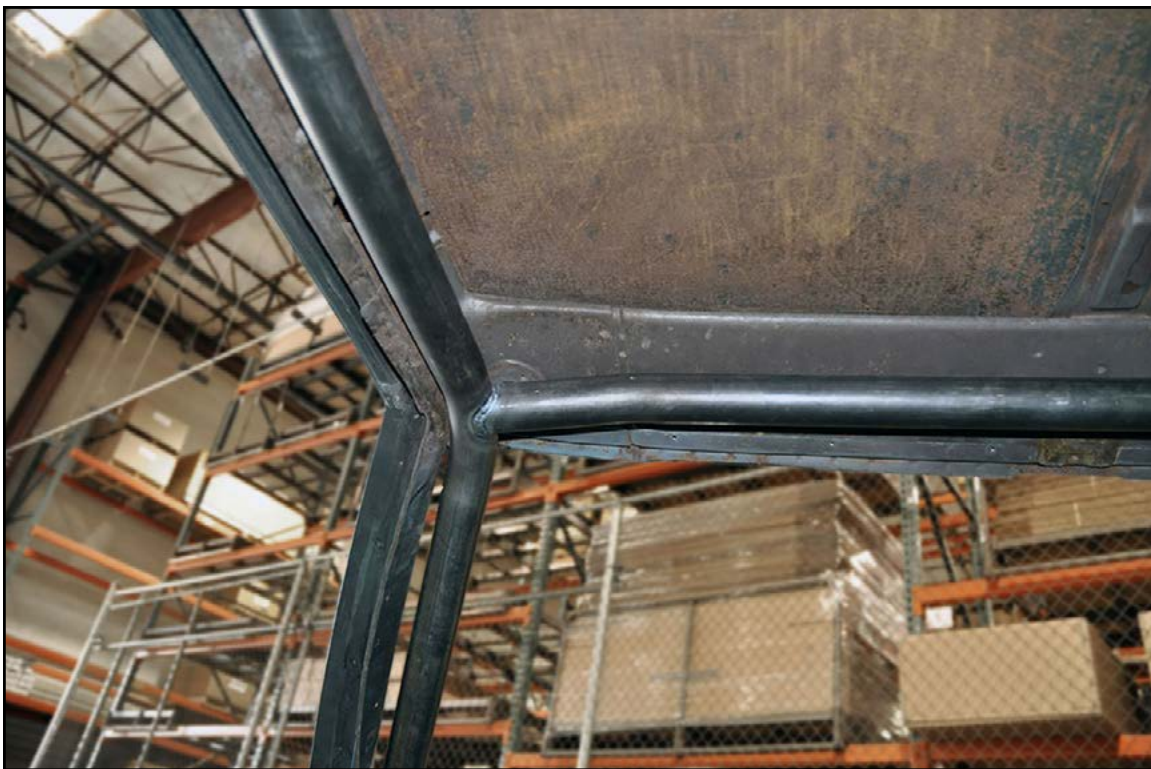

- 120-RollCage-004.jpg  
Multiple bends keep the cage side close to the front kick panels and as far forward as possible.



- 120-RollCage-005.jpg  
The factory dash structure is trimmed at each end to allow the cage side to pass through.

- 120-RollCage-006.jpg

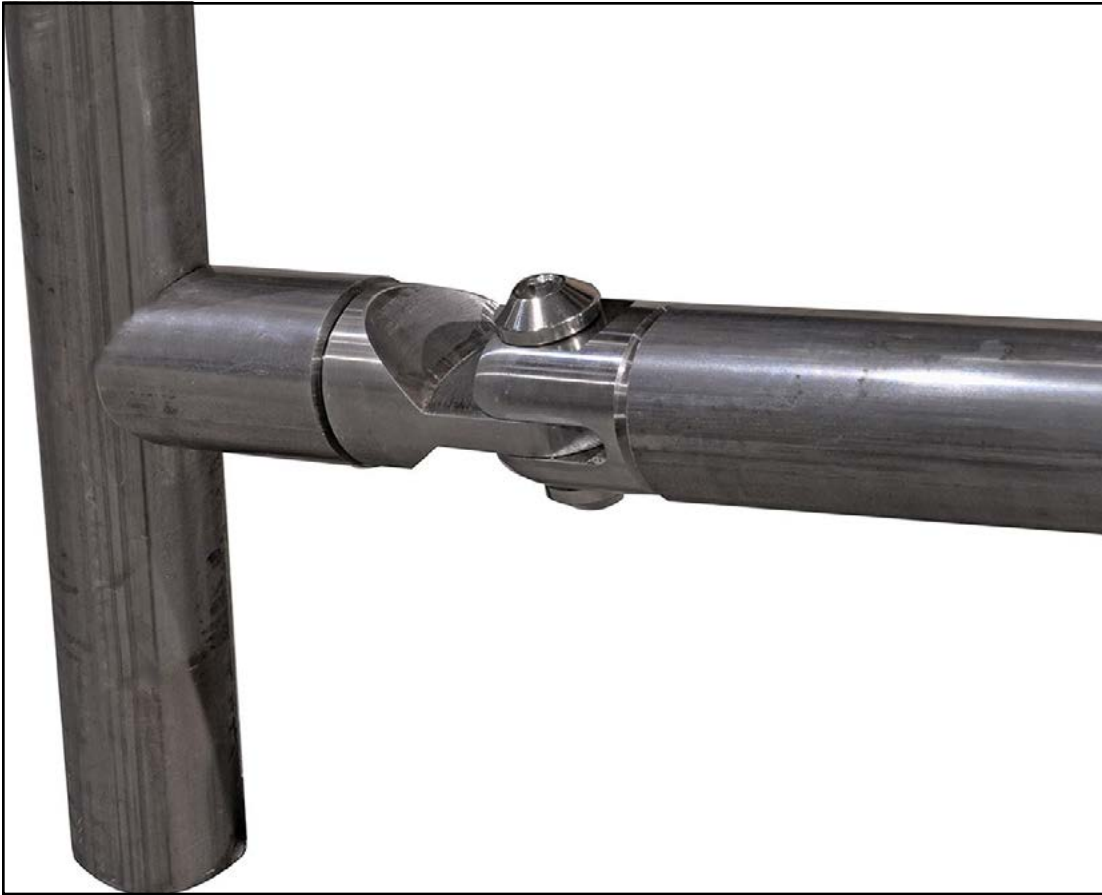

- 120-RollCage-007.jpg  
Optionally available hardware permits easy removal of the side bars. Removable hardware options include: spring-loaded faspins, quick-release ball lock L-handle pins, or polished stainless-steel spud bolts.



- 120-RollCage-008.jpg

In this completed installation the cage is configured for an extremely high-horsepowered street car. Cage sites are installed but the side bars are mounted low for easier access getting in and out of the vehicle . The headliner and interior rear quarter panels are already in place with a complete interior planned in the finished build.



## Tunnel

- The Camaro prefabricated floor kit replaces ALL floor and drivetrain-tunnel sheet metal from the base of the firewall to the rear tail lamp panel. Large sheet metal spans are bead-rolled to strengthen each panel, significantly reducing flex and vibration. To facilitate clean, rapid, and accurate installation, folded lips, inset lap joints, and plug weld holes are designed into each component.
- 130-Tunnel-001.jpg  
The forward tunnel section is taller and wider than the factory tunnel for clearance with the T-56 transmission and allows the drivetrain to be level so that all components sit above the bottom of the frame rails. At the rear and bottom flanges, lap joints are used where the tunnel meets the floor and seat pan assembly. The front opening of the tunnel mates with the cut out portion of the firewall and will need to be worked in order to achieve a smooth transition.

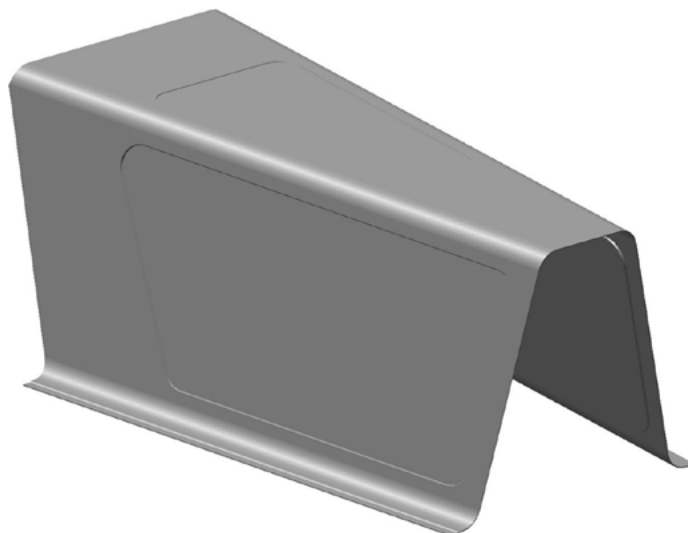

- 130-Tunnel-002.jpg  
Using the tunnel as a guide, the firewall is marked then cut approximately 1" long before test fitting and more trimming. Measurements are taken from both sides to mark the center of the firewall to align with the center of the tunnel



- 130-Tunnel-003.jpg  
The back of the tunnel seats into a lip feature on the face of the seat pan .



- 130-Tunnel-004.jpg  
The tunnel is held into position to verify fit from inside



- 130-Tunnel-005.jpg  
The seam at the tunnel and seat pan should be a tight parallel fit creating a slight rise toward the firewall.



- 130-Tunnel-006.jpg



- 130-Tunnel-007.jpg  
With the tunnel now at the correct height it can be marked for final trimming. The outside is marked following the angle and curvature of the firewall. This will also be a lapped joint for ease of assembly.



- 130-Tunnel-008.jpg  
After trimming, double check that the tunnel is in the right position before beginning final attachment.



- 130-Tunnel-009.jpg  
A hole is drilled through both pieces of metal and a cleco fastener used to hold them together while tack welding.



- 130-Tunnel-010.jpg  
Our first pass of tack welds begins at the center of the tunnel and runs out and down to the floor.



- 130-Tunnel-011.jpg  
The edges of the tunnel and base of the firewall each have a recessed flange that will support the front floor section.



- 130-Tunnel-012.jpg

The overhanging lip of the tunnel is hammered flat against the firewall before tack welding . You can see in this installation that the two sheets overlap approximately one inch.



- 130-Tunnel-013.jpg

Final welding will be done after the front floor pieces have been fit.



## Mid Tunnel

- 140-MidTunnel-001.jpg

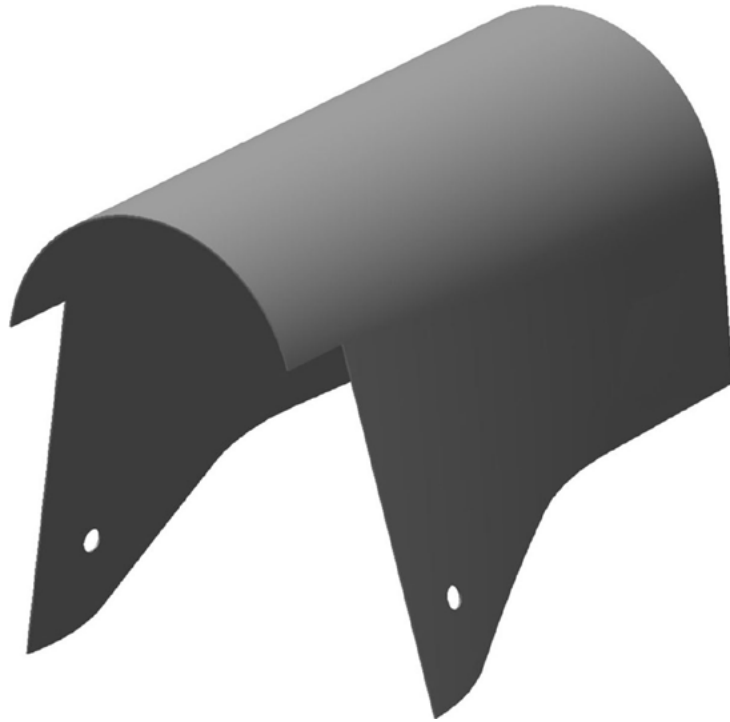

- 140-MidTunnel-002.jpg

The mid-tunnel section covers the area between the seat pan assembly and the rear frame crossmember. Positioning of this piece is basically a simple puzzle fit. An alignment hole matches up with the tabs that extend from the seat pan and the stepped front edge seats into the layered mating area for a completely flush fit. The back end covers half of the driveshaft tunnel and creates a ridge for the rear section of the tunnel to seat against.



## Front Floor

- 150-FrontFloor-001.jpg

Multiple features are designed into the floor pieces to simplify installation. The two edges that seat against the rocker and seat pan are bent and drilled to maintain a straight edge and facilitate plug welding the panel. The joint between the firewall and front tunnel will vary slightly affecting the length and width of the front floor panel. For this reason a couple of quick measurements are necessary to trim the panel to the correct size.

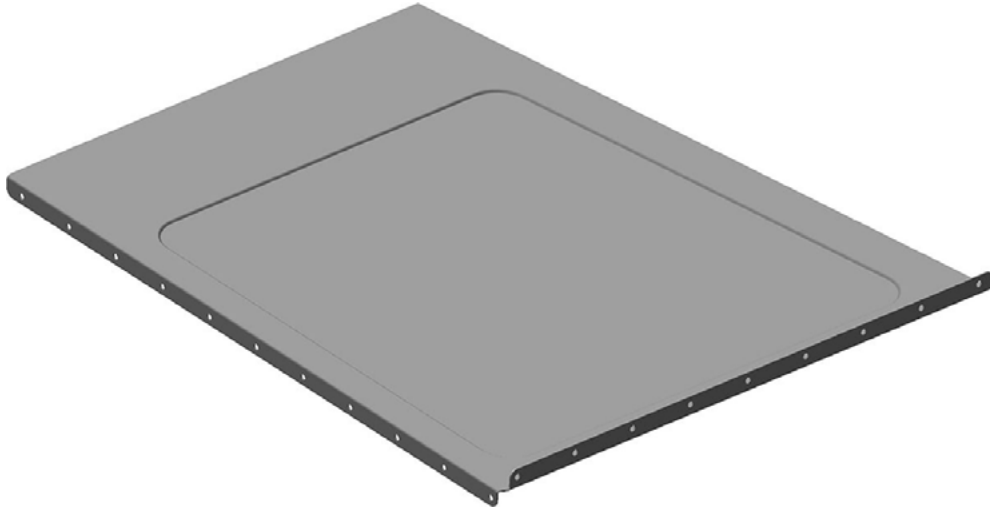

- 150-FrontFloor-002.jpg

The floor panel sits flush with the bottom of the seat pan brace and rests on top of the firewall and tunnel flanges to create a lap joint. The distance from the rocker to the recess bend is measured at the front and rear of the opening.



- 150-FrontFloor-003.jpg



- 150-FrontFloor-004.jpg  
The measurements are transferred to the floor panel indicating how short to trim the panel.



- 150-FrontFloor-005.jpg  
Similar measurements are taken from the front of the seat pan brace to the firewall recessed flange bend.



- 150-FrontFloor-006.jpg  
These measurements are also marked on the panel, then connected using a straightedge.



- 150-FrontFloor-007.jpg

Once the panel has been trimmed and verified to fit correctly, it is marked for drilling the plug weld holes. Marks are made two inches apart and one-quarter inch in from the edge.



- 150-FrontFloor-008.jpg

A 3/16" hole is drilled at each of the marks.



- 150-FrontFloor-009.jpg

The floor is then put into position so that it is flush on the bottom side with the seat pan and runs slightly uphill against the rocker. Plug welds are placed from the top for the firewall, tunnel, and seat pan seams and from underneath the floor for the rocker.



- 150-FrontFloor-010.jpg

With both sides of the front floor installed, the seams at the front and rear of the tunnel can be final welded.



## Mid Floor

- The section of floor between the seat pan and rear crossmember is made up of two individual pieces per side.
- 160-MidFloor-001.jpg  
The raised corner is the most notable feature of this panel and forms the raised exhaust channel. Three folded flanges are drilled for plug welds against flat portions of the chassis.

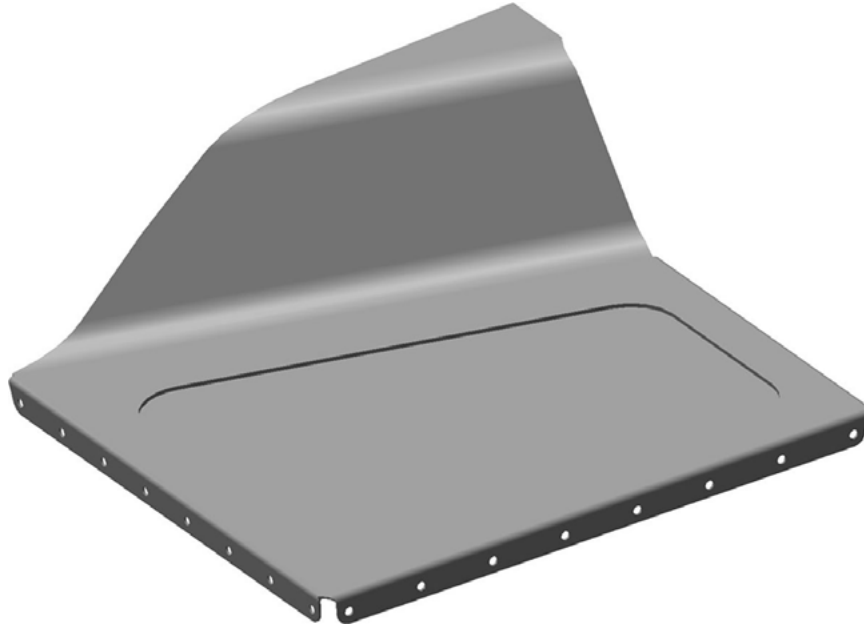

- 160-MidFloor-002.jpg  
Initially the floor is tacked from underneath so that it sits flush with the top of the seat pan and flat section of the subframe connector. The seam at the tunnel is tacked next, then the seam at the rear crossmember.



- 160-MidFloor-003.jpg

The outer panels have three folded flanges and a single flat edge, which is placed against the rocker. Rocked position may vary slightly, so the panel may need to be trimmed to fit.

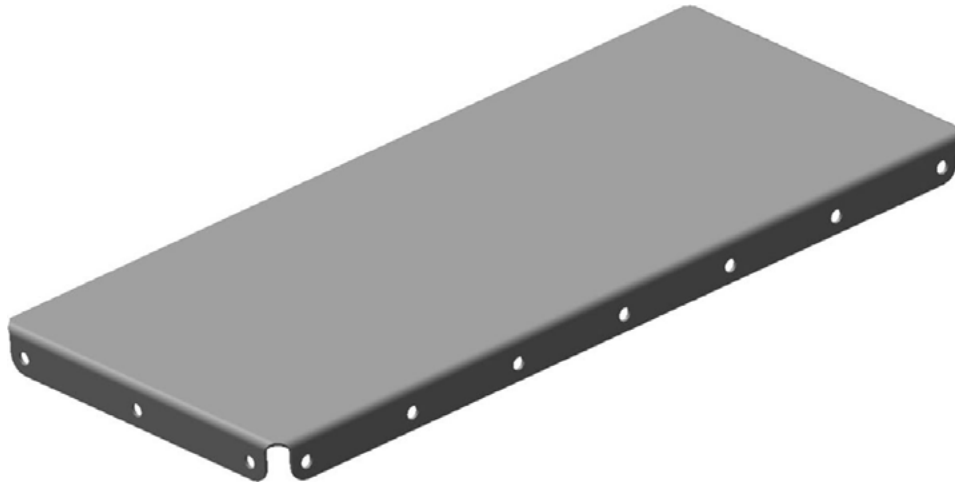

- 160-MidFloor-004.jpg

Flanged joints are structurally sound once plug welded. The tunnel and floor seams must be completely welded.



## Rear Panel

- Once the middle section of the floor is complete, the panel that sits above the rear suspension is installed.
- 170-RearPanel-001.jpg  
Viewed from the trunk side, panel features includes notches for the roll cage rear-strut supports, a cutout for optional shock remote reservoir mount, and bent flange to which the fuel cell is secured.

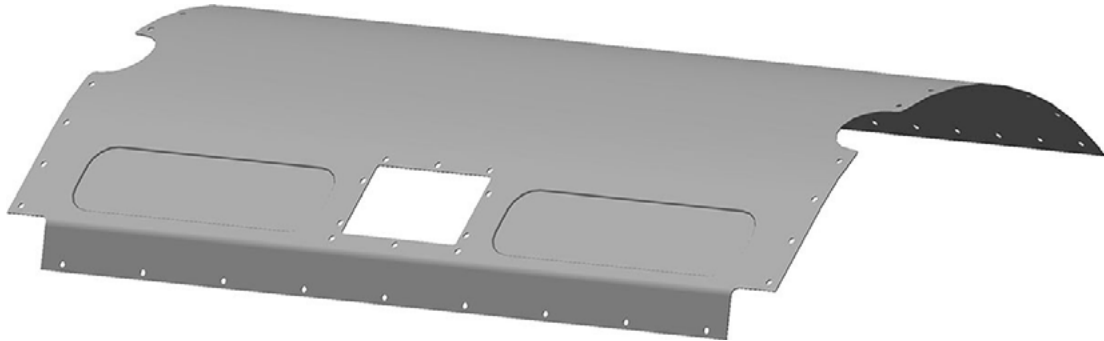

- 170-RearPanel-002.jpg

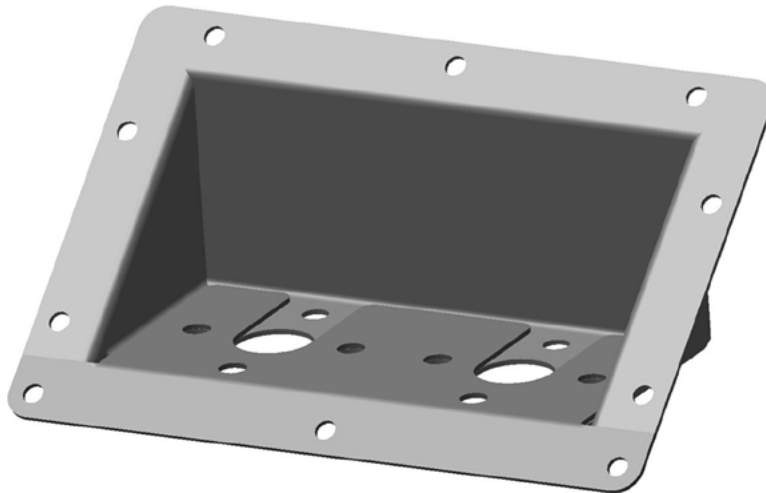

- 170-RearPanel-003.jpg  
The optional shock reservoir mount separates to fit around the shock hose, then bolts into place at the center of the panel. If standard double-adjustable shocks are chosen, a simple cap plate is used to cover the panel opening.

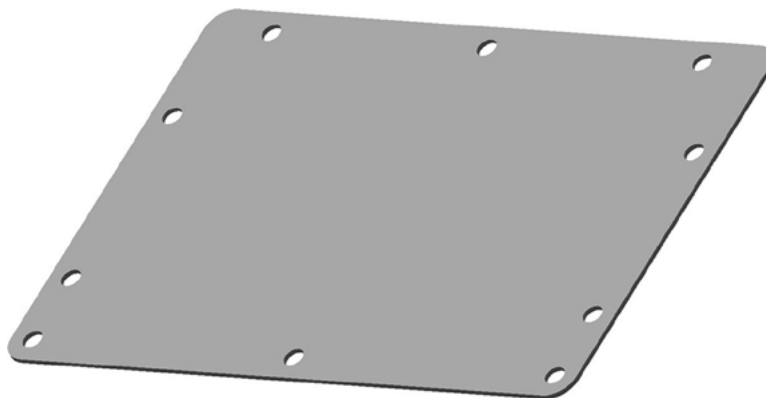

- 170-RearPanel-004.jpg

Position of the rear panel is determined by the fuel cell. The fuel cell is set in place, then the rear panel lined up with the matching mounting holes. After the panel is securely tacked, the fuel cell can be removed.



- 170-RearPanel-005.jpg

The forward edge of the panel attaches at the upper control arm crossmember, leaving the front edge of the crossmember open for attachment of the rear floor.



- 170-RearPanel-006.jpg

The welds at the crossmember must be completed before continuing with the next panel.



## Rear Floor

- 180-RearFloor-001.jpg

The center portion of the rear floor is made up of two pieces; the floor panel that extends from the rear crossmember to the upper control arm crossmember and rear tunnel section. All flanges that attach directly to the frame are predrilled.



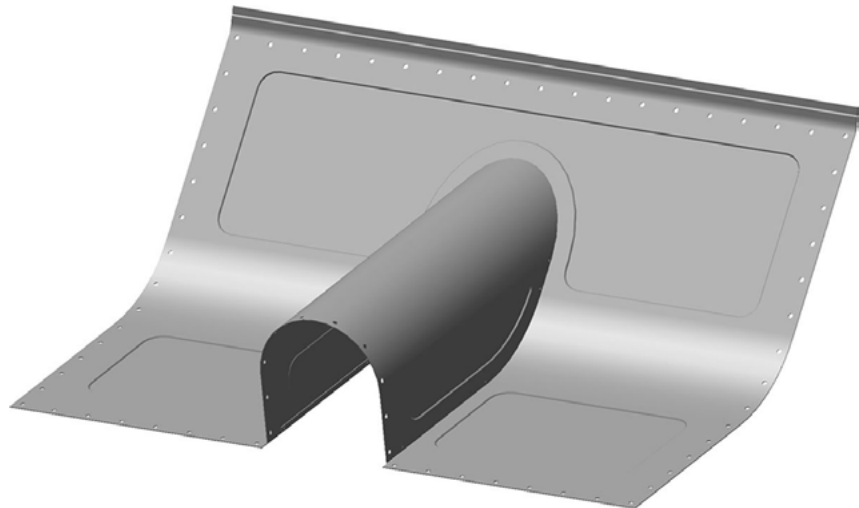
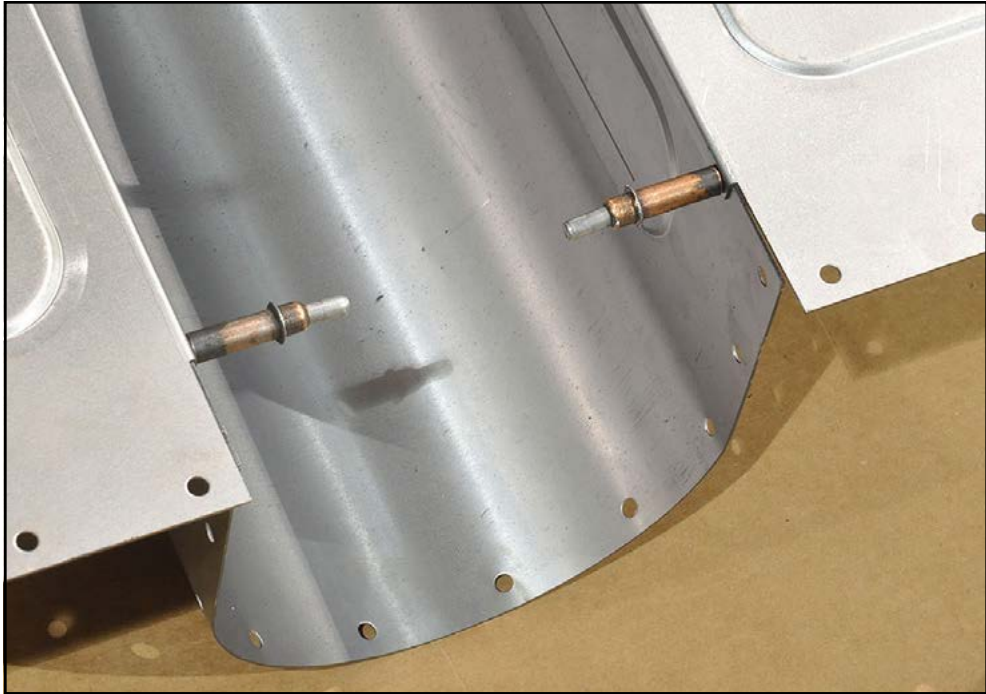

- 180-RearFloor-002.jpg

The floor panel is fit first and aligned 3/16" back from the front edge of the crossmember to avoid leaving a sharp corner. An angled lip along the top edge will join with the rear firewall.



- 180-RearFloor-003.jpg

Bent flanges on the floor panel help to position the rear tunnel and create a stronger joint that is much easier to weld. This seam must be completely welded.



- 180-RearFloor-004.jpg  
The outside pieces overlap the rear frame crossmember and provide a bent flange to help secure the front edge of the wheel tubs.

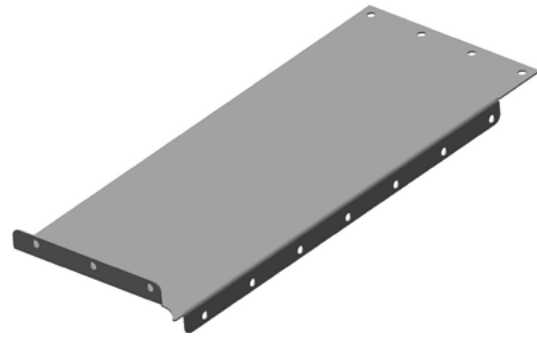

- 180-RearFloor-005.jpg  
This is viewed from the wheel side. The piece should only be lightly tack welded at this time in case we need to make any adjustments when fitting the tubs.



- 180-RearFloor-006.jpg  
The remaining components (wheel tubs, firewall) fit against the rear panel to close up the interior tin work.

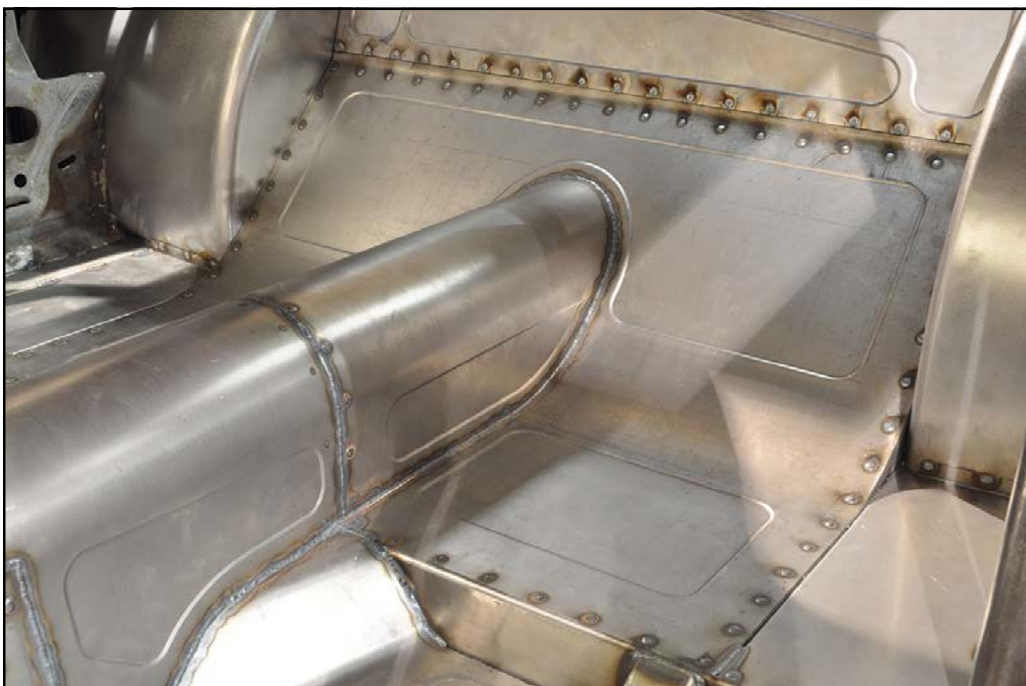

## Wheel Tubs

- 190-WheelTubs-001.jpg

Wheels are shipped as an easy to assembly two-piece unit. The tub wall exactly matches the frame rail bend with a cutout already in place for the anti-roll bar mounting boss. A radius is rolled along the outside edge to form a smooth transition at the tub corner.



- 190-WheelTubs-002.jpg

A cardboard mock-up is built as a cutting template for the actual wheel tub. The tub wall outline is traced onto cardboard then cut out. The tub skin is traced onto cardboard so that the bend will form across the cardboard grain.



- 190-WheelTubs-003.jpg  
If the interior quarter panel interferes with the cardboard tub skin, the sheet metal will have to be trimmed for clearance at this time.



- 190-WheelTubs-004.jpg  
Viewed from the trunk, the wheel tub seats against the rear frame rail and outrigger.



- 190-WheelTubs-005.jpg  
After removing the cardboard mock-up from the car, the outline is traced onto the sheet metal skin before trimming to the correct shape.



- 190-WheelTubs-006.jpg  
Staggered holes for the tub-to-frame rosette welds are marked and drilled along paths drawn  $\frac{1}{2}$ " and 3" from the edge. The large hole aligns with the threaded boss for the anti-roll bar.



- 190-WheelTubs-007.jpg  
The wheel tub is ready to verify final fit and tack into position.



- 190-WheelTubs-008.jpg  
Once in the correct position, the rosette welds are completed. The leading edge of the tub (image left) sits on top of the outboard floor panels and is welded at the pre-drilled holes.



- 190-WheelTubs-009.jpg

Depending upon the condition of the original sheet metal, the wheel housing/tub extension may remain. In this installation, the entire section was removed and replaced.



- 190-WheelTubs-010.jpg

The back of the tub is supported by the trunk floor panel and is seam sealed against the outer quarter panel skin to complete the wheel tub installation.



## Trunk Floor

- 200-TrunkFloor-001.jpg  
Rosette holes are pre-drilled and the notch for the roll cage rear strut cut into the outside trunk floor panels. The bent flange welds to the wheel tub.
- 200-TrunkFloor-002.jpg  
The panel should be very close to correctly fitting, but minor trimming along the quarter panel skin and around the rear strut weld may be necessary. To ensure the seams are perfectly aligned the fuel tank must be set in position.

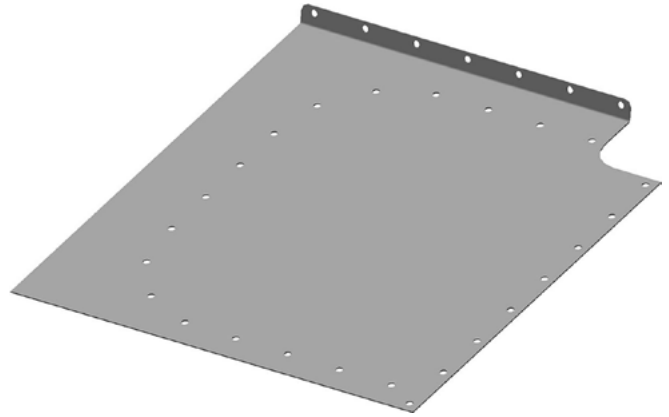

- 200-TrunkFloor-003.jpg  
The trunk is basically complete with the exception of the fuel tank, which is installed with removable fasteners.



## Rear Firewall

- 210-RearFirewall-001.jpg  
Closing up the interior is the rear firewall and side caps. Each panel is bent and pre-drilled.
- 210-RearFirewall-002.jpg  
The bottom flange sits over the large rear panel that was previously installed and is plug welded from the inside.

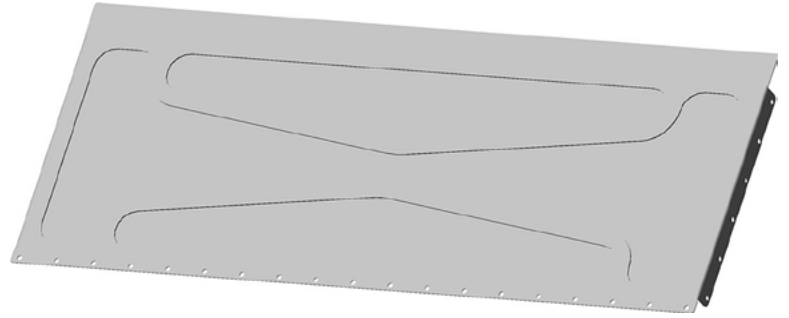

- 210-RearFirewall-003.jpg  
Bent flanges at the wheel tubs and the top edge along the rear deck are welded from inside the trunk.



- 210-RearFirewall-004.jpg
- 210-RearFirewall-005.jpg  
End caps feature a sharp bend to match the angles of the firewall and wheel tub. The small tab that extends downward follows the corner radius of the wheel tub.

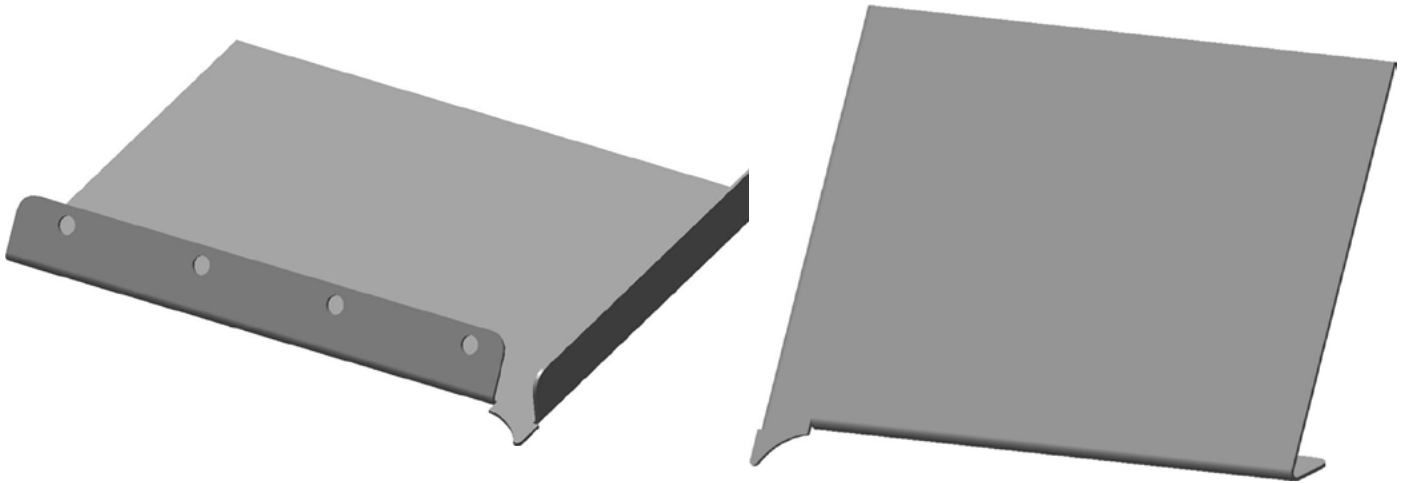

- 210-RearFirewall-006.jpg  
Welds are placed from the trunk side at the rear deck and through the pre-drilled holes on the firewall flange and bottom of the side cap.



## Fuel Tank

- 220-FuelTank-001.jpg



- 220-FuelTank-002.jpg



- 220-FuelTank-003.jpg



- 220-FuelTank-004.jpg



## Complete Interior

- 230-CompleteInterior-001.jpg



- 230-CompleteInterior-002.jpg



- 230-CompleteInterior-003.jpg



- 230-CompleteInterior-004.jpg



- 230-CompleteInterior-005.jpg



## Front Suspension

- 240-FrontSuspension-001.jpg



- 240-FrontSuspension-002.jpg

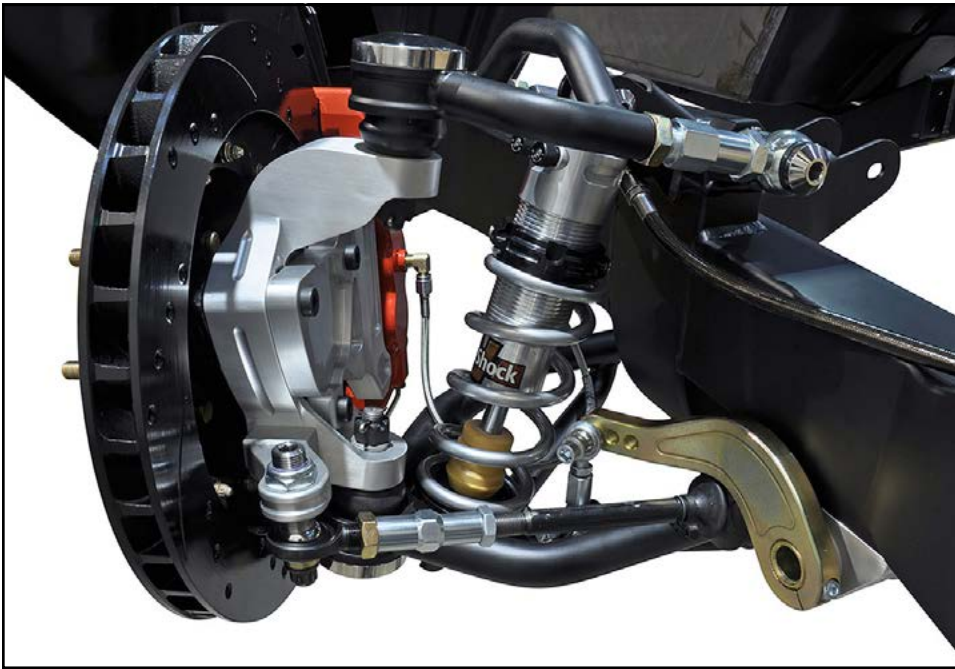

- 240-FrontSuspension-003.jpg



## Rear Suspension

- 250-RearSuspension-001.jpg



- 250-RearSuspension-002.jpg



- 250-RearSuspension-003.jpg

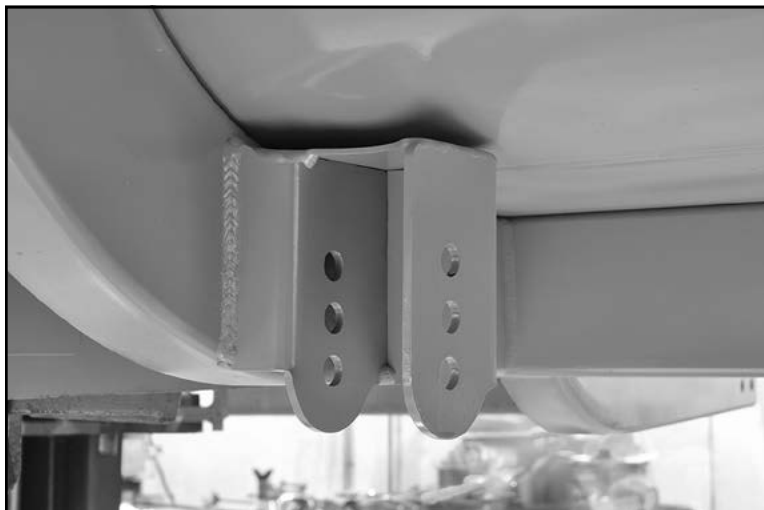

- 250-RearSuspension-004.jpg

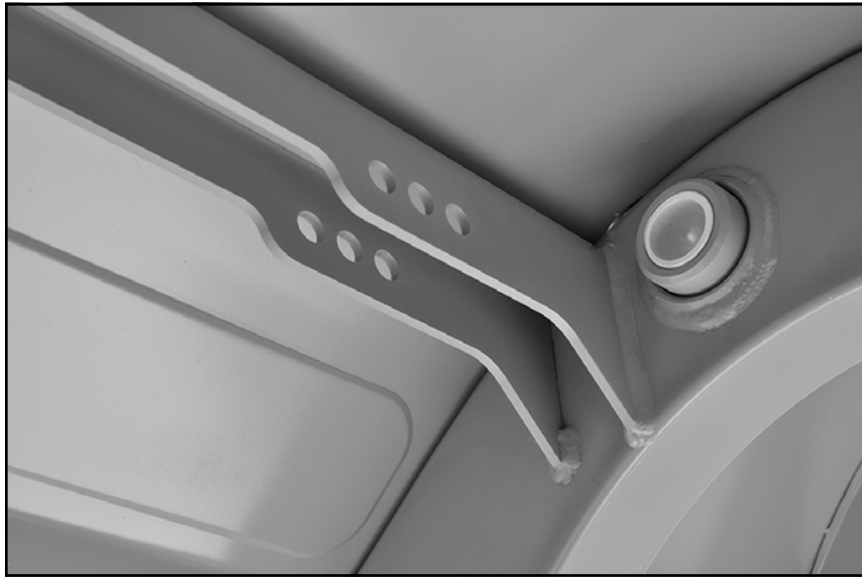

- 250-RearSuspension-005.jpg



- 250-RearSuspension-006.jpg



- 250-RearSuspension-007.jpg



- 250-RearSuspension-008.jpg



- 250-RearSuspension-009.jpg



- 250-RearSuspension-010.jpg



- 250-RearSuspension-011.jpg



- 250-RearSuspension-012.jpg



## Complete Exterior

- 260-CompleteExterior-001.jpg



- 260-CompleteExterior-002.jpg



- 260-CompleteExterior-003.jpg



- 260-CompleteExterior-004.jpg



- 260-CompleteExterior-005.jpg



- 260-CompleteExterior-006.jpg



- 260-CompleteExterior-007.jpg



## Scanning

- 999-Scanning-001.jpg  
Development of Chassisworks gStreet Pro-Touring Chassis begins with digitally scanning an original 1969 Camaro body. We position the body on jack stands at a comfortable working height for easier access to the majority of the vehicle body.



- 999-Scanning-002.jpg

- 999-Scanning-003.jpg

We chose to use a combination of portable coordinate measuring machines to capture both the exterior and interior surfaces. A large range of movement makes scanning the outside of the body much easier, which requires use of a laser tracker system. The tracking head sits atop the stationary base and automatically articulates to follow the handheld units.



- 999-Scanning-004.jpg

The wireless probe is followed by the tracking head to find its exact location and orientation in space.



- 999-Scanning-005.jpg  
Reference pucks, epoxied to the floor around the car and directly to the body in multiple locations, allow repositioning of the tracker base and body when needed.

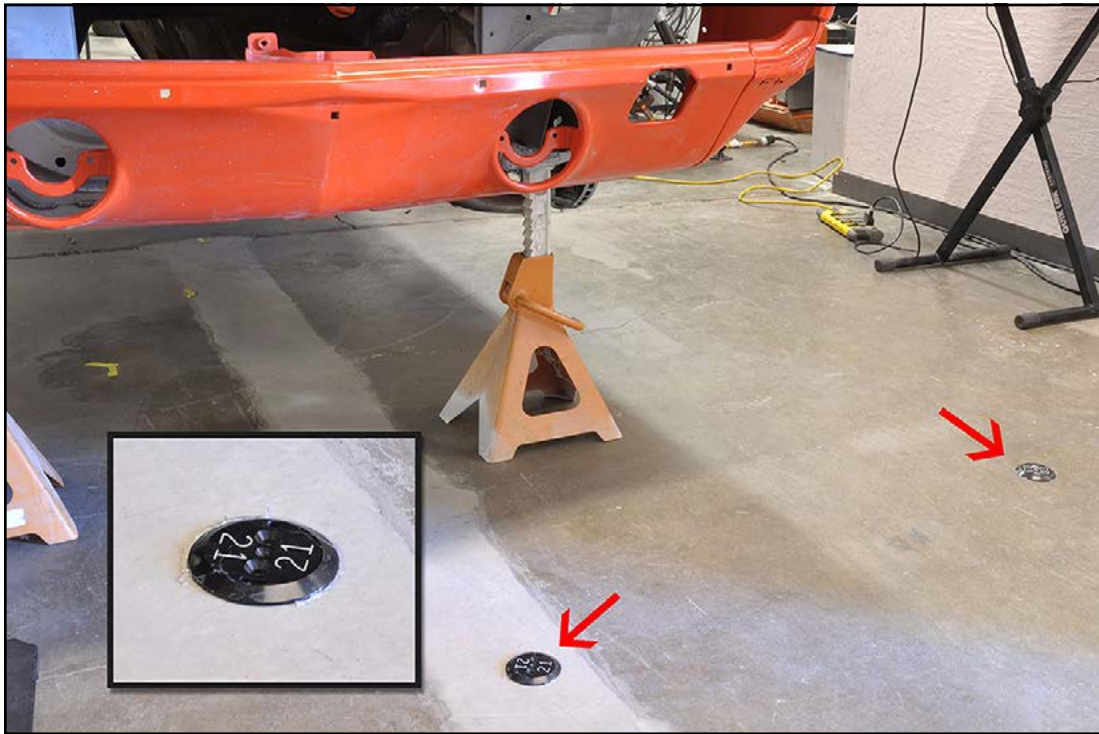

- 999-Scanning-006.jpg  
Together, the laser tracker and handheld wireless probe pinpoints the exact location of each reference puck. This step is done before and after moving the tracker base or vehicle body.



- 999-Scanning-007.jpg  
The scanning laser is what actually digitizes or records the dimensional information of the surface.



- 999-Scanning-008.jpg  
A wide beam cast onto the surface allows scanning of a larger area per pass, similar to spraying paint. A direct line of sight must be maintained between the tracker and scanner, so this method is used solely for the outside of the body.



- 999-Scanning-009.jpg

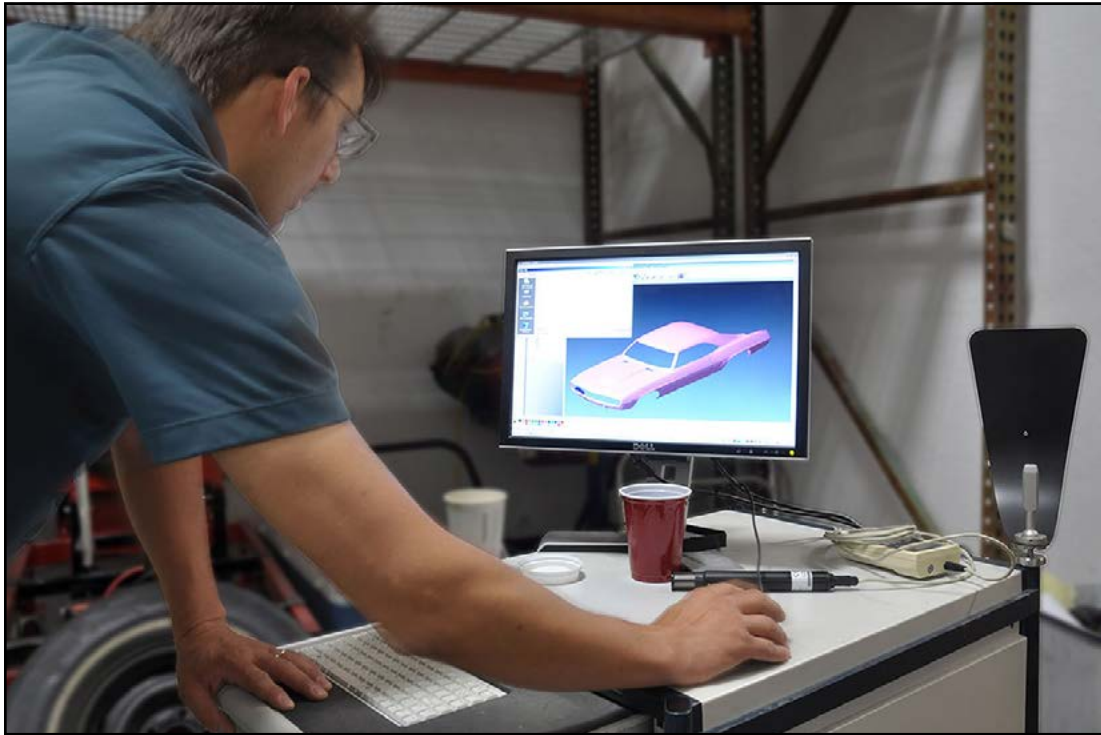

- 999-Scanning-009a.jpg  
Scanned information is displayed in real-time on the computer monitor and allows us to verify that any areas have not been missed.

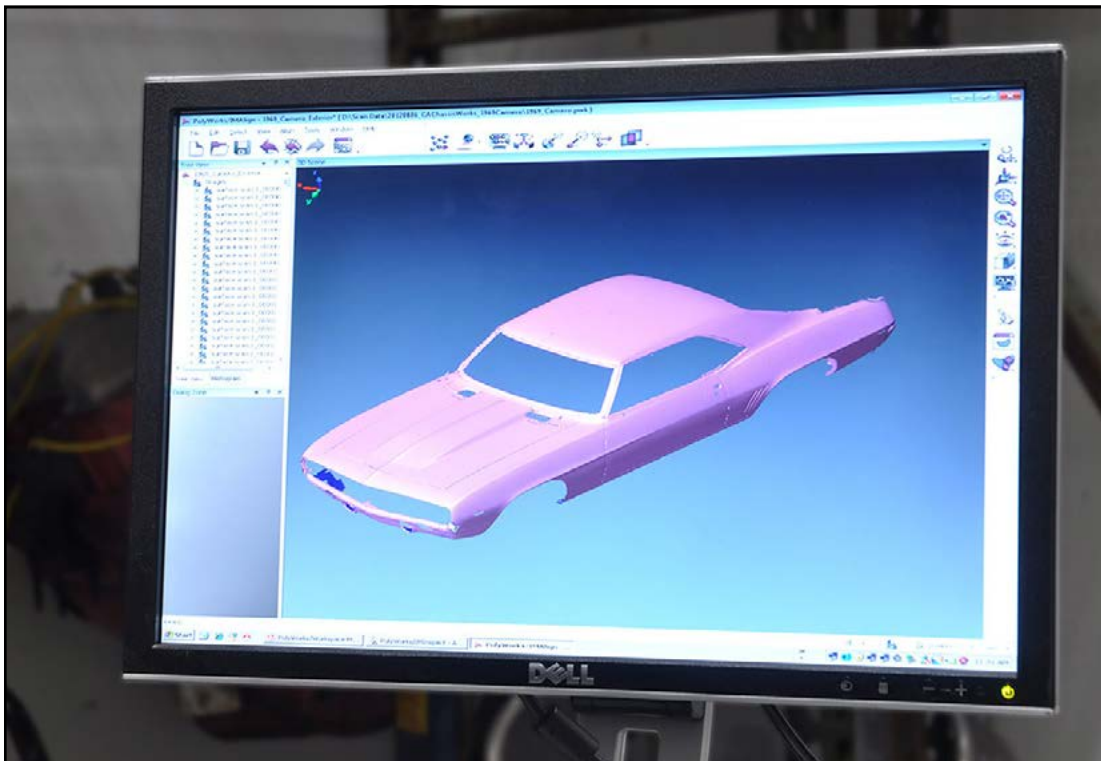

- 999-Scanning-010.jpg  
Scanning the interior requires a different piece of equipment due to the broken line of sight with the tracker. A portable segmented measurement arm can be positioned where needed and allows access to confined spaces.



- 999-Scanning-011.jpg  
All interior surfaces are scanned, including behind the dashboard. An exact-fit roll cage will be designed using this information.



- 999-Scanning-012.jpg  
Even though the entire floor will be replaced by the new chassis and tin work, this information is recorded for comparison to the new chassis and development of future products.



- 999-Scanning-013.jpg  
Here the beam can be clearly seen scanning the joint between the wheel tub and rear floor.



- 999-Scanning-014.jpg

Bolt-on parts such as the bumpers, fenders, and doors are also scanned removed the vehicle so they can be added or moved freely in the computer model.



- 999-Scanning-015.jpg

After scanning everything topside, the body is mounted on a rotisserie. The reference pucks are rescanned once the car is mounted and rotated before continuing with the exterior scan.



- 999-Scanning-016.jpg  
With the undercarriage scanning finished the data is compiled and development of a brand new chassis system begins.



- 999-Scanning-017.jpg  
Working within the three-dimensional scan of the OEM body our engineers created a full-length tubular chassis more suitable for the ultimate pro-touring performance car.

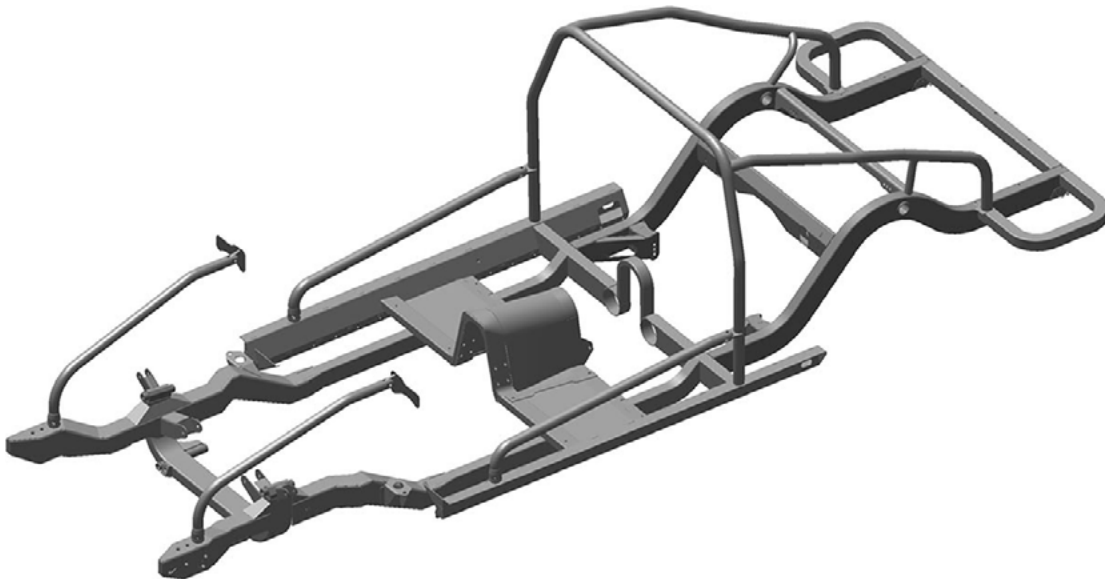

- 999-Scanning-018.jpg  
Initially developed for the first generation Camaro and Firebird, Chassisworks now has full chassis available for second generation Camaro/Firebird, and '67-68 Mustang platforms.

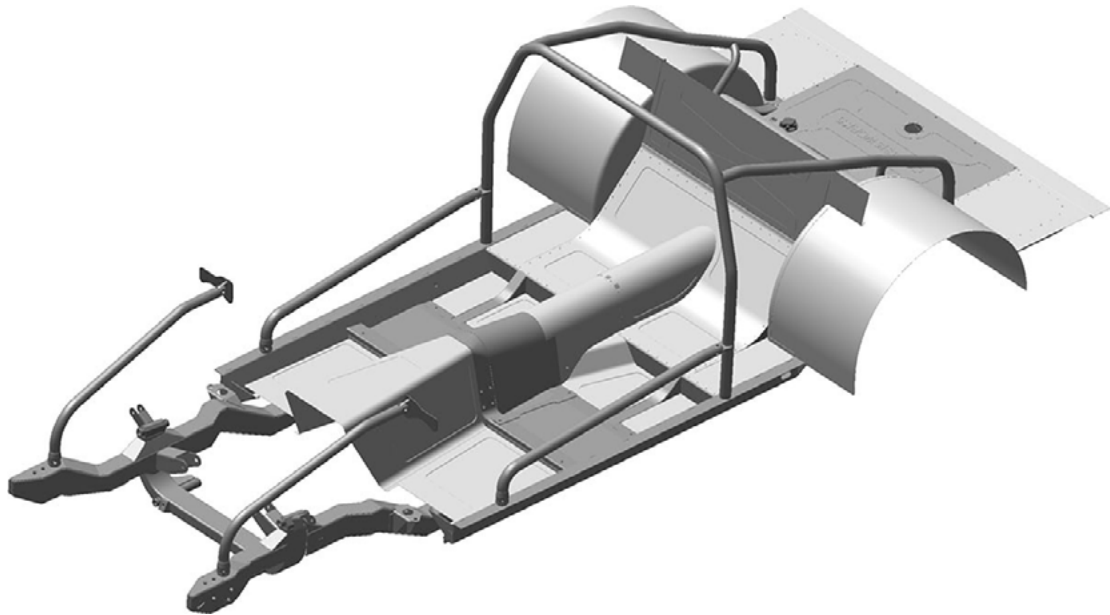

- 999-Scanning-019.jpg

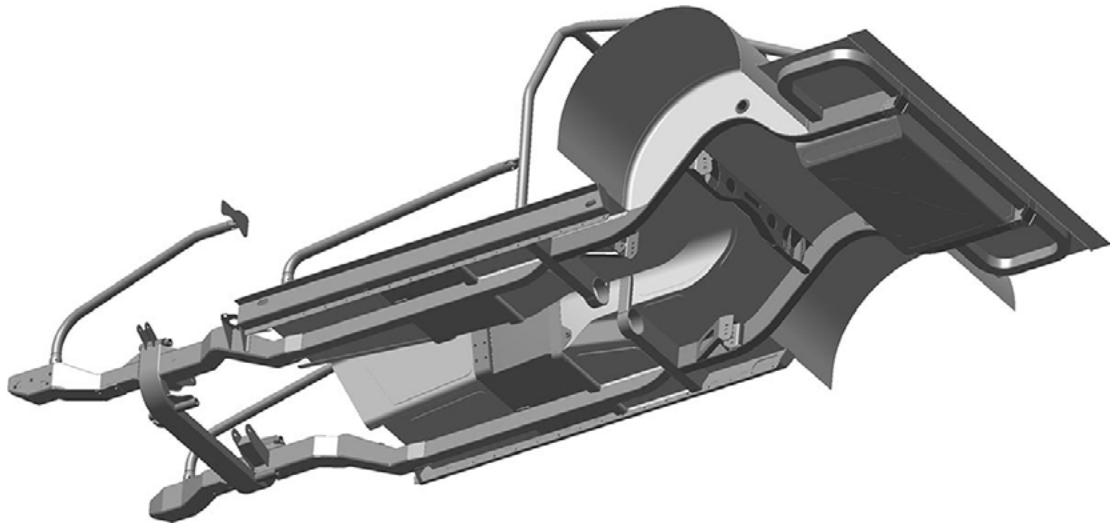

- 999-Scanning-020.jpg

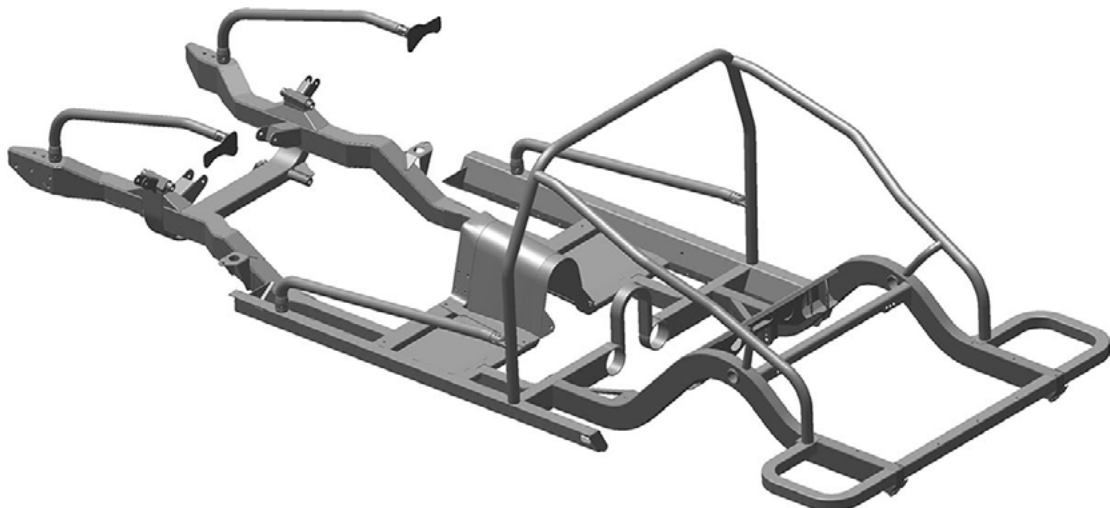

# Canted 4-Link Chassis

Sheet 1 of 5

THIS DRAWING CONTAINS PROPRIETARY INFORMATION OF CHRIS ALSTON'S CHASSISWORKS, INC. AND SHALL NOT BE REPRODUCED, TRANSFERRED TO OTHER DOCUMENTS, DISCLOSED TO OTHERS, USED FOR MANUFACTURING, OR FOR ANY OTHER PURPOSE, IN WHOLE OR IN PART WITHOUT PRIOR WRITTEN PERMISSION OF CHRIS ALSTON'S CHASSISWORKS, INC.

REVISIONS				
ZONE	REV	DESCRIPTION	DATE	APPROVED

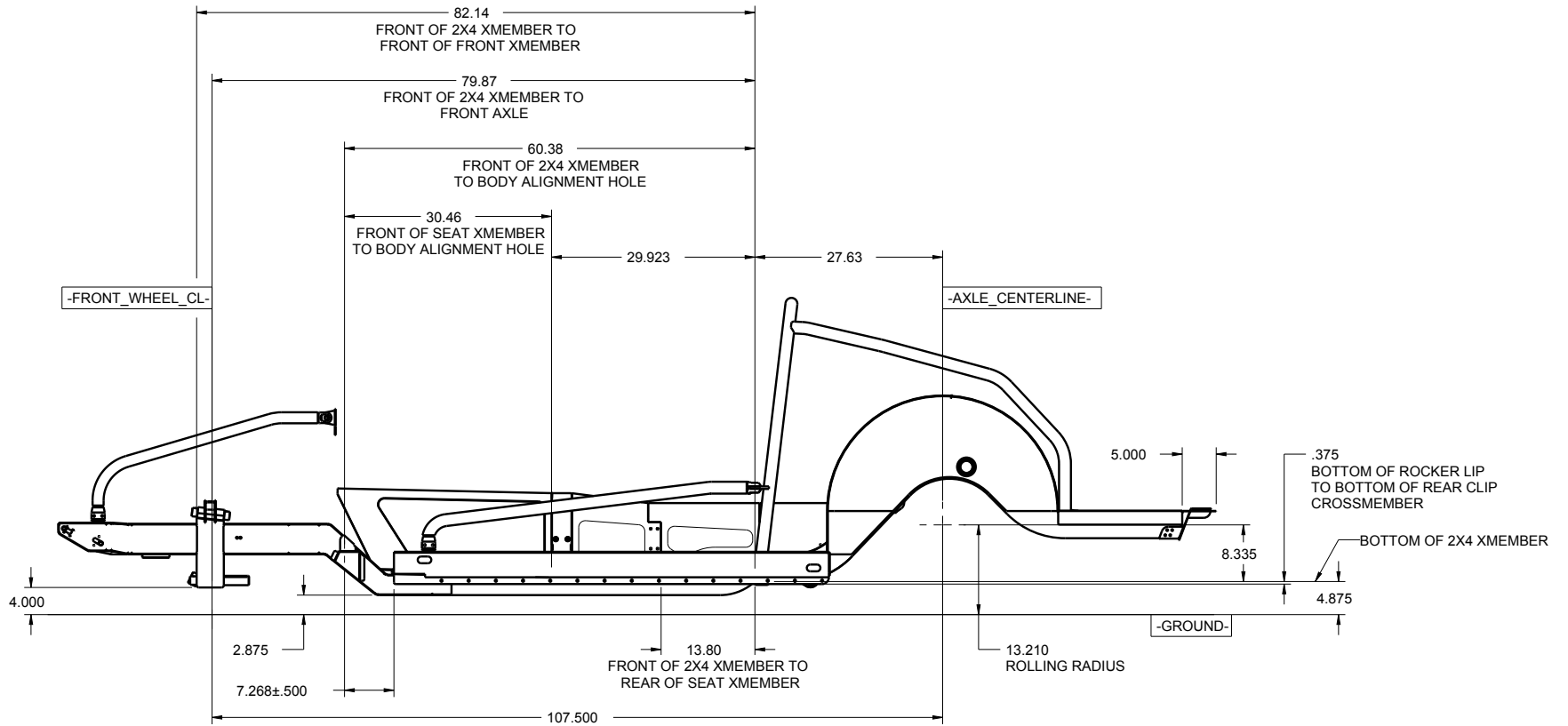

124

UNLESS OTHERWISE SPECIFIED	APPROVALS	DATE	DESCRIPTION		
DIMENSIONS ARE IN INCHES TOLERANCES FRACTIONS ANGLES DECIMAL ± 1/16 ± .5 ± 1 ± .05 ± .01 ± .005 ± .005 ± .0010	DRAWN BY: D. HOESCHEN	3/16/17	95 STREET, 70-81 CAMARO, FULL FRAME, CANTED 4-BAR, MARK-II FRONT CLIP		
	CHECKED BY: S. RIEGER	4/11/17			
	DWG RELEASE LEVEL: In Work			Chris Alston's CHASSISWORKS INC. 8661 YOUNGER CREEK DRIVE SACRAMENTO, CA 95828 (916) 388-0288 FAX 388-0295	
	FINISH NONE			SIZE B	PART NO. 7740-F20
MATERIAL ASSEMBLY			PART REV. 0		
SCALE: 1:16			DWG: 7951-7740F20 REV: 0.4		
			SHEET 1 OF 5		

# Canted 4-Link Chassis

THIS DRAWING CONTAINS PROPRIETARY INFORMATION OF CHRIS ALSTON'S CHASSISWORKS, INC. AND SHALL NOT BE REPRODUCED, TRANSFERRED TO OTHER DOCUMENTS, DISCLOSED TO OTHERS, USED FOR MANUFACTURING, OR FOR ANY OTHER PURPOSE, IN WHOLE OR IN PART WITHOUT PRIOR WRITTEN PERMISSION OF CHRIS ALSTON'S CHASSISWORKS, INC.

REVISIONS				
ZONE	REV	DESCRIPTION	DATE	APPROVED

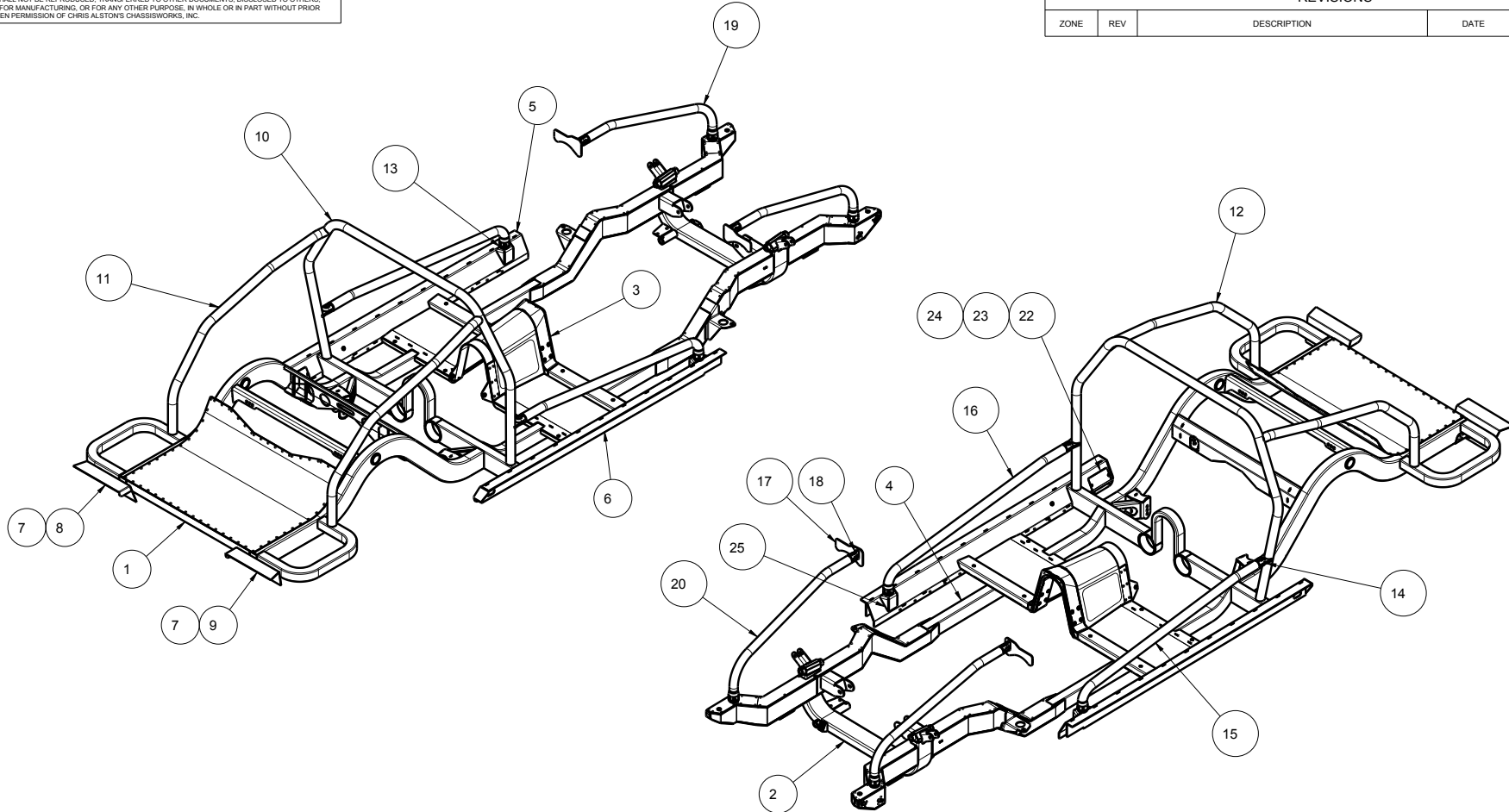

125

UNLESS OTHERWISE SPECIFIED	APPROVALS	DATE	DESCRIPTION		
DIMENSIONS ARE IN INCHES TOLERANCES FRACTIONS ANGLES DECIMAL ± 1/16 ± .5 ± 1 ± .05 ± .01 ± .005 ± .005 ± .0010	DRAWN BY: D. HOESCHEN	3/16/17	9500 STREET, 70-81 CAMARO, FULL FRAME, CANTED 4-BAR, MARK-II FRONT CLIP		
	CHECKED BY: S. RIEGER	4/11/17			
	DWG RELEASE LEVEL: In Work			Chris Alston's CHASSISWORKS INC. 8661 YOUNGER CREEK DRIVE SACRAMENTO, CA 95828 (916) 388-0288 FAX 388-0295	
	FINISH NONE			SIZE B	PART NO. 7740-F20
MATERIAL ASSEMBLY			PART REV. 0		
			SCALE: 1:20	DWG: 7951-7740F20 REV: 0.4	
			SHEET 2 OF 5		

# Canted 4-Link Chassis

THIS DRAWING CONTAINS PROPRIETARY INFORMATION OF CHRIS ALSTON'S CHASSISWORKS, INC. AND SHALL NOT BE REPRODUCED, TRANSFERRED TO OTHER DOCUMENTS, DISCLOSED TO OTHERS, USED FOR MANUFACTURING, OR FOR ANY OTHER PURPOSE, IN WHOLE OR IN PART WITHOUT PRIOR WRITTEN PERMISSION OF CHRIS ALSTON'S CHASSISWORKS, INC.

REVISIONS				
ZONE	REV	DESCRIPTION	DATE	APPROVED

126

ITEM	QTY	PART NO.	DESCRIPTION
1	1	7972-2233	4 x 2 REAR FRAME CLIP, G-STREET F20 CAMARO
2	1	5603-51	gSTREET FRONT CLIP, STD MTR MNT, 70-73 CAMARO/FIREBIRD
3	1	7972-2226	CROSSMEMBER WELDMENT, SEAT MOUNT, gSTREET, 70-81 CAMARO
4	2	7972-2152	SUBFRAME CONNECTOR, PRO/TOURING, F10
5	1	7972-2258	ROCKER ASSEMBLY, DRIVER, gSTREET CAMARO, F20
6	1	7972-2259	ROCKER ASSEMBLY, PASSENGER, gSTREET CAMARO, F20
7	2	7972-2378	HANGER MOUNT, REAR VALANCE, CANTED 4-BAR, F20
8	1	7972-2376	FILLER PANEL, REAR VALANCE, DRIVER, 70-?? CAMARO
9	1	7972-2377	FILLER PANEL, REAR VALANCE, PASSENGER, 70-?? CAMARO
10	1	4871-01-1	MAIN HOOP, PRO/TOURING F2 CAMARO
11	1	4871-12-1	REAR STRUT, DRIVER PRO/TOURING F2 CAMARO
12	1	4871-13-1	REAR STRUT, PASSENGER, PRO/TOURING F2 CAMARO
13	4	1146	JOINT PLUG $\varnothing$ 1.95 OD FLAT
14	2	2840	BRACKET, BACKBRACE, 1 3/4 TUBE, 3/8 x 1/2 HOLE x 2.13 CENTER
15	1	7051-F20-1	SIDE BAR, REMOVABLE, DRIVER, F20, PRO/TOURING CAMARO
16	1	7051-F20-2	SIDE BAR, REMOVABLE, PSGR, F20, PRO/TOURING CAMARO
17	2	7972-2120	BRACKET, FORWARD STRUT, WELD-ON, F10
18	2	2839	BRACKET, FIREWALL TAB, 3/8 x 1/2 HOLE x 1.25 EDGE TO HOLE
19	1	7051-F10-4	FORWARD STRUT, DRIVER, PRO/TOURING CAMARO
20	1	7051-F10-5	FORWARD STRUT, PSGR, PRO/TOURING CAMARO
21	1	7972-2371	TRUNK FLOOR, IRS, F20
22	2	7972-2170	COVER, WIREWAY, REAR ROCKER, NEW, CANTED 4-BAR, F10
23	4	3108-019L-C	LOCK WASHER, HELICAL SPRING #10, STEEL, ZINC
24	4	3104-019F0.38S	BUTTON HEAD SOCKET CAP SCREW 10-32 x 3/8, STAINLESS STEEL
25	2	7972-2389	PLATFORM, ROCKER PANEL, A-PILLAR, F20

ROLL BAR

UNLESS OTHERWISE SPECIFIED		APPROVALS	DATE	DESCRIPTION <b>gSTREET, 70-81 CAMARO, FULL FRAME, CANTED 4-BAR, MARK-II FRONT CLIP</b>  Chris Alston's CHASSISWORKS INC. 8661 YOUNGER CREEK DRIVE SACRAMENTO, CA 95828 (916) 388-0288 FAX 388-0295
DIMENSIONS ARE IN INCHES TOLERANCES FRACTIONS ANGLES DECIMAL ± 1/16 ± .01 ± .1 ± .05 ± .01 ± .005 ± .005 ± .0010		DRAWN BY: D.HOESCHEN	3/16/17	
		CHECKED BY: S. RIEGER	4/11/17	
		DWG RELEASE LEVEL: In Work		
FINISH <b>NONE</b>		SIZE <b>B</b>	PART NO. <b>7740-F20</b>	PART REV. <b>0</b>
MATERIAL <b>ASSEMBLY</b>		SCALE: 1:16		DWG: 7951-7740F20 REV: 0.4
				SHEET 3 OF 5

# Canted 4-Link Chassis

THIS DRAWING CONTAINS PROPRIETARY INFORMATION OF CHRIS ALSTON'S CHASSISWORKS, INC. AND SHALL NOT BE REPRODUCED, TRANSFERRED TO OTHER DOCUMENTS, DISCLOSED TO OTHERS, USED FOR MANUFACTURING, OR FOR ANY OTHER PURPOSE, IN WHOLE OR IN PART WITHOUT PRIOR WRITTEN PERMISSION OF CHRIS ALSTON'S CHASSISWORKS, INC.

REVISIONS				
ZONE	REV	DESCRIPTION	DATE	APPROVED

127

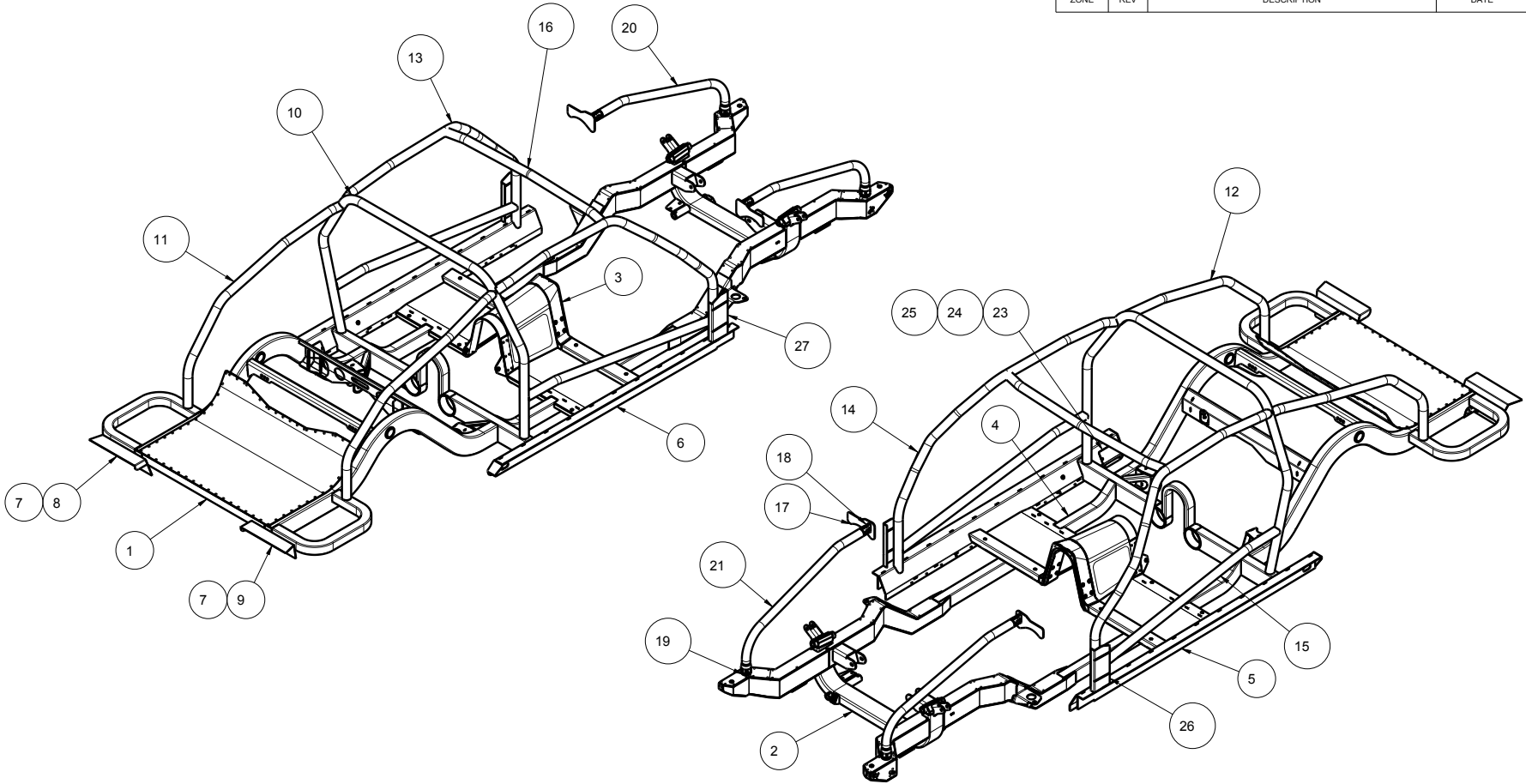

UNLESS OTHERWISE SPECIFIED	APPROVALS	DATE	DESCRIPTION		
DIMENSIONS ARE IN INCHES TOLERANCES FRACTIONS ANGLES DECIMAL ± 1/16 ± ° ± .1 ± .05 ± .01 ± .005 ± .005 ± .0010	DRAWN BY: D. HOESCHEN	3/16/17	9511 STREET, 70-81 CAMARO, FULL FRAME, CANTED 4-BAR, MARK-II FRONT CLIP		
	CHECKED BY: S. RIEGER	4/11/17			
	DWG RELEASE LEVEL: In Work			Chris Alston's CHASSISWORKS INC. 8661 YOUNGER CREEK DRIVE SACRAMENTO, CA 95828 (916) 388-0288 FAX 388-0295	
	FINISH NONE			SIZE B	PART NO. 7740-F20
MATERIAL ASSEMBLY			PART REV. 0		
SCALE: 1:20		DWG: 7951-7740F20 REV: 0.4		SHEET 4 OF 5	

# Canted 4-Link Chassis

THIS DRAWING CONTAINS PROPRIETARY INFORMATION OF CHRIS ALSTON'S CHASSISWORKS, INC. AND SHALL NOT BE REPRODUCED, TRANSFERRED TO OTHER DOCUMENTS, DISCLOSED TO OTHERS, USED FOR MANUFACTURING, OR FOR ANY OTHER PURPOSE, IN WHOLE OR IN PART WITHOUT PRIOR WRITTEN PERMISSION OF CHRIS ALSTON'S CHASSISWORKS, INC.

REVISIONS				
ZONE	REV	DESCRIPTION	DATE	APPROVED

ITEM	QTY	PART NO.	DESCRIPTION
1	1	7972-2233	4 x 2 REAR FRAME CLIP, G-STREET F20 CAMARO
2	1	5603-51	gSTREET FRONT CLIP, STD MTR MNT, 70-73 CAMARO/FIREBIRD
3	1	7972-2226	CROSSMEMBER WELDMENT, SEAT MOUNT, gSTREET, 70-81 CAMARO
4	2	7972-2152	SUBFRAME CONNECTOR, PRO/TOURING, F10
5	1	7972-2258	ROCKER ASSEMBLY, DRIVER, gSTREET CAMARO, F20
6	1	7972-2259	ROCKER ASSEMBLY, PASSENGER, gSTREET CAMARO, F20
7	2	7972-2378	HANGER MOUNT, REAR VALANCE, CANTED 4-BAR, F20
8	1	7972-2376	FILLER PANEL, REAR VALANCE, DRIVER, 70-?? CAMARO
9	1	7972-2377	FILLER PANEL, REAR VALANCE, PASSENGER, 70-?? CAMARO
10	1	4871-01-1	MAIN HOOP, PRO/TOURING F2 CAMARO
11	1	4871-12-1	REAR STRUT, DRIVER PRO/TOURING F2 CAMARO
12	1	4871-13-1	REAR STRUT, PASSENGER, PRO/TOURING F2 CAMARO
13	1	4871-10-1	CAGE SIDE, THRU DASH, DRV, PRO/TOURING F2 CAMARO
14	1	4871-11-1	CAGE SIDE, THRU DASH, PSGR, PRO/TOURING F2 CAMARO
15	2	4871-17-1	SIDE BAR, ROLL CAGE, F20
16	1	4871-04-1	WINDSHIELD BRACE, PRO/TOURING F2 CAMARO
17	2	7972-2120	BRACKET, FORWARD STRUT, WELD-ON, F10
18	2	2839	BRACKET, FIREWALL TAB, 3/8 x 1/2 HOLE x 1.25 EDGE TO HOLE
19	2	1146	JOINT PLUG $\varnothing$ 1.95 OD FLAT
20	1	7051-F10-4	FORWARD STRUT, DRIVER, PRO/TOURING CAMARO
21	1	7051-F10-5	FORWARD STRUT, PSGR, PRO/TOURING CAMARO
22	1	7972-2371	TRUNK FLOOR, IRS, F20
23	2	7972-2170	COVER, WIREWAY, REAR ROCKER, NEW, CANTED 4-BAR, F10
24	4	3108-019L-C	LOCK WASHER, HELICAL SPRING #10, STEEL, ZINC
25	4	3104-019F0.38S	BUTTON HEAD SOCKET CAP SCREW 10-32 x 3/8, STAINLESS STEEL
26	1	7972-2265	CAGE SIDE NOTCH, DRIVER, 70-81 CAMARO gSTREET
27	1	7972-2266	CAGE SIDE NOTCH, PSGR, 70-81 CAMARO gSTREET

128

ROLL CAGE

UNLESS OTHERWISE SPECIFIED		APPROVALS	DATE	DESCRIPTION <b>gSTREET, 70-81 CAMARO, FULL FRAME, CANTED 4-BAR, MARK-II FRONT CLIP</b>
DIMENSIONS ARE IN INCHES TOLERANCES FRACTIONS ANGLES DECIMAL $\pm$ 1/16 $\pm$ $\frac{\circ}{16}$ $\pm$ .1 $\pm$ .05 $\pm$ .01 $\pm$ .005 $\pm$ .005 $\pm$ .0010		DRAWN BY: D.HOESCHEN	3/16/17	
		CHECKED BY: S. RIEGER	4/11/17	Chris Alston's CHASSISWORKS INC. 8661 YOUNGER CREEK DRIVE SACRAMENTO, CA 95828 (916) 388-0288 FAX 388-0295
		DWG RELEASE LEVEL: In Work		
FINISH <b>NONE</b>		SIZE <b>B</b>	PART NO. <b>7740-F20</b>	PART REV. <b>0</b>
MATERIAL <b>ASSEMBLY</b>		SCALE: 1:16		DWG: 7951-7740F20 REV: 0.4
				SHEET 5 OF 5

# Canted 4-Link Chassis - Rear Floor

129

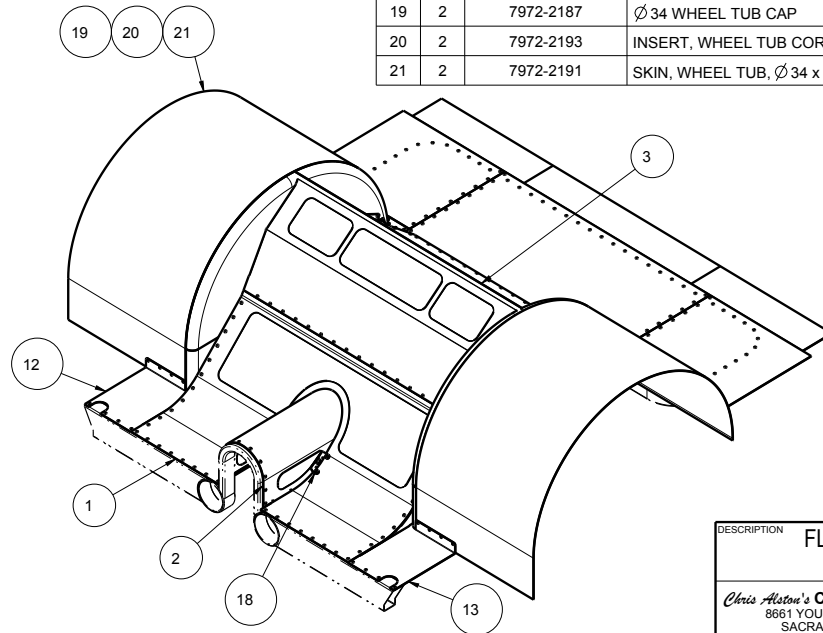
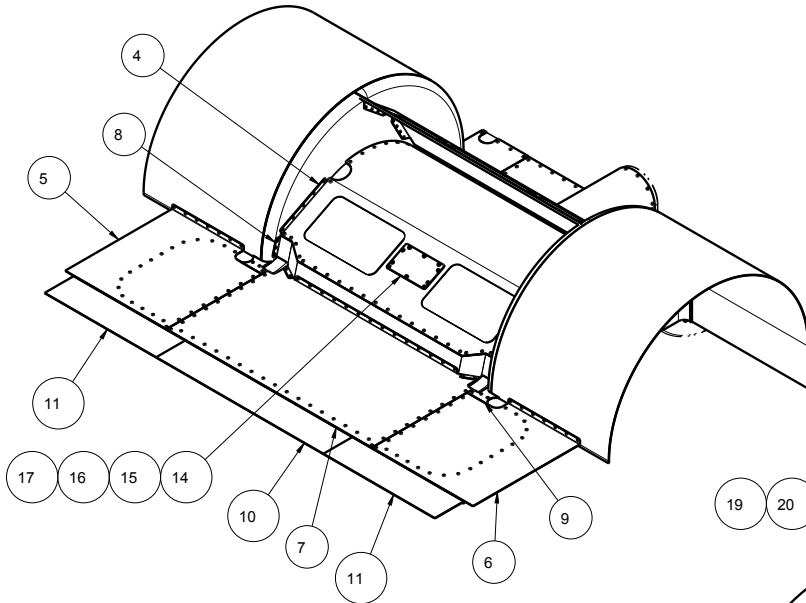

ITEM	QTY	PART NO.	DESCRIPTION
1	1	7972-2381	REAR FLOOR, AXLE FRONT, CANTED 4 BAR, F20
2	1	7972-2382	REAR TUNNEL TERMINATION, CANTED 4 BAR, F20
3	1	7972-2383	BULKHEAD, REAR FIREWALL, CANTED 4 BAR, F20
4	1	7972-2561	REAR FLOOR, OVER AXLE, CANTED 4-BAR, FLUSH FILLER, F20
5	1	7972-2385	REAR TRUNK FLOOR, DRIVER, CANTED 4-BAR, F20
6	1	7972-2386	REAR TRUNK FLOOR, PASSENGER, CANTED 4-BAR, F20
7	1	7972-2562	TRUNK FLOOR, CENTER, CANTED 4-BAR, FLUSH FILLER, F20
8	1	7972-2566	REAR PANEL, TRUNK, CANTED 4 BAR, FLUSH FILLER, F20
9	2	7972-2388	FILLER, TRUNK, CANTED 4-BAR, F20
10	1	7972-2361	REAR FLOOR FILLER, TRUNK, CENTER, IRS, F20
11	2	7972-2362	REAR FLOOR FILLER, TRUNK, OUTBOARD, IRS, F20
12	1	7972-2366	REAR FLOOR FILLER, FRONT AXLE, OUTBOARD PSGR, IRS, F20
13	1	7972-2365	REAR FLOOR FILLER, FRONT AXLE, OUTBOARD DRV, IRS, F20
14	1	7972-2550	COVER, RESERVOIR POCKET, CANTED 4-BAR, 27 DEGREE
15	10	3104-019F0.50S	BUTTON HEAD SOCKET CAP SCREW 10-32 x 1/2, STAINLESS STEEL
16	10	3157-019S-S	WASHER, #10 SAE, STAINLESS, 7/32 ID x .7/16 OD x 3/64 THICK
17	10	3101-019-32S	LOCKNUT 10-32, GRADE 5, STAINLESS STEEL
18	2	7972-2380	ALIGNMENT TOOL, FLOOR TO TUNNEL, IRS
19	2	7972-2187	Ø 34 WHEEL TUB CAP
20	2	7972-2193	INSERT, WHEEL TUB CORNER
21	2	7972-2191	SKIN, WHEEL TUB, Ø 34 x 60 LONG, 3.30 STRAIGHT, 20 WIDE

DESCRIPTION		FLOOR KIT, REAR, CANTED 4 BAR, gSTREET, 70-81 CAMARO	
Chris Aston's CHASSISWORKS INC. 8661 YOUNGER CREEK DRIVE SACRAMENTO, CA 95828 (916) 388-0289 FAX 388-0295		PART NO.	7740-F20-R
3/12/18	DWG: 7951-7740F20R		

# Coil-Over IRS Chassis

THIS DRAWING CONTAINS PROPRIETARY INFORMATION OF CHRIS ALSTON'S CHASSISWORKS, INC. AND SHALL NOT BE REPRODUCED, TRANSFERRED TO OTHER DOCUMENTS, DISCLOSED TO OTHERS, USED FOR MANUFACTURING, OR FOR ANY OTHER PURPOSE, IN WHOLE OR IN PART WITHOUT PRIOR WRITTEN PERMISSION OF CHRIS ALSTON'S CHASSISWORKS, INC.

REVISIONS				
ZONE	REV	DESCRIPTION	DATE	APPROVED

130

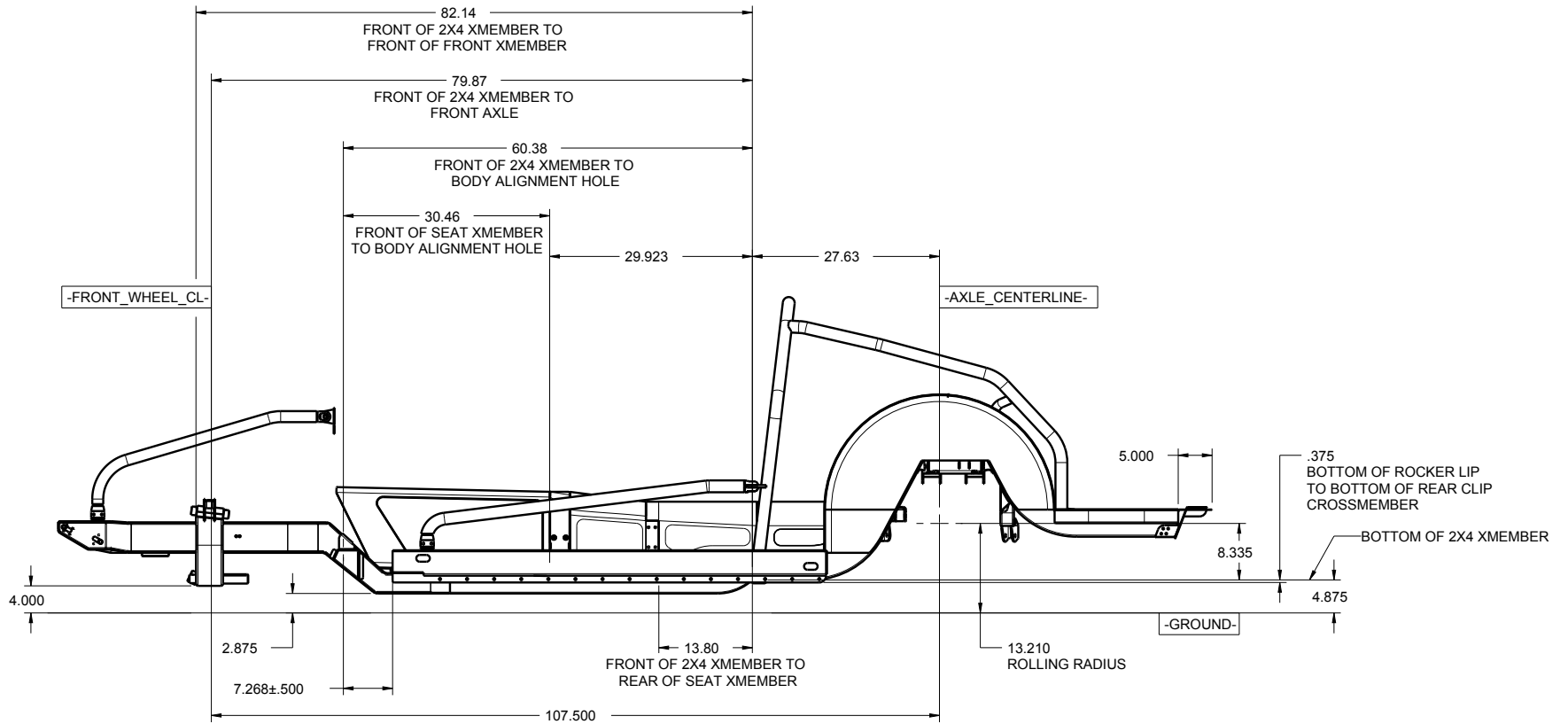

UNLESS OTHERWISE SPECIFIED		APPROVALS	DATE	DESCRIPTION
DIMENSIONS ARE IN INCHES TOLERANCES FRACTIONS ANGLES DECIMAL ± 1/16 ± ° ± .1 ± .05 ± .01 ± .005 ± .005 ± .0010		DRAWN BY: D.HOESCHEN	2/19/18	81ST STREET, 70-81 CAMARO, FULL FRAME, COILOVER IRS, MARK-II FRONT CLIP
FINISH NONE		CHECKED BY: S. RIEGER	2/19/18	
MATERIAL ASSEMBLY		DWG RELEASE LEVEL: In Work		Chris Alston's CHASSISWORKS INC. 8661 YOUNGER CREEK DRIVE SACRAMENTO, CA 95828 (916) 388-0288 FAX 388-0295
SIZE B	PART NO. 7742-F20	SCALE: 1:16		PART REV. 0
DWG: 7951-7742F20 REV: 0.1			SHEET 1 OF 5	

# Coil-Over IRS Chassis

THIS DRAWING CONTAINS PROPRIETARY INFORMATION OF CHRIS ALSTON'S CHASSISWORKS, INC. AND SHALL NOT BE REPRODUCED, TRANSFERRED TO OTHER DOCUMENTS, DISCLOSED TO OTHERS, USED FOR MANUFACTURING, OR FOR ANY OTHER PURPOSE, IN WHOLE OR IN PART WITHOUT PRIOR WRITTEN PERMISSION OF CHRIS ALSTON'S CHASSISWORKS, INC.

REVISIONS				
ZONE	REV	DESCRIPTION	DATE	APPROVED

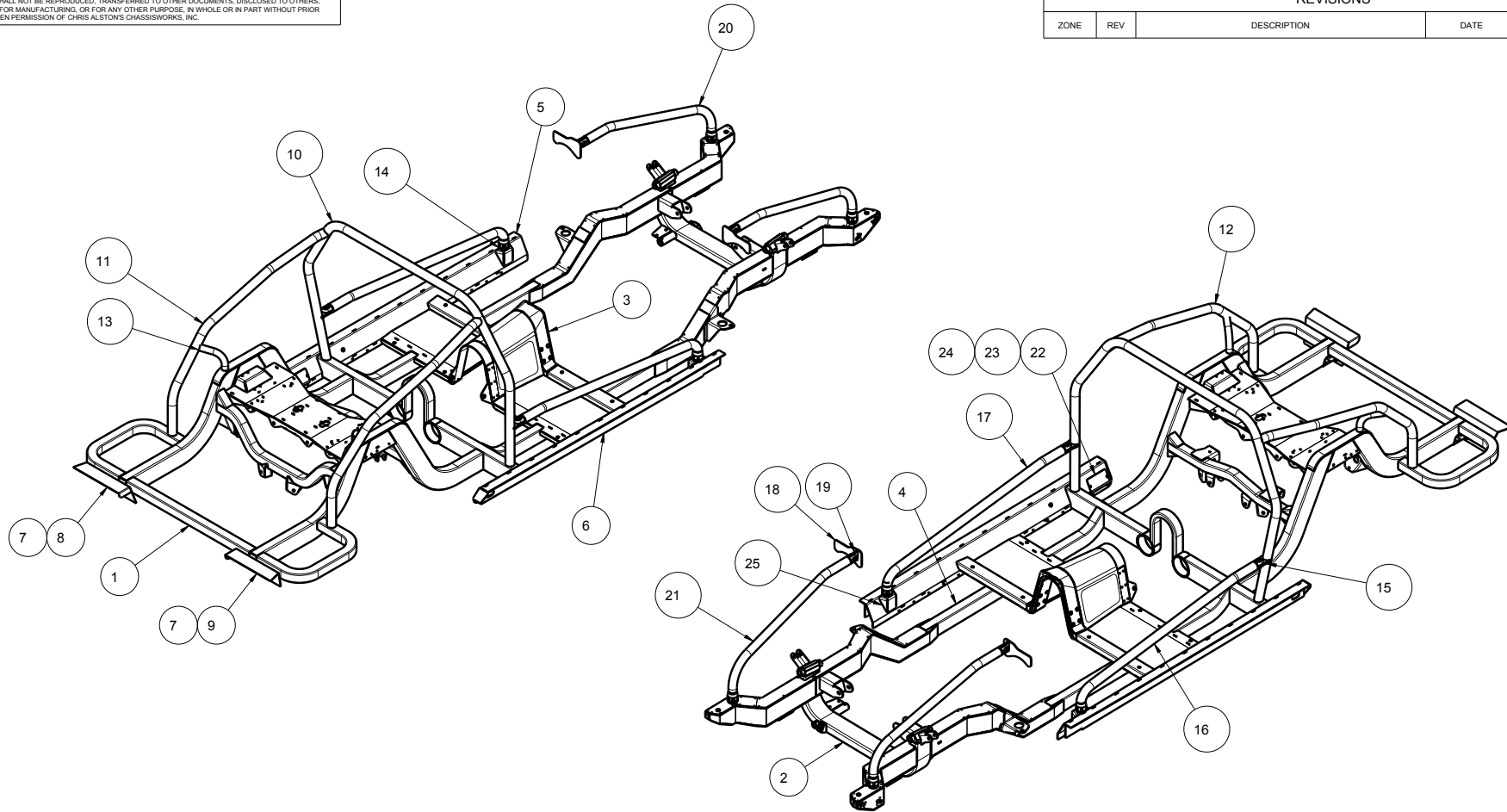

131

UNLESS OTHERWISE SPECIFIED	APPROVALS	DATE	DESCRIPTION		
DIMENSIONS ARE IN INCHES TOLERANCES FRACTIONS ANGLES DECIMAL ± 1/16 ± ° ± .1 ± .05 ± .01 ± .005 ± .005 ± .0010	DRAWN BY: D. HOESCHEN	2/19/18	9500 STREET, 70-81 CAMARO, FULL FRAME, COILOVER IRS, MARK-II FRONT CLIP		
	CHECKED BY: S. RIEGER	2/19/18			
	FINISH	DWG RELEASE LEVEL: In Work		Chris Alston's CHASSISWORKS INC. 8661 YOUNGER CREEK DRIVE SACRAMENTO, CA 95828 (916) 388-0288 FAX 388-0295	
	NONE	SIZE	PART NO.	7742-F20	PART REV.
MATERIAL	B			0	
ASSEMBLY	SCALE: 1:20	DWG: 7951-7742F20	REV: 0.1	SHEET 2 OF 5	

# Coil-Over IRS Chassis

THIS DRAWING CONTAINS PROPRIETARY INFORMATION OF CHRIS ALSTON'S CHASSISWORKS, INC. AND SHALL NOT BE REPRODUCED, TRANSFERRED TO OTHER DOCUMENTS, DISCLOSED TO OTHERS, USED FOR MANUFACTURING, OR FOR ANY OTHER PURPOSE, IN WHOLE OR IN PART WITHOUT PRIOR WRITTEN PERMISSION OF CHRIS ALSTON'S CHASSISWORKS, INC.

REVISIONS				
ZONE	REV	DESCRIPTION	DATE	APPROVED

132

ITEM	QTY	PART NO.	DESCRIPTION
1	1	7972-2466-37	4 x 2 REAR CLIP, 37" WIDE, COILOVER SHOCK, 70-81 CAMARO G-STREET
2	1	5603-51	gSTREET FRONT CLIP, STD MTR MNT, 70-73 CAMARO/FIREBIRD
3	1	7972-2226	CROSSMEMBER WELDMENT, SEAT MOUNT, gSTREET, 70-81 CAMARO
4	2	7972-2152	SUBFRAME CONNECTOR, PRO/TOURING, F10
5	1	7972-2258	ROCKER ASSEMBLY, DRIVER, gSTREET CAMARO, F20
6	1	7972-2259	ROCKER ASSEMBLY, PASSENGER, gSTREET CAMARO, F20
7	2	7972-2378	HANGER MOUNT, REAR VALANCE, CANTED 4-BAR, F20
8	1	7972-2376	FILLER PANEL, REAR VALANCE, DRIVER, 70-?? CAMARO
9	1	7972-2377	FILLER PANEL, REAR VALANCE, PASSENGER, 70-?? CAMARO
10	1	4871-01-1	MAIN HOOP, PRO/TOURING F2 CAMARO
11	1	4871-12-1	REAR STRUT, DRIVER PRO/TOURING F2 CAMARO
12	1	4871-13-1	REAR STRUT, PASSENGER, PRO/TOURING F2 CAMARO
13	2	4871-18-7	REAR STRUT SUPPORT, IRS, F20
14	4	1146	JOINT PLUG $\varnothing$ 1.95 OD FLAT
15	2	2840	BRACKET, BACKBRACE, 1 3/4 TUBE, 3/8 x 1/2 HOLE x 2.13 CENTER
16	1	7051-F20-1	SIDE BAR, REMOVABLE, DRIVER, F20, PRO/TOURING CAMARO
17	1	7051-F20-2	SIDE BAR, REMOVABLE, PSGR, F20, PRO/TOURING CAMARO
18	2	7972-2120	BRACKET, FORWARD STRUT, WELD-ON, F10
19	2	2839	BRACKET, FIREWALL TAB, 3/8 x 1/2 HOLE x 1.25 EDGE TO HOLE
20	1	7051-F10-4	FORWARD STRUT, DRIVER, PRO/TOURING CAMARO
21	1	7051-F10-5	FORWARD STRUT, PSGR, PRO/TOURING CAMARO
22	2	7972-2170	COVER, WIREWAY, REAR ROCKER, NEW, CANTED 4-BAR, F10
23	4	3108-019L-C	LOCK WASHER, HELICAL SPRING #10, STEEL, ZINC
24	4	3104-019F0.38S	BUTTON HEAD SOCKET CAP SCREW 10-32 x 3/8, STAINLESS STEEL
25	2	7972-2389	PLATFORM, ROCKER PANEL, A-PILLAR, F20

UNLESS OTHERWISE SPECIFIED		APPROVALS	DATE	DESCRIPTION <b>gSTREET, 70-81 CAMARO, FULL FRAME, COILOVER IRS, MARK-II FRONT CLIP</b>
DIMENSIONS ARE IN INCHES TOLERANCES FRACTIONS ANGLES DECIMAL $\pm$ 1/16 $\pm$ $\varnothing$ $\pm$ .1 $\pm$ .05 $\pm$ .01 $\pm$ .005 $\pm$ .005 $\pm$ .0010		DRAWN BY: D.HOESCHEN	2/19/18	
		CHECKED BY: S. RIEGER	2/19/18	Chris Alston's CHASSISWORKS INC. 8661 YOUNGER CREEK DRIVE SACRAMENTO, CA 95828 (916) 388-0288 FAX 388-0295
		DWG RELEASE LEVEL: In Work		
FINISH	NONE			SIZE
MATERIAL	ASSEMBLY			PART NO.
				<b>7742-F20</b>
				PART REV.
				<b>0</b>
SCALE: 1:16		DWG: 7951-7742F20 REV: 0.1		SHEET 3 OF 5

ROLL BAR

# Coil-Over IRS Chassis

THIS DRAWING CONTAINS PROPRIETARY INFORMATION OF CHRIS ALSTON'S CHASSISWORKS, INC. AND SHALL NOT BE REPRODUCED, TRANSFERRED TO OTHER DOCUMENTS, DISCLOSED TO OTHERS, USED FOR MANUFACTURING, OR FOR ANY OTHER PURPOSE, IN WHOLE OR IN PART WITHOUT PRIOR WRITTEN PERMISSION OF CHRIS ALSTON'S CHASSISWORKS, INC.

REVISIONS				
ZONE	REV	DESCRIPTION	DATE	APPROVED

133

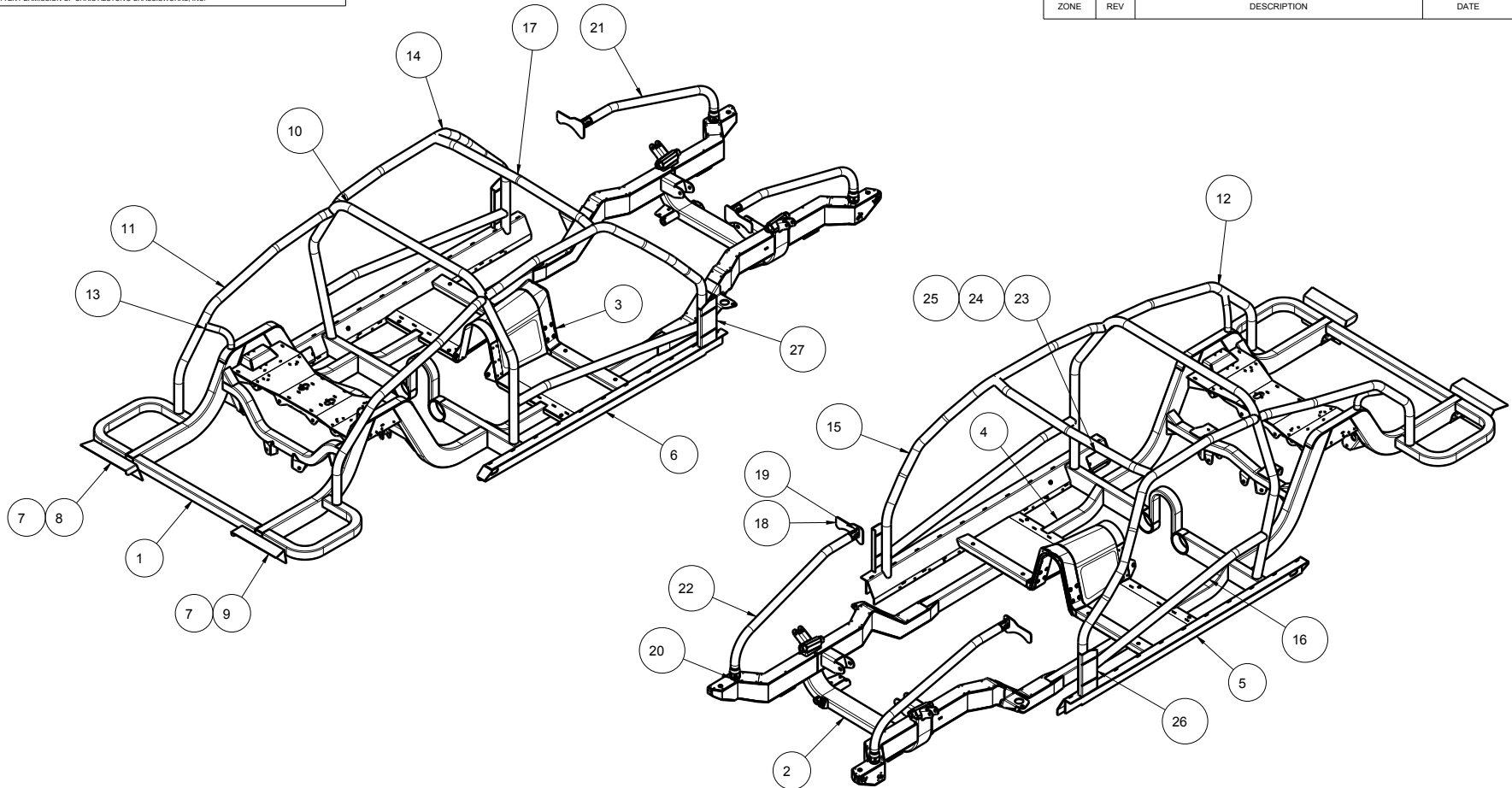

UNLESS OTHERWISE SPECIFIED		APPROVALS	DATE	DESCRIPTION
DIMENSIONS ARE IN INCHES TOLERANCES FRACTIONS ANGLES DECIMAL ± 1/16 ± ° ± .1 ± .05 ± .01 ± .005 ± .005 ± .0010		DRAWN BY: D.HOESCHEN	2/19/18	7081 STREET, 70-81 CAMARO, FULL FRAME, COILOVER IRS, MARK-II FRONT CLIP
FINISH NONE		CHECKED BY: S. RIEGER	2/19/18	
MATERIAL ASSEMBLY		DWG RELEASE LEVEL: In Work		Chris Alston's CHASSISWORKS INC. 8661 YOUNGER CREEK DRIVE SACRAMENTO, CA 95828 (916) 388-0288 FAX 388-0295
SIZE B	PART NO. 7742-F20	PART REV. 0		SCALE: 1:20 DWG: 7951-7742F20 REV: 0.1 SHEET 4 OF 5

# Coil-Over IRS Chassis

THIS DRAWING CONTAINS PROPRIETARY INFORMATION OF CHRIS ALSTON'S CHASSISWORKS, INC. AND SHALL NOT BE REPRODUCED, TRANSFERRED TO OTHER DOCUMENTS, DISCLOSED TO OTHERS, USED FOR MANUFACTURING, OR FOR ANY OTHER PURPOSE, IN WHOLE OR IN PART WITHOUT PRIOR WRITTEN PERMISSION OF CHRIS ALSTON'S CHASSISWORKS, INC.

REVISIONS				
ZONE	REV	DESCRIPTION	DATE	APPROVED

ITEM	QTY	PART NO.	DESCRIPTION
1	1	7972-2466-37	4 x 2 REAR CLIP, 37" WIDE, COILOVER SHOCK, 70-81 CAMARO G-STREET
2	1	5603-51	gSTREET FRONT CLIP, STD MTR MNT, 70-73 CAMARO/FIREBIRD
3	1	7972-2226	CROSSMEMBER WELDMENT, SEAT MOUNT, gSTREET, 70-81 CAMARO
4	2	7972-2152	SUBFRAME CONNECTOR, PRO/TOURING, F10
5	1	7972-2258	ROCKER ASSEMBLY, DRIVER, gSTREET CAMARO, F20
6	1	7972-2259	ROCKER ASSEMBLY, PASSENGER, gSTREET CAMARO, F20
7	2	7972-2378	HANGER MOUNT, REAR VALANCE, CANTED 4-BAR, F20
8	1	7972-2376	FILLER PANEL, REAR VALANCE, DRIVER, 70-?? CAMARO
9	1	7972-2377	FILLER PANEL, REAR VALANCE, PASSENGER, 70-?? CAMARO
10	1	4871-01-1	MAIN HOOP, PRO/TOURING F2 CAMARO
11	1	4871-12-1	REAR STRUT, DRIVER PRO/TOURING F2 CAMARO
12	1	4871-13-1	REAR STRUT, PASSENGER, PRO/TOURING F2 CAMARO
13	2	4871-18-7	REAR STRUT SUPPORT, IRS, F20
14	1	4871-10-1	CAGE SIDE, THRU DASH, DRV, PRO/TOURING F2 CAMARO
15	1	4871-11-1	CAGE SIDE, THRU DASH, PSGR, PRO/TOURING F2 CAMARO
16	2	4871-17-1	SIDE BAR, ROLL CAGE, F20
17	1	4871-04-1	WINDSHIELD BRACE, PRO/TOURING F2 CAMARO
18	2	7972-2120	BRACKET, FORWARD STRUT, WELD-ON, F10
19	2	2839	BRACKET, FIREWALL TAB, 3/8 x 1/2 HOLE x 1.25 EDGE TO HOLE
20	2	1146	JOINT PLUG $\varnothing$ 1.95 OD FLAT
21	1	7051-F10-4	FORWARD STRUT, DRIVER, PRO/TOURING CAMARO
22	1	7051-F10-5	FORWARD STRUT, PSGR, PRO/TOURING CAMARO
23	2	7972-2170	COVER, WIREWAY, REAR ROCKER, NEW, CANTED 4-BAR, F10
24	4	3108-019L-C	LOCK WASHER, HELICAL SPRING #10, STEEL, ZINC
25	4	3104-019F0.38S	BUTTON HEAD SOCKET CAP SCREW 10-32 x 3/8, STAINLESS STEEL
26	1	7972-2265	CAGE SIDE NOTCH, DRIVER, 70-81 CAMARO gSTREET
27	1	7972-2266	CAGE SIDE NOTCH, PSGR, 70-81 CAMARO gSTREET

134

ROLL CAGE

UNLESS OTHERWISE SPECIFIED		APPROVALS	DATE	DESCRIPTION
DIMENSIONS ARE IN INCHES TOLERANCES FRACTIONS ANGLES DECIMAL $\pm$ 1/16 $\pm$ $\frac{\circ}{16}$ $\pm$ .1 $\pm$ .05 $\pm$ .01 $\pm$ .005 $\pm$ .005 $\pm$ .0010		DRAWN BY: D. HOESCHEN	2/19/18	
		CHECKED BY: S. RIEGER	2/19/18	Chris Alston's CHASSISWORKS INC. 8661 YOUNGER CREEK DRIVE SACRAMENTO, CA 95828 (916) 388-0288 FAX 388-0295
FINISH NONE		DWG RELEASE LEVEL: In Work		
MATERIAL ASSEMBLY				B 7742-F20
		SCALE: 1:16		DWG: 7951-7742F20 REV: 0.1 SHEET 5 OF 5
				PART REV. 0



# Rocker-Arm IRS Chassis

THIS DRAWING CONTAINS PROPRIETARY INFORMATION OF CHRIS ALSTON'S CHASSISWORKS, INC. AND SHALL NOT BE REPRODUCED, TRANSFERRED TO OTHER DOCUMENTS, DISCLOSED TO OTHERS, USED FOR MANUFACTURING, OR FOR ANY OTHER PURPOSE, IN WHOLE OR IN PART WITHOUT PRIOR WRITTEN PERMISSION OF CHRIS ALSTON'S CHASSISWORKS, INC.

REVISIONS				
ZONE	REV	DESCRIPTION	DATE	APPROVED

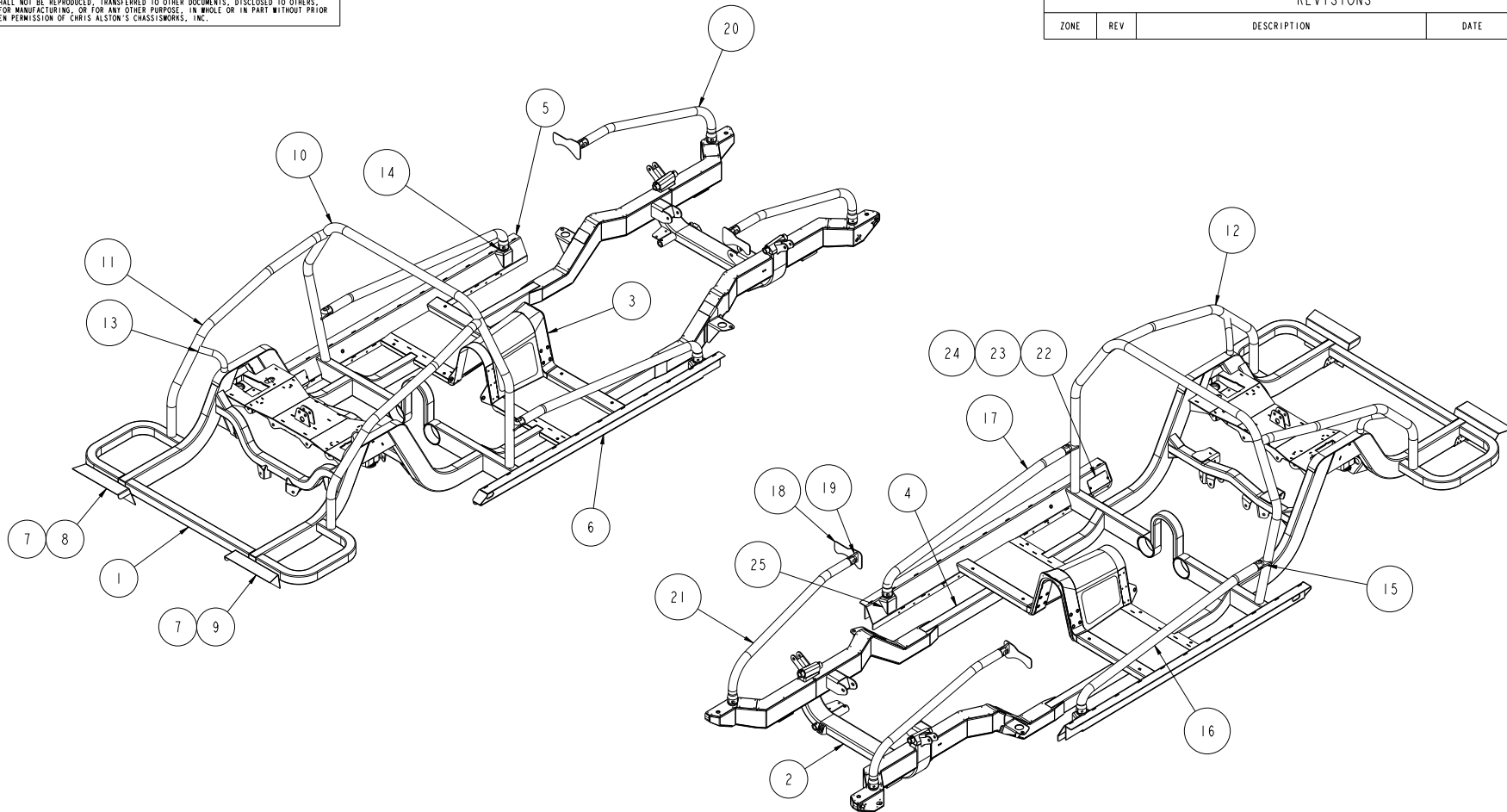

136

UNLESS OTHERWISE SPECIFIED		APPROVALS	DATE	DESCRIPTION <b>95 STREET, 70-81 CAMARO, FULL FRAME, IRS GEN2, MARK-II FRONT CLIP</b>
DIMENSIONS ARE IN INCHES		DRAWN BY: D. HOESCHEN	9/8/17	
TOLERANCES		CHECKED BY: S. RIEGER	4/15/20	
FRACTIONS ±1/16	ANGLES ±.5° ±.005	DECIMAL ±.1 ±.01 ±.005 ±.0010	DWG RELEASE LEVEL: In Work	Chris Alston's CHASSISWORKS INC. 8661 YOUNGER CREEK DRIVE SACRAMENTO, CA 95828 (916) 388-0288 FAX 388-0295
FINISH NONE	MATERIAL ASSEMBLY	SIZE B	PART NO. <b>7743-F20</b>	PART REV. <b>0</b>
SCALE: 1:20		DWG: 7951-7743F20	REV: 0.1	SHEET 2 OF 5

# Rocker-Arm IRS Chassis

THIS DRAWING CONTAINS PROPRIETARY INFORMATION OF CHRIS ALSTON'S CHASSISWORKS, INC. AND SHALL NOT BE REPRODUCED, TRANSFERRED TO OTHER DOCUMENTS, DISCLOSED TO OTHERS, USED FOR MANUFACTURING, OR FOR ANY OTHER PURPOSE, IN WHOLE OR IN PART WITHOUT PRIOR WRITTEN PERMISSION OF CHRIS ALSTON'S CHASSISWORKS, INC.

REVISIONS				
ZONE	REV	DESCRIPTION	DATE	APPROVED

ITEM	QTY	PART NO.	DESCRIPTION
1	1	7972-2390-37	4 x 2 REAR CLIP, 37" WIDE, ROCKER SHOCK, 70-81 CAMARO G-STREET
2	1	5603-51	gSTREET FRONT CLIP, LTI GEN-V, 70-81 CAMARO/FIREBIRD
3	1	7972-2226	CROSSMEMBER WELDMENT, SEAT MOUNT, gSTREET, 70-81 CAMARO
4	2	7972-2152	SUBFRAME CONNECTOR, PRO/TOURING, F10
5	1	7972-2258	ROCKER ASSEMBLY, DRIVER, gSTREET CAMARO, F20
6	1	7972-2259	ROCKER ASSEMBLY, PASSENGER, gSTREET CAMARO, F20
7	2	7972-2378	HANGER MOUNT, REAR VALANCE, CANTED 4-BAR, F20
8	1	7972-2376	FILLER PANEL, REAR VALANCE, DRIVER, 70-?? CAMARO
9	1	7972-2377	FILLER PANEL, REAR VALANCE, PASSENGER, 70-?? CAMARO
10	1	4871-01-1	MAIN HOOP, PRO/TOURING F2 CAMARO
11	1	4871-12-1	REAR STRUT, DRIVER PRO/TOURING F2 CAMARO
12	1	4871-13-1	REAR STRUT, PASSENGER, PRO/TOURING F2 CAMARO
13	2	4871-18-7	REAR STRUT SUPPORT, IRS, F20
14	4	1146	JOINT PLUG Ø1.95 OD FLAT
15	2	2840	BRACKET, BACKBRACE, 1 3/4 TUBE, 3/8 x 1/2 HOLE x 2.13 CENTER
16	1	7051-F20-1	SIDE BAR, REMOVABLE, DRIVER, F20, PRO/TOURING CAMARO
17	1	7051-F20-2	SIDE BAR, REMOVABLE, PSGR, F20, PRO/TOURING CAMARO
18	2	7972-2120	BRACKET, FORWARD STRUT, WELD-ON, F10
19	2	2839	BRACKET, FIREWALL TAB, 3/8 x 1/2 HOLE x 1.25 EDGE TO HOLE
20	1	7051-F10-4	FORWARD STRUT, DRIVER, PRO/TOURING CAMARO
21	1	7051-F10-5	FORWARD STRUT, PSGR, PRO/TOURING CAMARO
22	2	7972-2170	COVER, WIREWAY, REAR ROCKER, NEW, CANTED 4-BAR, F10
23	4	3108-019L-C	LOCK WASHER, HELICAL SPRING #10, STEEL, ZINC
24	4	3104-019F0.38S	BUTTON HEAD SOCKET CAP SCREW 10-32 x 3/8, STAINLESS STEEL
25	2	7972-2389	PLATFORM, ROCKER PANEL, A-PILLAR, F20

137

ROLL BAR

UNLESS OTHERWISE SPECIFIED		APPROVALS	DATE	<b>gSTREET, 70-81 CAMARO, FULL FRAME, IRS GEN2, MARK-II FRONT CLIP</b> Chris Alston's CHASSISWORKS INC. 8661 YOUNGER CREEK DRIVE SACRAMENTO, CA 95828 (916) 388-0288 FAX 388-0295					
DIMENSIONS ARE IN INCHES TOLERANCES FRACTIONS ±1/16 ANGLES ±.5° DECIMAL ±.01 ±.05 ±.005 ±.0010		DRAWN BY: D. HOESCHEN	9/8/17						
		CHECKED BY: S. RIEGER	4/15/20						
		DWG RELEASE LEVEL: In Work							
FINISH	NONE			SIZE	PART NO.	7743-F20	PART REV.	0	
MATERIAL	ASSEMBLY			SCALE:	1:16	DWG:	7951-7743F20	REV: 0.1	SHEET 3 OF 5

# Rocker-Arm IRS Chassis

THIS DRAWING CONTAINS PROPRIETARY INFORMATION OF CHRIS ALSTON'S CHASSISWORKS, INC. AND SHALL NOT BE REPRODUCED, TRANSFERRED TO OTHER DOCUMENTS, DISCLOSED TO OTHERS, USED FOR MANUFACTURING, OR FOR ANY OTHER PURPOSE, IN WHOLE OR IN PART WITHOUT PRIOR WRITTEN PERMISSION OF CHRIS ALSTON'S CHASSISWORKS, INC.

REVISIONS				
ZONE	REV	DESCRIPTION	DATE	APPROVED

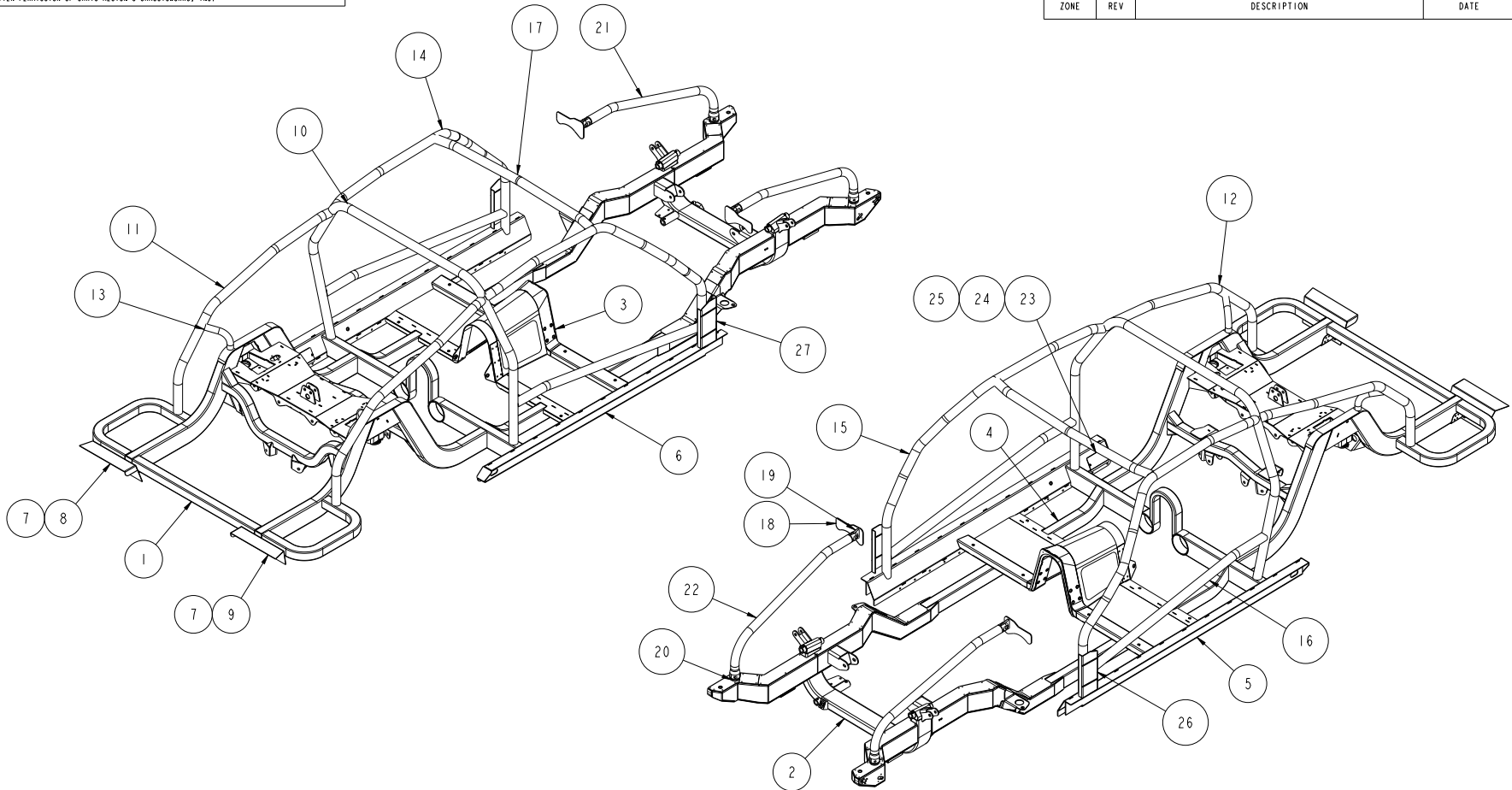

138

UNLESS OTHERWISE SPECIFIED		APPROVALS	DATE	DESCRIPTION <b>95 STREET, 70-81 CAMARO, FULL FRAME, IRS GEN2, MARK-II FRONT CLIP</b>
DIMENSIONS ARE IN INCHES		DRAWN BY: D. HOESCHEN	9/8/17	
TOLERANCES		CHECKED BY: S. RIEGER	4/15/20	
FRACTIONS ±1/16	ANGLES ±.5° ±.005	DECIMAL ±.1 ±.01 ±.005 ±.0010	DWG RELEASE LEVEL: In Work	Chris Alston's CHASSISWORKS INC. 8661 YOUNGER CREEK DRIVE SACRAMENTO, CA 95828 (916) 388-0288 FAX 388-0295
FINISH NONE	MATERIAL ASSEMBLY	SIZE B	PART NO. <b>7743-F20</b>	PART REV. <b>0</b>
SCALE: 1:20		DWG: 7951-7743F20	REV: 0.1	SHEET 4 OF 5



# IRS Chassis - Rear Floor

140

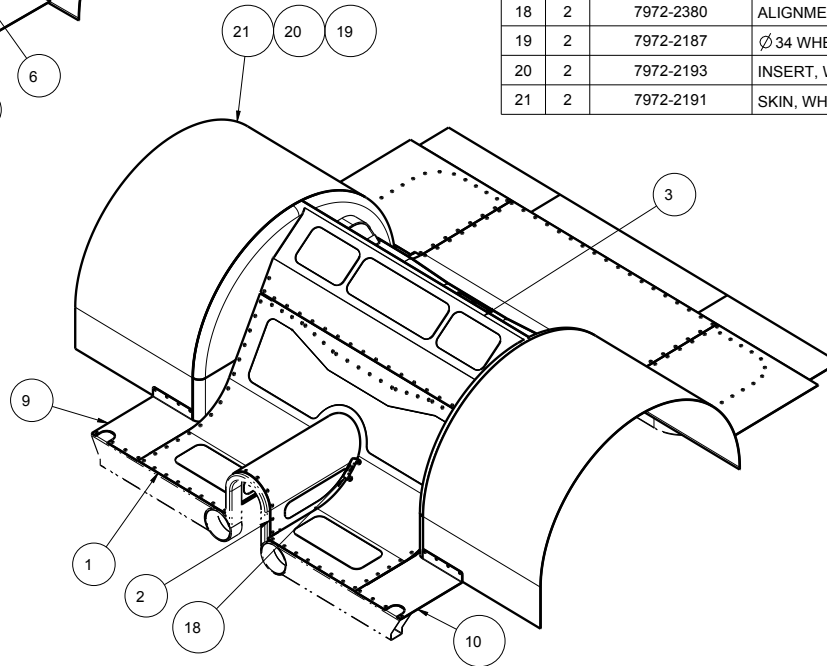
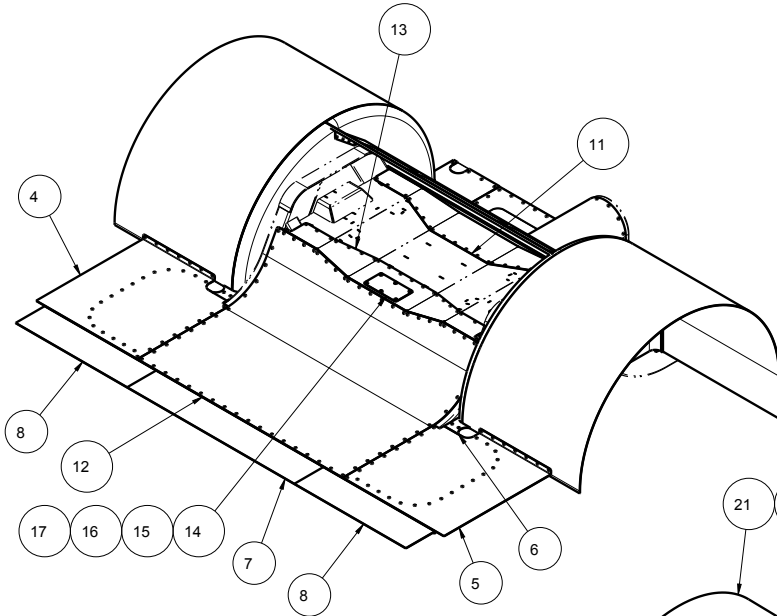

ITEM	QTY	PART NO.	DESCRIPTION
1	1	7972-2479-37	REAR FLOOR, AXLE FRONT, IRS GEN2, F20, 37 WIDE
2	1	7972-2364	REAR TUNNEL TERMINATION, IRS, F20
3	1	7972-2480-37	BULKHEAD, REAR FIREWALL, IRS GEN2, F20, 37 WIDE
4	1	7972-2372	REAR TRUNK FLOOR, DRIVER, IRS, F20
5	1	7972-2373	REAR TRUNK FLOOR, PASSENGER, IRS, F20
6	2	7972-2374	FILLER, TRUNK, IRS, F20
7	1	7972-2361	REAR FLOOR FILLER, TRUNK, CENTER, IRS, F20
8	2	7972-2362	REAR FLOOR FILLER, TRUNK, OUTBOARD, IRS, F20
9	1	7972-2366	REAR FLOOR FILLER, FRONT AXLE, OUTBOARD PSGR, IRS, F20
10	1	7972-2365	REAR FLOOR FILLER, FRONT AXLE, OUTBOARD DRV, IRS, F20
11	1	7972-2481-37	FILLER PANEL, FRONT, IRS GEN2 CROSSMEMBER, F20, 37 WIDE
12	1	7972-2483-37	TRUNK FLOOR, IRS GEN2, F20, 37 WIDE
13	1	7972-2482-37	FILLER PANEL, REAR, IRS GEN2 CROSSMEMBER, F10 / F20, 37 WIDE
14	1	7972-2375	COVER, RESERVOIR POCKET, IRS
15	6	3104-019F0.50S	BUTTON HEAD SOCKET CAP SCREW 10-32 x 1/2, STAINLESS STEEL
16	6	3157-019S-S	WASHER, #10 SAE, STAINLESS, 7/32 ID x .716 OD x 3/64 THICK
17	6	3101-019-32S	LOCKNUT 10-32, GRADE 5, STAINLESS STEEL
18	2	7972-2380	ALIGNMENT TOOL, FLOOR TO TUNNEL, IRS
19	2	7972-2187	Ø34 WHEEL TUB CAP
20	2	7972-2193	INSERT, WHEEL TUB CORNER
21	2	7972-2191	SKIN, WHEEL TUB, Ø34 x 60 LONG, 3.30 STRAIGHT, 20 WIDE

DESCRIPTION		FLOOR KIT, REAR, IRS GEN2, gSTREET, 70-81 CAMARO	
Chris Alston's CHASSISWORKS INC. 8661 YOUNGER CREEK DRIVE SACRAMENTO, CA 95828 (916) 388-0288 FAX 388-0295		PART NO.	7742-F20-R
9/28/17	DWG: 7951-7742F20R		

# All Chassis Styles - Front Floor

Sheet 1 of 1

141

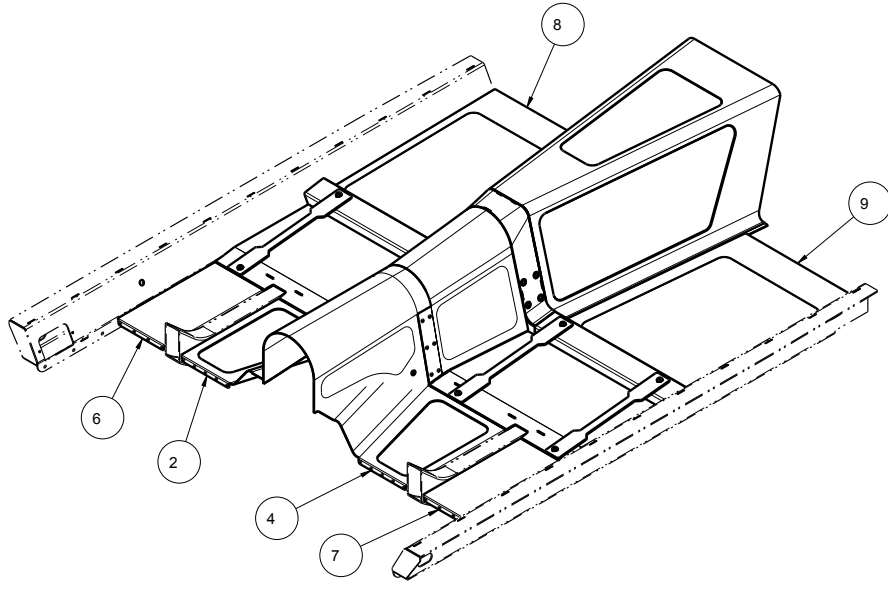

ITEM	QTY	PART NO.	DESCRIPTION
1	1	7972-2226	CROSSMEMBER WELDMENT, SEAT MOUNT, gSTREET, 70-81 CAMARO
2	1	7972-2251	FLOOR, REAR SEAT, INBOARD DRIVER, gSTREET CAMARO, F20
3	1	7972-2253	TUNNEL, REAR SEAT, gSTREET, F20
4	1	7972-2252	FLOOR, REAR SEAT, INBOARD PSGR, gSTREET CAMARO, F20
5	1	7972-2250	TUNNEL, FIREWALL TRANSITION, CANTED 4-BAR, F20
6	1	7972-2243	FLOOR, REAR SEAT, OUTBOARD DRIVER, gSTREET CAMARO, F20
7	1	7972-2244	FLOOR, REAR SEAT, OUTBOARD PSGR, gSTREET CAMARO, F20
8	1	7972-2241	FLOOR, FRONT DRIVER, gSTREET CAMARO, F20
9	1	7972-2242	FLOOR, FRONT PASSENGER, gSTREET CAMARO, F20
10	4	7972-2116	MOUNTING PLATE, SEAT ADJUSTER RAIL, CANTED 4-BAR, F10
11	8	3108-031L-C	LOCK WASHER, HELICAL SPRING Ø5/16, STEEL, ZINC
12	8	3104-031C0.75C	BUTTON HEAD SOCKET CAP SCREW, 5/16-18 x 3/4, CLEAR ZINC

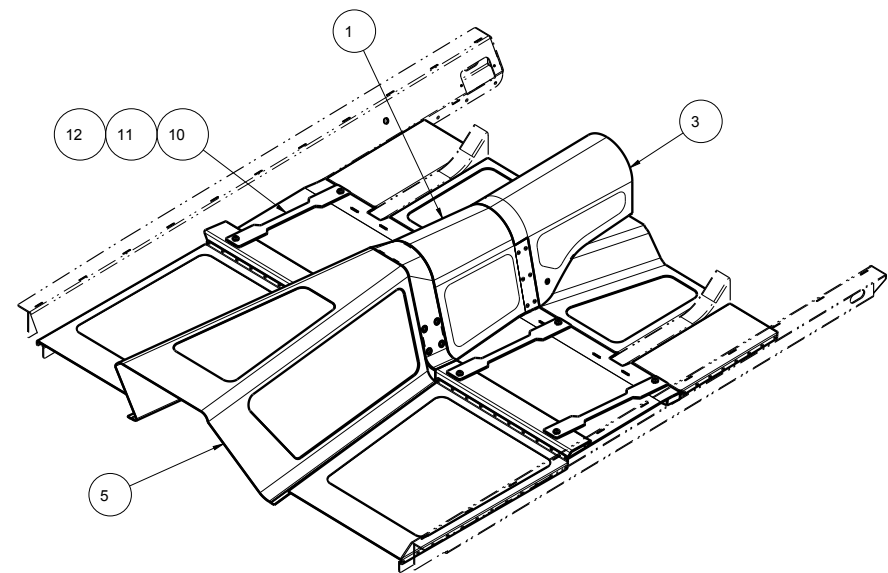

DESCRIPTION		FLOOR KIT, FRONT, gSTREET, 70-81 CAMARO	
Chris Alston's CHASSISWORKS INC. 8661 YOUNGER CREEK DRIVE SACRAMENTO, CA 95828 (916) 388-0288 FAX 388-0295		PART NO.	7740-F20-F
		3/23/17	DWG: 7951-7740F20F

## NOTES:

## NOTES:

**WARRANTY NOTICE:**

There are NO WARRANTIES, either expressed or implied. Neither the seller nor manufacturer will be liable for any loss, damage or injury, direct or indirect, arising from the use or inability to determine the appropriate use of any products. Before any attempt at installation, all drawings and/or instruction sheets should be completely reviewed to determine the suitability of the product for its intended use. In this connection, the user assumes all responsibility and risk. We reserve the right to change specification without notice. Further, Chris Alston's Chassisworks, Inc., makes **NO GUARANTEE** in reference to any specific class legality of any component. **ALL PRODUCTS ARE INTENDED FOR RACING AND OFF-ROAD USE AND MAY NOT BE LEGALLY USED ON THE HIGHWAY.** The products offered for sale are true race-car components and, in all cases, require some fabrication skill. **NO PRODUCT OR SERVICE IS DESIGNED OR INTENDED TO PREVENT INJURY OR DEATH.**

Chris Alston's Chassisworks  
8661 Younger Creek Drive  
Sacramento, CA 95828  
Phone: 916-388-0288  
Technical Support: [sales@cachassisworks.com](mailto:sales@cachassisworks.com)

