

## g-Street™ 11-3/4" Vented Iron Rotor-Hub with Forged-Aluminum 4-Piston Caliper



### Features

- 11-3/4" x .81" one-piece iron rotor-hub (vented, drilled, slotted) with black E-coat finish
- Wilwood Dynalite 4-piston (stainless), aluminum-body calipers
- Wilwood Dynapro 4-piston (aluminum with dust boots), aluminum-body calipers
- 2" wheel studs

### Applications

#### Chassisworks Spindles

- Sculpted Iron (6174, 6186)
- Drag Race Fabricated (6165, 6166)
- VariStrut (all integral spindle versions)

#### OEM and Aftermarket Spindles

- '64-72 GM A-, F-, X-Body
- '74-78 Ford Mustang II

## Front Disc Brakes - 11-3/4" Street

Chassisworks' designed and manufactured front disc brake kit features fixed, four-piston, forged-aluminum Wilwood calipers and 11.75 x .81" vented iron rotors with integrated hat and hub. The one-piece rotor assembly provides an economically brake option with excellent performance. Rotors are black E-coated and feature a drilled and slot-grooved abrasion surface to wipe the pads free of debris, reduce pad float if overheated, and enhance appearance. Our enhanced-friction ceramic-formula brake pads provide smooth engagement and long service life, with low noise and brake-dust levels for performance driving applications. The kit is designed for use in a variety of applications, including Chassisworks sculpted iron and fabricated spindles, OEM Mustang II and GM A-, F- and X-body spindles, as well as the drag race VariStrut offered through Chassisworks in-house shock brand, VariShock. Kits require 15" or larger wheels.

## Forged Dynalite Internal Caliper

The Forged Billet Dynalite Internal is the next generation enhancement of the venerable Forged Dynalite series calipers. Designed with a single split bridge and spacer less design to enhance strength and appearance. These latest applied developments and innovations in caliper design and manufacturing processes have resulted in substantial improvements in strength and performance over all comparable models. This new spacer-less design of the Forged Dynalite series of calipers, makes this the stiffest and most visual pleasing design so far.



- 4 stainless-steel pistons - 1.75" bore, 4.80 sq-in
- Forged aluminum caliper body - total weight 3.6 lbs
- Finishes - black or red powder coat

## Dynapro Dust-Boot Caliper

The Dynapro Dust-Boot (DP-DB) model of the Dynapro lug mount caliper was developed for applications that require or prefer a dust-booted piston. Dust-booted aluminum pistons provide added protection against road or track born dirt and debris on low to intermediate temperature range applications that may also operate in harsh environments. The pistons are clear anodized to eliminate corrosion while providing added lubricity for drag-free operation within the bores. The dust boots work in conjunction with high-temperature square faced internal seals in the caliper bores to provide optimum performance, ultimate reliability, and quick turn around at pad service intervals.



- 4 aluminum pistons - dust-boot, 1.75" bore, 4.80 sq-in
- Forged aluminum caliper body - total weight 3.8 lbs
- Finishes - black or red powder coat

## One-Piece Iron Hub-Rotor

Chassisworks developed this rotor as an economical option to provide great performance at a modest price for street and light-performance use vehicles. The vented, drilled and slotted design dissipates adequate heat for limited performance use such as street-strip or autocross.



- 11.75 x .81" iron rotor with integrated hat and hub
- 32 non-directional vanes
- Drilled and slotted
- Finish - black E-coat

## Chassisworks Spindles



### Brake Kits:

8319-BK - with black caliper

8319-RD - with red caliper

### Spindles:

6165, 6166, 6174, 6186

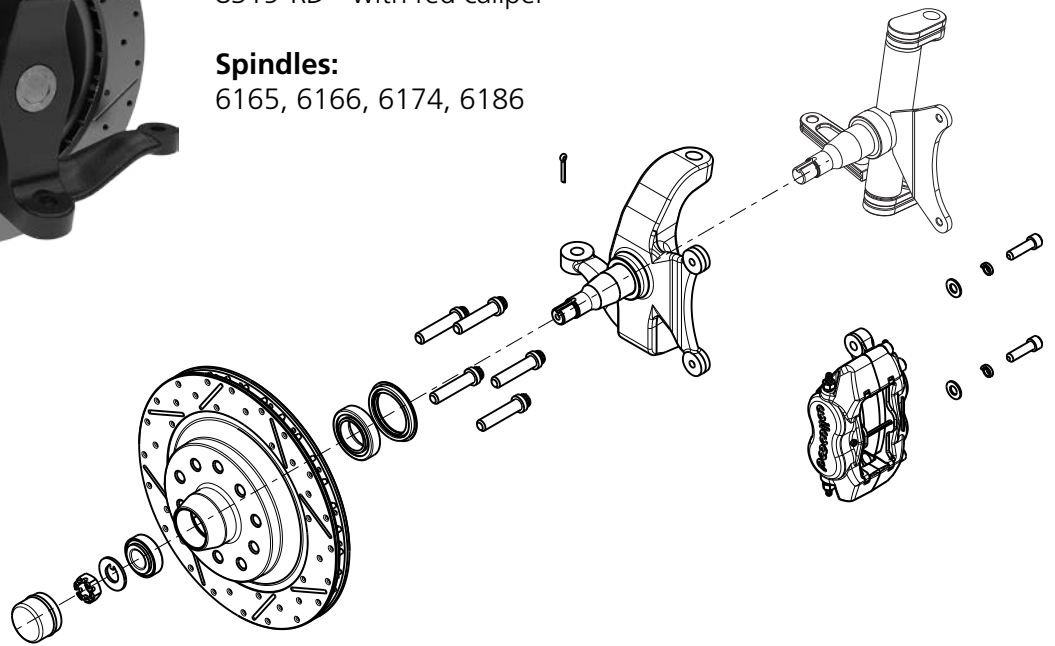

## Drag Race VariStrut



### Brake Kits:

8316-BK - with black caliper

8316-RD - with red caliper

### VariStruts:

All integral spindle struts

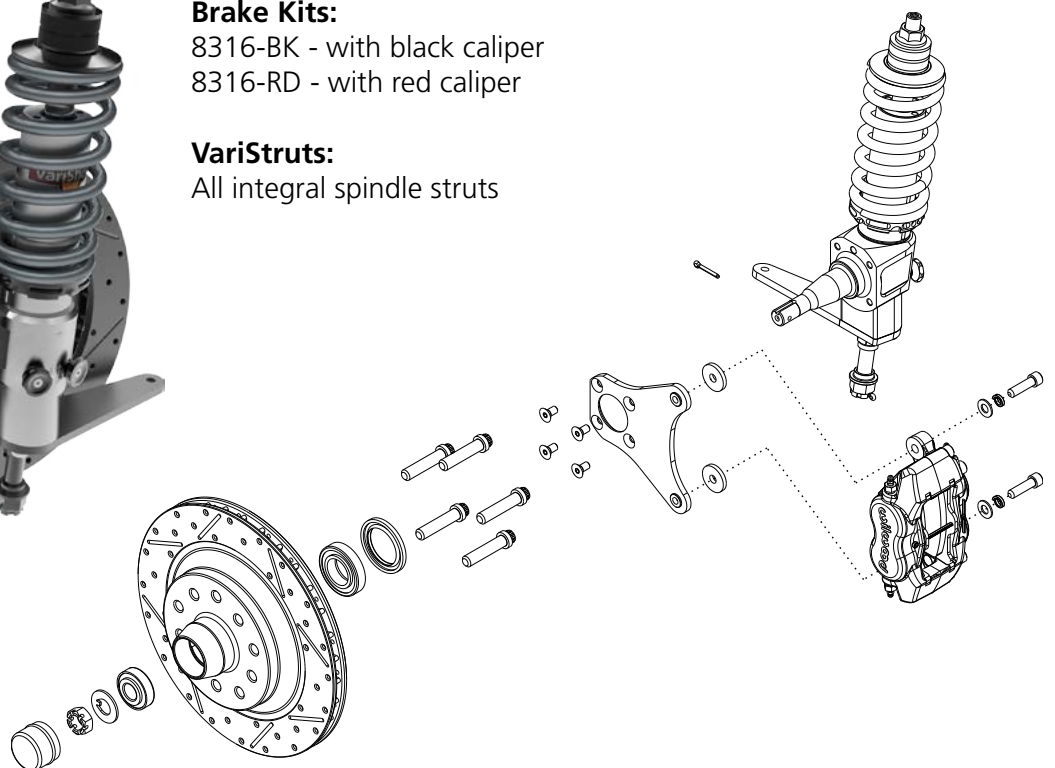

## Pinto/Mustang II Spindles



### Brake Kits:

8317-BK - with black caliper  
8317-RD - with red caliper

### Spindles:

Chassisworks - 5711-M30,  
5711-M30-2  
OEM '71-80 Pinto,  
'74-78 Mustang

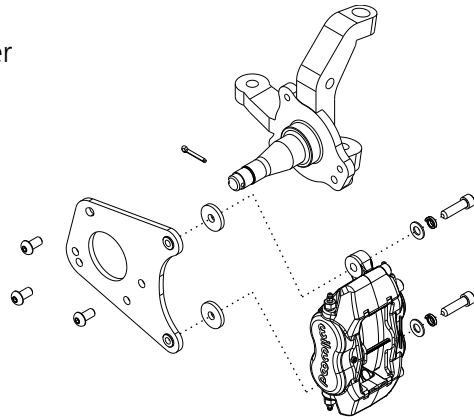
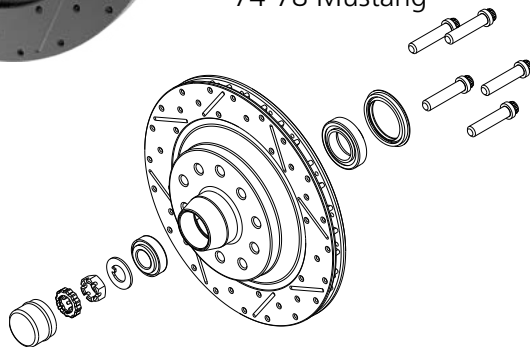

## A-, F-, X-Body Spindles



### Brake Kits:

8318DB-BK - with black dust-boot caliper  
8318DB-RD - with red dust-boot caliper  
8318-BK - with black caliper  
8318-RD - with red caliper

### Spindles:

Chassisworks - 5711-A10,  
5711-A10-2, 5711-A10-2T,  
5754-AFX-0, 5754-AFX-2  
OEM - '64-72 A-, F-, X-Body

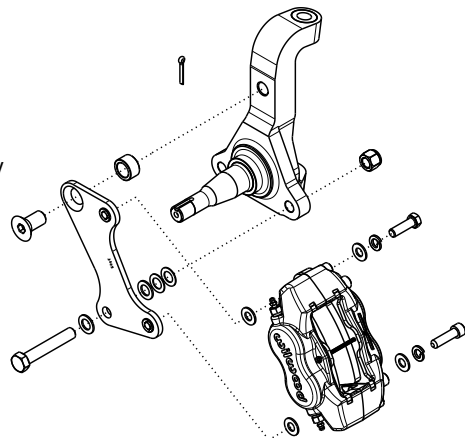
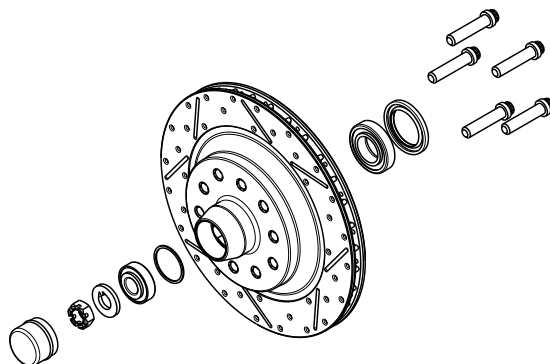

All prices subject to change. Current pricing available at [www.cachassisworks.com](http://www.cachassisworks.com).



Chris Alston's Chassisworks, Inc.  
8661 Younger Creek Drive  
Sacramento, CA 95828

Order: 800-722-2269  
Tech: 916-388-0288  
Fax: 916-388-0295

[sales@cachassisworks.com](mailto:sales@cachassisworks.com)  
[www.cachassisworks.com](http://www.cachassisworks.com)