

**g-Street™ 11-3/4" Vented Rotor
with Forged-Aluminum 4-Piston Caliper**



Matte-black-anodized caliper and clear-anodized hub shown.

Available with red, black, or polished caliper, clear-anodized or polished hub

Front Disc Brakes - Street

Chassisworks' designed and manufactured front disc brake kit features fixed, four-piston, forged-aluminum Wilwood calipers and 11.75 x .81" vented rotors with integrated hats and billet aluminum hubs. The bolt-together hub and rotor assembly allows worn or damaged components to be replaced easily and economically. Rotors are bare metal and feature a slot-grooved abrasion surface to wipe the pads free of debris, reduce pad float if overheated, and enhance appearance. Our enhanced-friction ceramic-formula brake pads provide smooth engagement and long service life, with low noise and brake-dust levels for performance driving applications. The kit is designed for use with g-Machine fabricated or sculpted spindles and requires 15" or larger wheels.

Forged Dynalite Caliper

Wilwood's Forged Dynalite (FDL) four-piston, aluminum, lug-mount caliper is used for its light weight (4.06 lb), superior rigidity, and enhanced braking performance and pedal feel. The calipers use a closed-end, internal fluid passage design that is further strengthened by four steel bridge bolts extending through the caliper body. Stress flow forging and smooth surface transitions help eliminate stress points and reduce overall caliper deflection.



Optional red caliper

FDL calipers use one-piece, 1.75"-diameter, stainless-steel pistons and high-temperature, square-faced bore seals. Stainless steel slows heat transfer to the brake fluid and improves the system's resistance to heat-induced pedal fade. This reduction in heat also increases the service life of the fluid and seals. The four individual pistons apply pressure against both sides of the rotor. Caliper

fluid requirements are matched to the output capabilities of commonly used factory master cylinders, ensuring comfortable performance in a wide range of applications.

The Dynalite calipers are trouble-free and service-friendly. Vibration-dampening stainless-steel bridge-plate inserts protect the caliper body from wear caused by pad movement, greatly extending service life. Two-piece bleed screws are easily accessed at each corner of the caliper body and eliminate direct wear to the aluminum body. Brake pads are also easily changed by simply removing the retaining pin and sliding the pads out.

High-Performance Rotors

The kit comes standard with vented, slot-grooved-surface rotors measuring 11.75 x .81". Rotors are bare metal and feature an integrated raised hat, increasing heat capacity to withstand extreme operating temperatures for extended periods of time; ideal for high-performance applications. To maximize cooling surface area, 32 individual air passages are cast internally into each rotor. Air passages or vents offer increased airflow and cooling capability over standard unvented rotor designs. The slotted surface grooves improve pad-to-rotor contact by wiping the pad clean of debris and allowing brake dust and gases to be easily exhausted if the pads are overheated.



Clear-Anodized Hub



Polished Hub

Billet Aluminum Hub

Billet aluminum hubs reduce unnecessary weight and allow components to be easily replaced if damaged or worn. Hubs are silver-anodized machine-finished with matching screw-on, O-ringed cap to prevent oxidation and resist scratching. Assemblies include both 4-1/2" and 4-3/4" five-lug bolt patterns with 1/2 x 2-1/4" wheel studs or optional 1/2 x 3" studs. Wheel bearings and seals also included.



Optional 3" Wheel Stud

Exploded Diagram

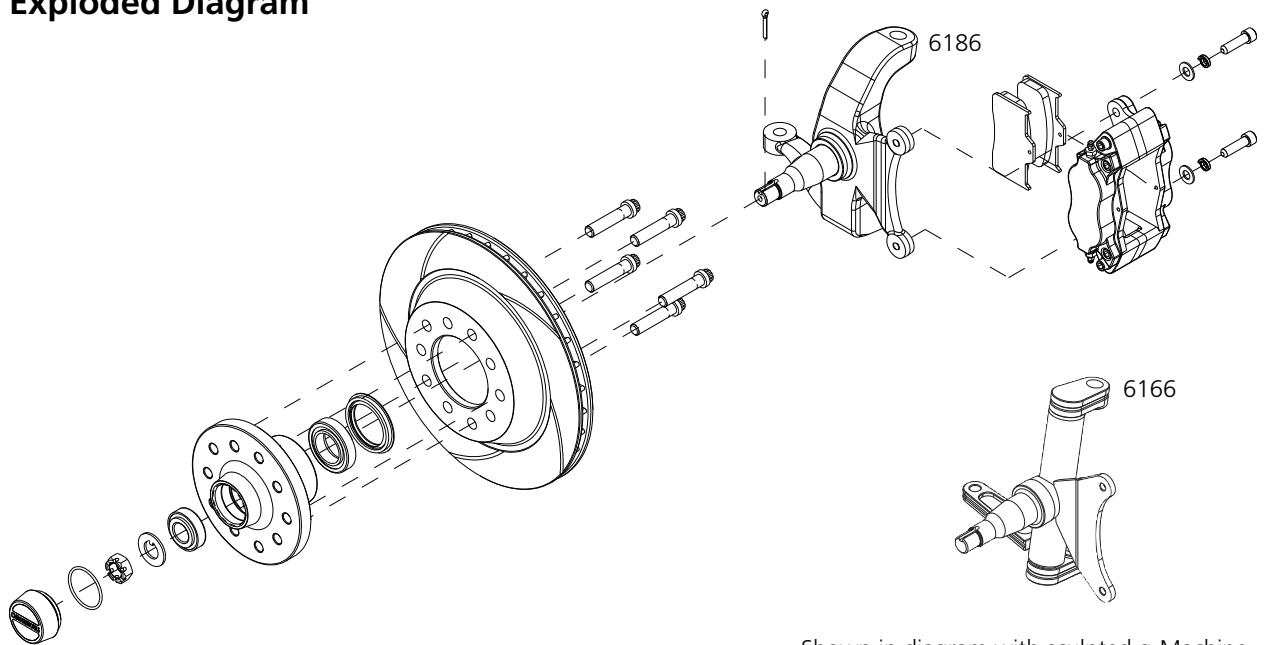

Shown in diagram with sculpted g-Machine spindle (6186); can also be used with fabricated spindle (6166) for drag racing.

Specifications

Caliper	Rotor	Hub
Model: Wilwood Dynalite Material: Forged Aluminum Pistons: 4 (1.75" Stainless Steel) Weight: 4.06 lb each Finish: Matte Black or Polished	Size: 11.75 x 0.81" Type: Vented, 32 Vanes Weight: 12.68 lb each Bare metal finish	Material: 6061-T65 Aluminum Bolt Patterns: 5 on 4-1/2" and 5 on 4-3/4" Weight: 4.45 lb each (with bearings and hardware) Finish: Clear-Anodized Machined Finish or Polished
Complete Kit Weight: 21.19 lb each side		

Pricing and Options

Part Number	Description
8324-12	g-Street 11-3/4" front disc brakes for g-Machine sculpted spindles (6186)
8327	g-Street 11-3/4" front disc brakes for '71-80 Pinto/Mustang II spindles
8332 ^{1,2}	g-Street 11-3/4" front disc brakes for '67-69 Camaro, '64-72 Chevelle, and '64-72 Chevy II/Nova drum and disc brake spindles
8337	g-Street 11-3/4" front disc brakes for Chassisworks fabricated drag-race spindles (6166)
8362 ²	g-Street 11-3/4" front disc brakes for '65-66 Impala/Biscayne spindles
8363	g-Street 11-3/4" front disc brakes for Drag Race VariStrut
OPTION	Red-finish calipers
OPTION	Polished-finish calipers
OPTION	Polished-finish hubs
OPTION	3"-long wheel studs
WW 150-8850K	Replacement pad set, street/strip standard, BP-10 compound, 100-1000 F°
Notes:	
All	Kits include uncoated vented rotor, matte-black calipers, and clear-anodized hubs.
1	1964 spindle requires simple modification.
2	Hub increases track width 5/8" per side.

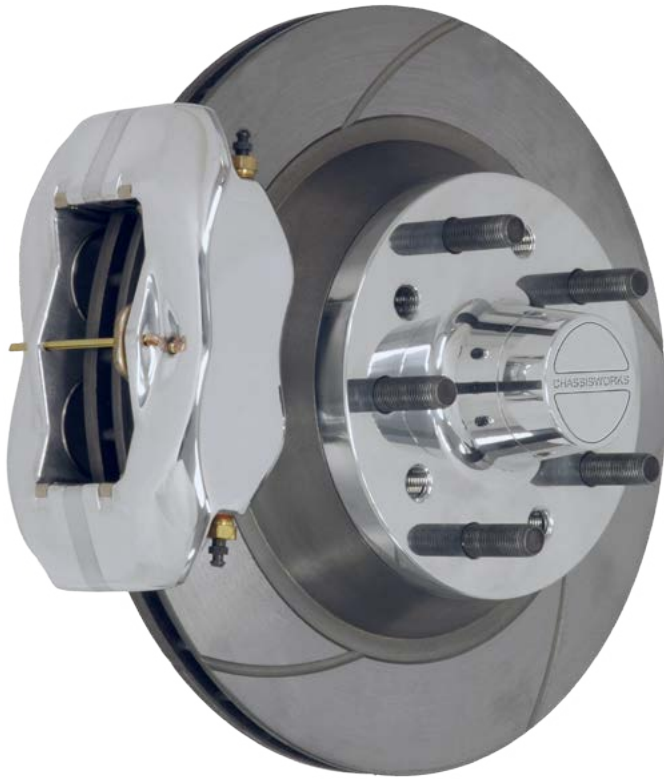

Optional Polished
Caliper and Hub

Standard Matte-Black-
Anodized Caliper and
Clear-Anodized Hub



All prices subject to change. Current pricing available at www.cachassisworks.com.



Chris Alston's Chassisworks, Inc.
8661 Younger Creek Drive
Sacramento, CA 95828

Order: 800-722-2269
Tech: 916-388-0288
Fax: 916-388-0295

sales@cachassisworks.com
www.cachassisworks.com