

DESCRIPTION	STRAIGHT 4 x 2 FRAME, TORQUE ARM & WATTS LINK	
<i>Chris Alston's</i> CHASSISWORKS INC. 8661 YOUNGER CREEK DRIVE SACRAMENTO, CA 95828 (916) 388-0288 FAX 388-0295	PART NO.	7751-U01
	6/1/18	DWG: 7951-7751U01

1	1	5762	FRONT SUSPENSION, STREET MACHINE
2	2	4554	4 x 2 A-ARM RAIL 6" GROUND CLEARANCE
3	2	4558	ROCKER SUPPORT TUBE, 2 x 4 A-ARM FRAME
4	1	7721-U01-38	4 x 2 REAR FRAME, TORQUE ARM, WATTS LINK, 38 OUTSIDE WIDTH
5	1	7972-5012	BUMPER MOUNT, DRIVER, PERIMETER FRAME
6	1	7972-5013	BUMPER MOUNT, PASSENGER, PERIMETER FRAME
7	2	B3224.120-30.00	TUBE, 3 x 2 x .120 WALL ERW x 30.00 LONG
8	1	7972-2608	ENGINE FRAME ADAPTER, DRV, UNIVERSAL 36 CROSSMEMBER
9	1	7972-2609	ENGINE FRAME ADAPTER, PSGR, UNIVERSAL 36 CROSSMEMBER

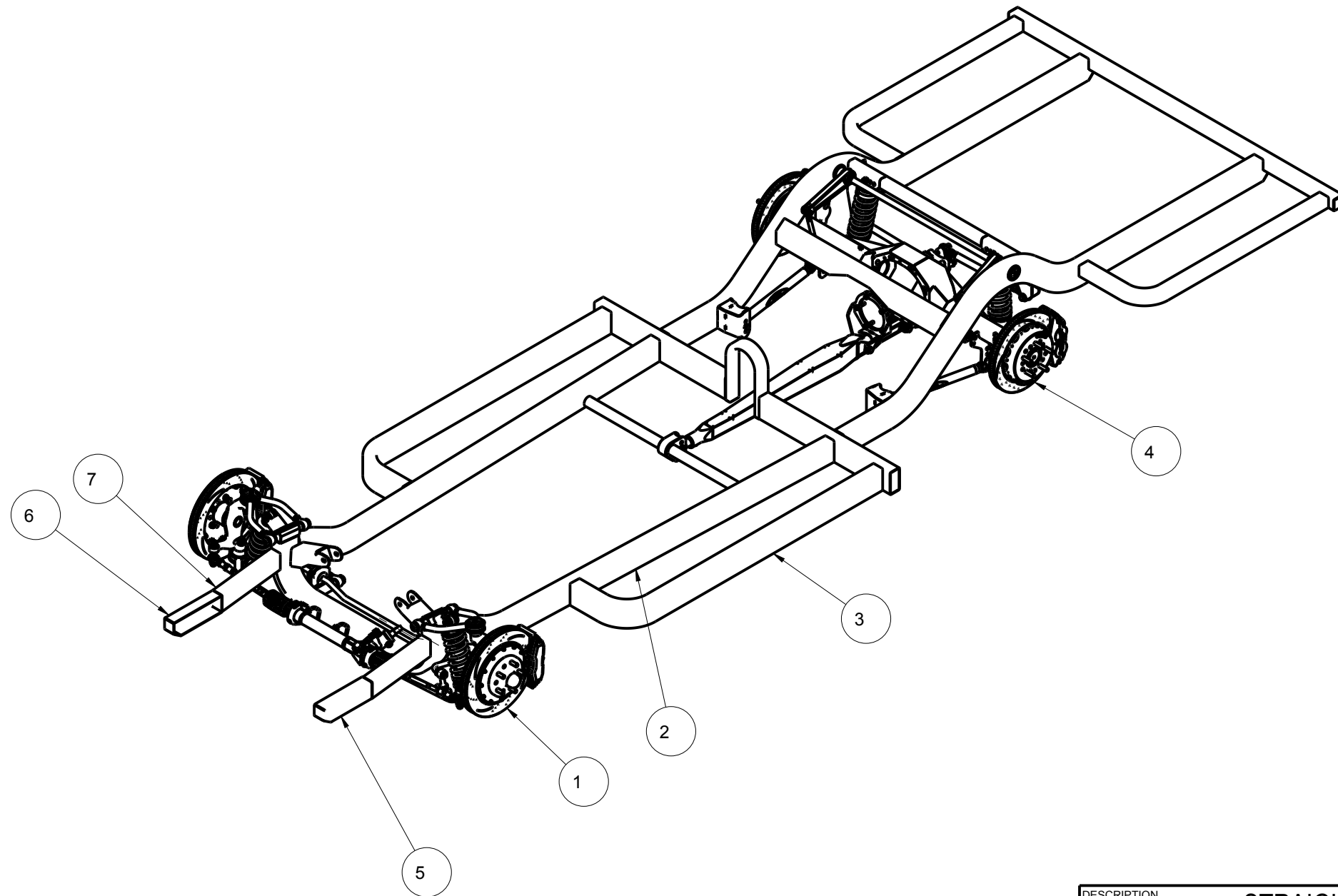

DESCRIPTION	STRAIGHT 4 x 2 FRAME, TORQUE ARM & WATTS LINK	
<i>Chris Alston's</i> CHASSISWORKS INC. 8661 YOUNGER CREEK DRIVE SACRAMENTO, CA 95828 (916) 388-0288 FAX 388-0295	PART NO.	7751-U01
	6/1/18	DWG: 7951-7751U01