

READ ALL INSTRUCTIONS COMPLETELY AND THOROUGHLY UNDERSTAND THEM BEFORE DOING ANYTHING.
CALL CHASSISWORKS TECH SUPPORT (916) 388-0288 IF YOU NEED ASSISTANCE.

INSTALLATION GUIDE



7719

2x4" Arm Crossmember with 6" Ground Clearance Frame



Description:

2x4" A-arm crossmember with 6" ground clearance frame. Crossmember widths available from 24" to 38" in one-inch increments. Requires Chassisworks A-arm front suspension system.

Applications:

Custom car and truck installations

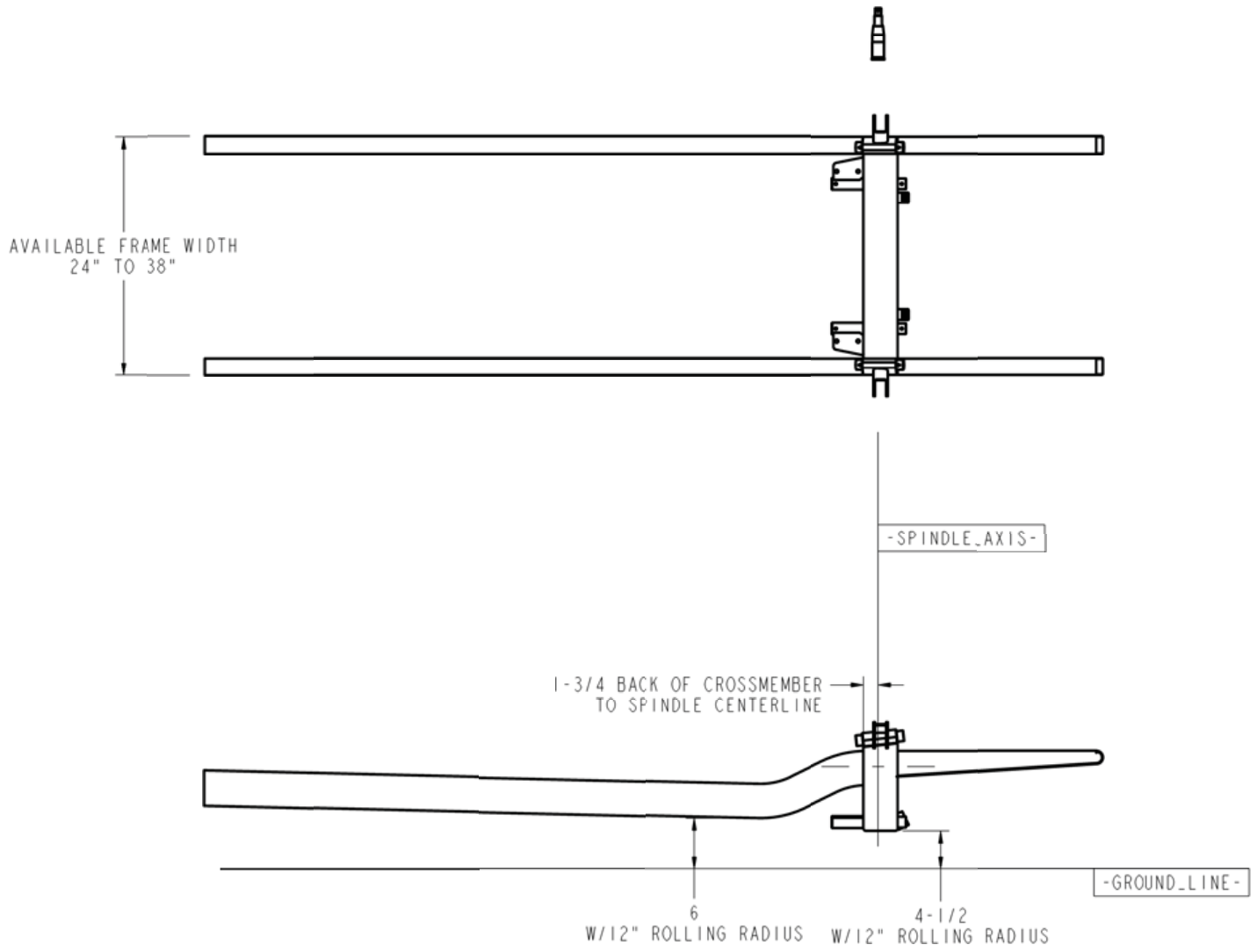

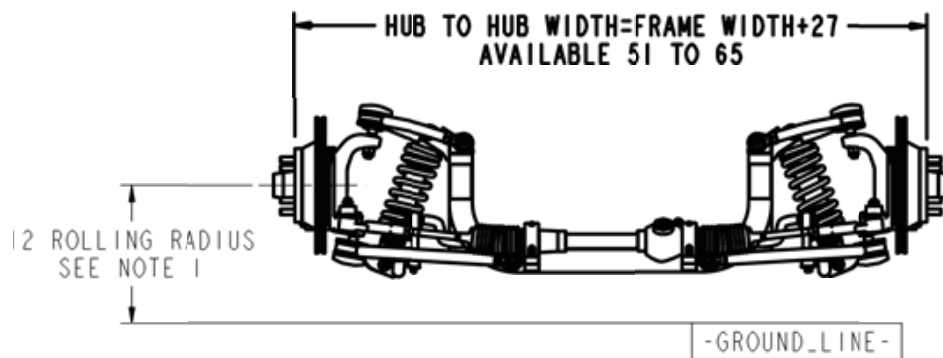
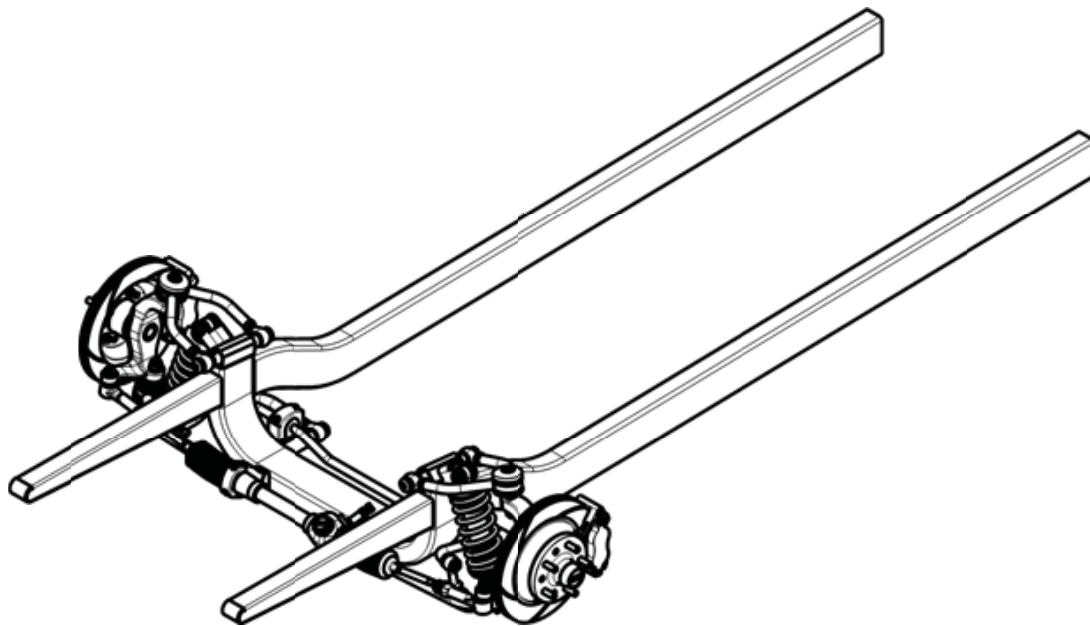

UNLESS OTHERWISE SPECIFIED		APPROVALS	DATE	DESCRIPTION	
DIMENSIONS ARE IN INCHES		DRAWN BY:	06/14/99	4 x 2 A-ARM CROSSMEMBER 6 IN GROUND CLEARANCE FRAME Chris Alston's CHASSISWORKS INC. 8661 YOUNGER CREEK DRIVE SACRAMENTO, CA 95828 (916) 388-0288 FAX 388-0295	
FRACTIONS TOLERANCES $\pm 1/16$ $\pm .5^\circ$ $\pm .1$ $\pm .05$ $\pm .05$ $\pm .005$ $\pm .005$		CHECKED BY:	10/19/99		
FINISH		DWG RELEASE LEVEL: WIP		SIZE	PART NO.
NONE				B	7719
MATERIAL				SCALE: 1:16	PART REV.
ASSEMBLY				DWG: 7171-28 REV: 1	SHEET 1 OF 1

PARTS LIST

7719 - 2x4 A-Arm Crossmember with Frame Rails

Qty	Item	Description
1 pr.	4554	Frame rails, 6" ground clearance
1	5030-XX	A-arm crossmember assembly
1 pr.	5909-BMF	Front frame horns, bumper mount style (optional)
1 pr.	5909-FHF	Front frame horns, tapered style (optional)

INSTRUCTIONS

This kit contains an A-arm crossmember for use with Chassisworks Street Machine A-arm Suspension (purchased separately). The crossmembers are available in fifteen widths from 24 to 38 inches in 1 inch increments. This will provide front hub widths of 51 through 65 inches.

Before you install the crossmember, verify that the front track width is correct for your vehicle. The front tires must clear the fenders. The front hub width is 27 inches wider than the crossmember width. Your outside tire width will be greater than the hub width. You need to measure your wheels to determine this amount.

1. With the car on a level surface block it at the ride height you want. Set the rear first and then the front. Once the frame is at ride height make sure it is level from right to left. This is an important step because once the crossmember is welded, you can only fine tune the front ride height 1/2 inch up or down.
2. After the car is at ride height, you will need a chassis centerline running the length of the car extending 20 inches forward on the spindle center line (see drawing). Use a string to make a chassis centerline on the floor. Find the center at the front of the car and at the rear, use duct tape to hold the string to the floor. You will use this later to align the new frame rails. To correctly locate the crossmember in your chassis, decide where you want the front spindle centerline. Mark the front spindle centerline on the floor. Use a second string (at least 72 inches long) to lay the spindle centerline perpendicular to the chassis centerline. Make sure the front spindle centerline string is 90 degrees to the chassis centerline.
3. We can now determine the ground clearance of the crossmember. The 4 1/2 inch ground clearance of the crossmembers are based on a 25 to 26 inch diameter tire with a mounted radius of 12 inches. If your tire has a different diameter, the crossmember ground clearance will change accordingly.
4. Block the crossmember off the floor the amount you just calculated. Position the crossmember square to the spindle centerline you have laid out on the floor. The back of the crossmember should be 1 3/4 inches behind the spindle centerline. Make sure the crossmember is level right to left, and front to rear.
5. Now you can determine the length of the 2x4 front frame rails to be installed. Measure from the backside of the crossmember to the location you want the frame rails to end. Add 1/2 inch to this dimension for the first cut. There is some additional material on the front of the frame rails. We suggest the back of the crossmember be as close to the first bend as possible. You may need to cut the front and the rear of the rail to get the best fit.

6. Trial fit the front frame rail. You will need to maintain the 6 inch ground clearance at the second bend in the rail (as shown on the drawing). Angle the front frame rail as needed to meet the rear frame you are attaching the front frame rail to. As you angle the frame rail, the front fit at the crossmember will have to be modified. The crossmember must remain level front to rear and right to left. You will be fitting the frame rail to match the crossmember. Once you have the frame rail fit, tack weld it in place. Repeat this for the second frame rail.
7. After both front frame rails are tacked in place, check all of your dimensions and the crossmember for square. When everything is checked, you can weld the rails to the crossmember and to the car.
8. If you purchased the optional front frame horns, they attach to the front side of the crossmember and create a place for you to mount the radiator, front end, and bumper. It is a good idea to use a piece of tube as a spacer at the front of the frame horns to keep them parallel. Once you have them fit, weld them to the crossmember.
9. You can now start to install the suspension package following those directions.

WARRANTY NOTICE:

There are NO WARRANTIES, either expressed or implied. Neither the seller nor manufacturer will be liable for any loss, damage or injury, direct or indirect, arising from the use or inability to determine the appropriate use of any products. Before any attempt at installation, all drawings and/or instruction sheets should be completely reviewed to determine the suitability of the product for its intended use. In this connection, the user assumes all responsibility and risk. We reserve the right to change specification without notice. Further, Chris Alston's Chassisworks, Inc., makes **NO GUARANTEE** in reference to any specific class legality of any component. **ALL PRODUCTS ARE INTENDED FOR RACING AND OFF-ROAD USE AND MAY NOT BE LEGALLY USED ON THE HIGHWAY.** The products offered for sale are true race-car components and, in all cases, require some fabrication skill. **NO PRODUCT OR SERVICE IS DESIGNED OR INTENDED TO PREVENT INJURY OR DEATH.**

Chris Alston's Chassisworks
8661 Younger Creek Drive
Sacramento, CA 95828
Phone: 916-388-0288
Technical Support: sales@cachassisworks.com

