

READ ALL INSTRUCTIONS COMPLETELY AND THOROUGHLY UNDERSTAND THEM BEFORE DOING ANYTHING.  
CALL CHASSISWORKS TECH SUPPORT (916) 388-0288 IF YOU NEED ASSISTANCE.

## INSTALLATION GUIDE



### 7701

**Bolt-On g-Machine Front Clip**  
**1967-69 Camaro/Firebird**  
**1968-72 Nova & B-O-P**



**Description:** A-arm front clip bolt-on for 1967-69 Camaro/Firebird and 1968-72 Nova & B-O-P. Includes welded front frame clip, body mounts, upper and lower A-arms, spindles, coil-over shock and springs, billet rack and pinion, billet rack and pinion mounts, ties rod ends, disc brake kit, engine mounts, and transmission mount installation instructions.

# INSTALLATION GUIDE

## 67-69 CAMAROS & FIREBIRDS; and 68-72 NOVAS & B-O-P

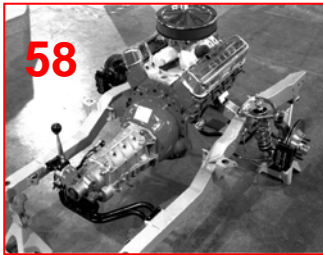
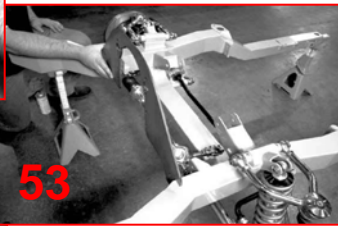
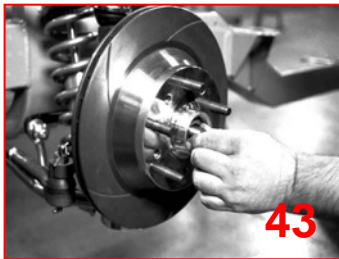
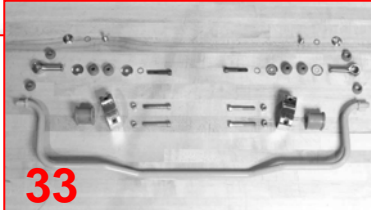
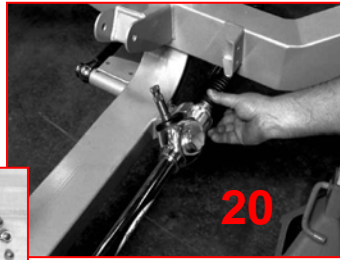
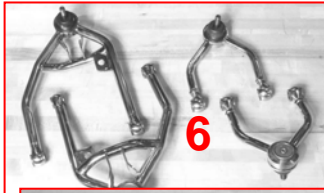

- 3** *Equipment List and Hardware List*
- 6** *Installing Lower & Upper A-arms and Spindles*
- 20** *Installing Steering Rack*
- 26** *Front Suspension Alignment*
- 33** *Installing Antiroll Bar*
- 39** *Installing Shocks and Springs*
- 43** *Installing Brakes*
- 53** *Installing Engine Mounts and Mid Plate*
- 58** *Installing Manual Transmission*
- 61** *Removing Stock Front Clip*
- 72** *Installing Bolt-On Frame*
- 78** *Installing Transmission Crossmember*
- 79** *Aligning The Frame*
- 81** *Reinstalling Factory Components*
- 84** *Installing Steering Shaft*
- 88** *Installing Fender Flaps*
- 94** *Installing Headers*
- 96** *Installing Subframe Connectors*

# CONGRATULATIONS

You have purchased the finest bolt-on Camaro front frame available. We hope you are as excited about installing it as we were about designing it.

This assembly booklet should guide you through a seamless installation. However, if you have any questions please give our tech line a call at (916) 388-0288. Monday through Friday 7:00 a.m. to 5:00 p.m., Saturday 8:00 a.m. to 1:00 p.m. PST.

Every effort has been made to insure that each component has been boxed correctly. However, we urge you to open each box and verify its contents against the enclosed parts list.

We also suggest that you read this entire assembly booklet before you begin. This will help you become familiar with the project.

Please remember that when you modify a vehicle, you assume all risks. You are changing the structural integrity manufactured into the original vehicle. As such, you need to be cognizant of potential failures. Initially you must conduct a series of short tests in a safe location. Test for handling, steering, and braking at slightly increasing speeds.

Once you are confident the vehicle handles and stops properly, take a series of drives with slightly increasing speeds stopping to check all components. Gradually increase the distance of your drives. Once you have confirmed your installation is road-worthy, you must develop a maintenance program. You must check all components for looseness, and wear and tear on a regular schedule. Your schedule must be more intense and frequent than a regular OEM vehicle.

Chris Alston's Chassisworks would appreciate any feedback regarding your experience during installation and use of this frame. If there are any accessories or options you would like to see us manufacture, please let our sales department know.

That said, let's install!

## Recommended Equipment List

This list will give you a good idea of the necessary tools required to complete this installation. There will be additional items needed.

### Hand Tools

- ◆ Adjustable wrench
- ◆ Allen wrench set
- ◆ Anti-seize compound
- ◆ Brake line wrench
- ◆ Center punch
- ◆ Clecos & pliers 1/8 size
- ◆ Combination wrenches 3/8 to 3/4"
- ◆ Vise grip pliers
- ◆ Drill bit size 1/8 (.125)
- ◆ Level
- ◆ Loctite #242 thread lock
- ◆ Philips screwdriver sizes #1 & #2
- ◆ Pry bar
- ◆ Wire brush
- ◆ Socket set 3/8 to 3/4" with 3/8 drive
- ◆ 15/16" socket with 1/2" drive ratchet
- ◆ Steel & plastic head hammers
- ◆ Straight blade screwdriver
- ◆ Pliers
- ◆ Tape measure
- ◆ Tap handle small and medium
- ◆ Tap sizes: 10-32, 3/8-16, 7/16-14, 1/2-13, 5/8-18
- ◆ Needle nose pliers

### Shop Equipment

- ◆ Floor jack
- ◆ Jack stands –quantity 4
- ◆ Digital level
- ◆ 3/8" electric drill

## Torque Specification Chart

<i>DESCRIPTION</i>	<i>TORQUE</i>	<i>DESCRIPTION</i>	<i>TORQUE</i>
A-arm pivot studs	50 lb-ft	Frame mounting bolt 5/8-11 x 3	80 lb-ft
Antiroll bar clamp socket head allens 3/8-16 x 2 1/2"	20 lb-ft	Motor mount spuds	20 lb-ft
Antiroll bar link eyebolt button head allen 3/8-16 x 3/4"	20 lb-ft	Rack clamp socket head allens 1/2-13 x 2"	45 lb-ft
Antiroll bar link eyebolt socket head allen 3/8-16 x 2 1/4"	20 lb-ft	Rack clamp caps socket head allens 5/16-18 x 1"	15 lb-ft
Balljoints	150 lb-ft	Shock spuds	20 lb-ft
Balljoint studs	105 lb-ft	Shock bolts 1/2-20 x 2 1/2"	45 lb-ft
Caliper socket head allens 3/8-16 x 1 3/8"	30 lb-ft	Tie rod stud	60 lb-ft
Frame mounting bolt 1/2-13 x 2 1/2"	45 lb-ft	Wheel studs 1/2-20 x 2 1/4" 12 point	40 lb-ft

We recommend applying a small amount of Loctite™ on all fasteners except the balljoint studs, and the tie rod studs.

## DISCLAIMER OF WARRANTY

Purchasers recognize and understand that products and services manufactured, provided, and/or sold by CHRIS ALSTON'S CHASSISWORKS, INC., are exposed to many varied conditions due to the manner in which they are used. Purchasers assume the responsibility to develop a Maintenance Procedure to identify and replace worn components before they fail. Your Maintenance Procedure must include every component on the vehicle. CHRIS ALSTON'S CHASSISWORKS, INC., makes no claims or guarantees that any product or service is designed or intended to comply with any industry standards or government regulations. CHRIS ALSTON'S CHASSISWORKS, INC., makes no claims or guarantees in reference to any acceptance for use of its products or services by any entity or racing association, or that its products can legally be installed on any vehicle that operates on a public highway.

CHRIS ALSTON'S CHASSISWORKS, INC., reserves the right to make changes or improvements in design, materials or specifications or make product changes without incurring any obligation to replace, change or improve products manufactured prior hereto.

There are NO WARRANTIES, either expressed or implied. There is no warranty of merchantability. Neither the seller nor manufacturer will be liable for ANY loss, damage or injury direct or indirect, arising from the use or inability to determine the appropriate use of any product. Buyer will not rely on CHASSISWORKS skill or judgment to select or furnish the proper part or equipment for their application. Buyer expressly affirms that they are relying upon their own skill and judgment to select and purchase suitable goods.

Before any attempt at installation, all drawings and/or instruction sheets must be completely reviewed to determine the suitability of the product for its intended use and that the buyer has the skills required to install and maintain the product. Buyer assumes all responsibility and risk for correct installation. CHRIS ALSTON'S CHASSISWORKS, INC., accepts no responsibility for failure to read, or understand the installation guidelines. All products are intended for racing or off-road use and may not be legal for highway use. The information contained in this *Installation Guide* is correct to the best of our know-ledge and belief, having been compiled from reliable sources. However, CHRIS ALSTON'S CHASSISWORKS, INC., cannot assume responsibility for possible error. BUYER IS RESPONSIBLE FOR DETERMINING THE SUITABILITY OF ANY AND ALL PRODUCTS PURCHASED FROM CHRIS ALSTON'S CHASSISWORKS, INC.

It is expressly understood and agreed between purchasers and Chris Alston's Chassisworks, Inc., that as part of the bargain between CHRIS ALSTON'S CHASSISWORKS, INC., and purchasers, and in consideration of doing business with each other, all purchasers take, select and purchase said racing parts, equipment any and all inventory, or services from CHRIS ALSTON'S CHASSISWORKS, INC., "as is" and "with all faults" and CHRIS ALSTON'S CHASSISWORKS, INC., shall always provide purchasers with a full and complete opportunity to examine, at purchasers' leisure and convenience, any racing parts and equipment, any and all inventory, or services when purchasing or contemplating purchasing from CHRIS ALSTON'S CHASSISWORKS, INC. Use of CHRIS ALSTON'S CHASSISWORKS, INC., products constitutes acceptance of this agreement in its entirety.

**BUYER IS RESPONSIBLE FOR DETERMINING THE SUITABILITY OF ANY AND ALL PRODUCTS PURCHASED FROM CHRIS ALSTON'S CHASSISWORKS, INC. NO PART, COMPONENT, INVENTORY, OR SERVICE MANUFACTURED OR SOLD BY CHRIS ALSTON'S CHASSISWORKS, INC., IS DESIGNED OR INTENDED TO PREVENT INJURY OR DEATH.**

Purchasers understand and agree that no officer, director, employee, salesperson, or agent of CHRIS ALSTON'S CHASSISWORKS, INC., has any authority to make any statement contrary to the terms of this agreement. CHRIS ALSTON'S CHASSISWORKS, INC., disavows any statement contrary to what is herein above written.

# Frame and Sheet Metal Hardware List

## #3097 HARDWARE BOX FOR CAMARO/NOVA BOLT-ON FRAME

<i>QTY</i>	<i>PART</i>	<i>DESCRIPTION</i>	<i>WHERE USED</i>
8	2052	Shim, Camaro clip body mount 2.5x.63x.10	Between floor and body bushings.
2	1248	Alignment pin 67-69 Camaro	Aligns front clip.
3	3430	Button head allen 5/16-18 x 3/4"	Caps clutch pivot holes in frame.
6	3454	Cup point set screw 1/2-13 x 1/2"	Caps extra holes in frame horns.

## ***Installing Suspension***

In this section you will install all of the front suspension components and align the front-end geometry. It is easier to do this before the new front clip is installed to the body.

If you purchased plain steel A-arms, have them painted or powder coated before you assemble them. Do not get paint in the balljoint housing thread bore or in the pivot bushing bores. The balljoint bores are precision machined. Consequently, you cannot install and remove the balljoints multiple times. The self-locking threads on the balljoint will destroy the balljoint housing if it is removed and installed several times. Have your A-arms painted before the balljoint is assembled to minimize this potential problem.

Do not plate or chrome the A-arms. The plating solution can leak into the tubes and cause them to rust from the inside out. If you drill drain holes in the tubes, the A-arm will crack from the holes. If you want a highly polished look, purchase our stainless A-arms.

The mild steel lower A-arms are shipped without their pivot bushings installed to make painting or powder coating easier. Use an arbor press to install the bushings.

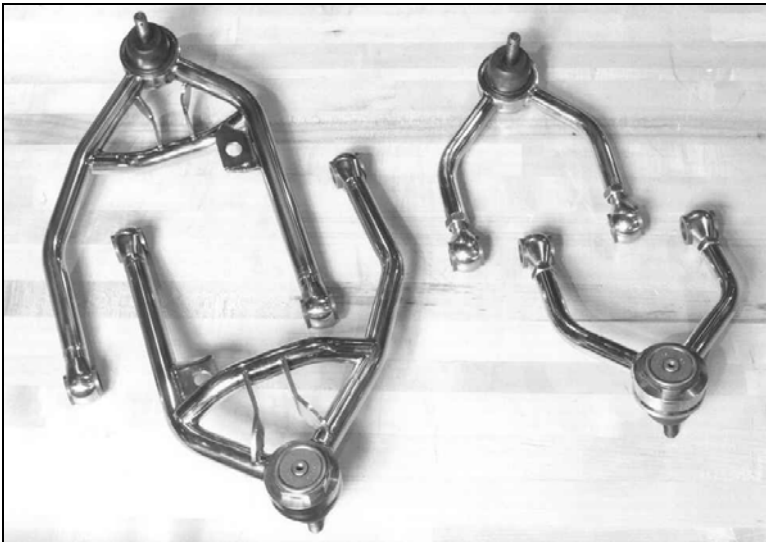

## ***Installing Upper & Lower A-arms and Spindles***

The first parts installed will be the upper and lower A-arms. The stainless steel lower A-arm comes with all of the bushings installed. You will be installing the bushings and rod ends in the upper A-arms later.



For identification, the driver side A-arm assembly is embossed with a "D" on the balljoint housing.

The passenger side is embossed with a "P" on the balljoint housing.



The balljoint rubber boot is installed in the balljoint housing first. Because the boot fits tight in the housing, installing it before the balljoint is easier. Drop the boot into the machined bore in the balljoint housing.

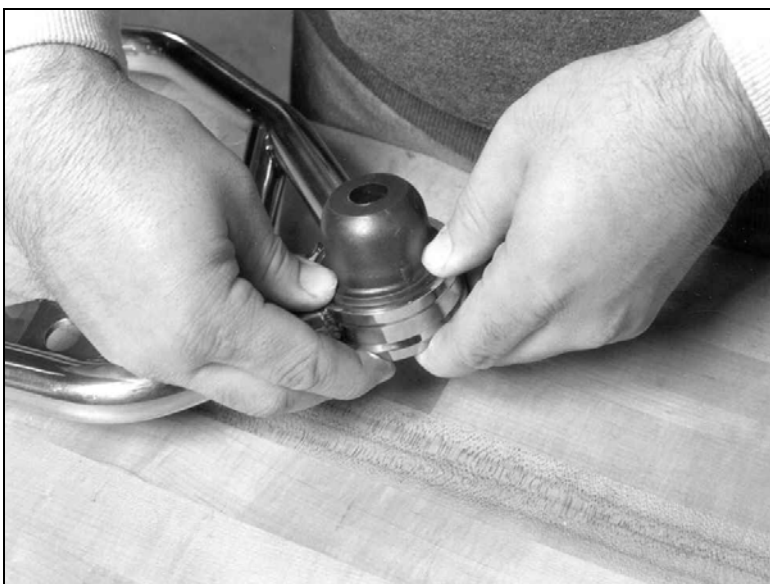

Work your way around the boot's edge, pushing it down into the bore with your fingers. You can also use a blunt tool to do this.



During the assembly process we are going to coat all of the threaded assemblies with an anti-seize compound to prevent the threads from being damaged and aid disassembly in the future.

Put a thin layer of anti-seize on the balljoint threads.



The balljoint is then screwed into the balljoint housing as far as possible by hand. Make absolutely sure that the thread starts straight. This is a little tricky. The threads on the balljoint are easy to cross thread.



Use the balljoint wrench included with your kit to tighten the balljoint. Tighten it until it is fully seated against the balljoint housing. The force required can be over 150 lb-ft of torque. Be careful not to scratch the A-arm. Repeat this for the passenger side lower A-arm.

One convenient method for holding the A-arm while installing the balljoint is to temporarily install the A-arm on the frame.

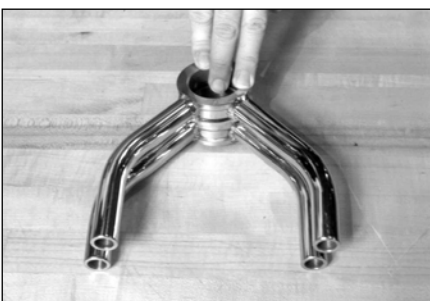

The upper A-arms will be assembled next. Although they are very similar, they are not identical. The letter "D" or "P" on the balljoint housing identifies which side of the car the A-arm installs in.



Use a 5/8-18 tap to chase the threads in the upper A-arm. Clear any debris left in the threads.



Use the same procedure to assemble the upper A-arm as the lower. First, install the balljoint boot into the balljoint housing.



Next, apply a layer of anti-seize to the balljoint threads.



Thread the balljoint in as far as possible by hand.



Finish tightening the balljoint with the balljoint wrench until it is seated tight against the balljoint housing. Repeat this for the passenger side upper A-arm.



Install the rod ends into the upper A-arms. To provide an initial alignment baseline, the jam nut should be threaded until there is 1-1/16 inches of thread remaining past the jam nut.



After the application of another dab of anti-seize, the rod ends are threaded into the A-arms, until the jam nuts are snug against the arm itself.



This step must be done carefully because the upper and lower A-arm mounts are threaded and welded to the frame. Use the 5/8-18 tap to chase the threads on the front and backsides of both upper mounts. Blow any remaining particles out of the hole with an air hose.

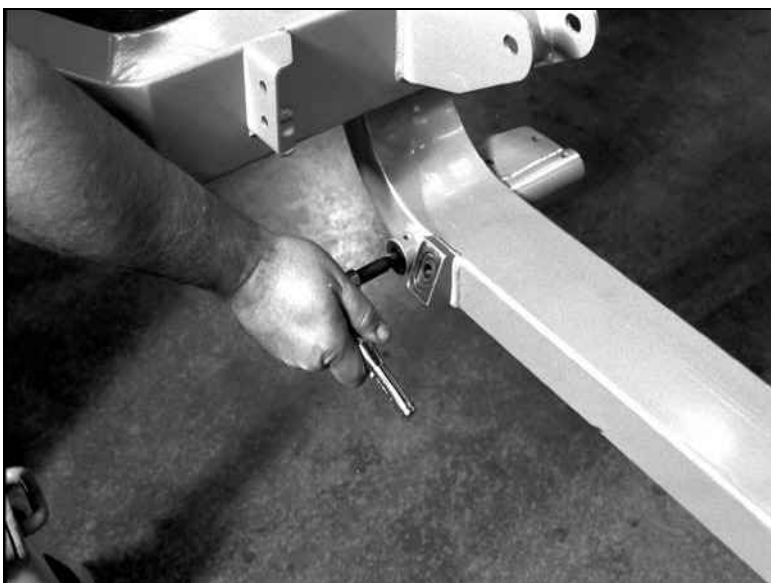

Next, chase the threads in the lower A-arm mounts with the 5/8-18 tap and blowout any remaining particles.

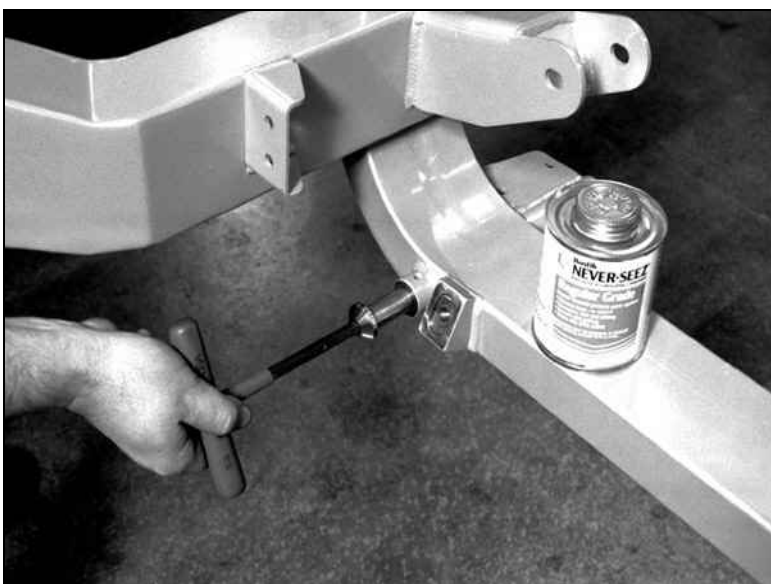

Now, apply some anti-seize to the threads of the pivot stud. Also put anti-seize inside the bore of the A-arm mounts. Insert one of the lower A-arm pivot studs and then run it in all the way to its stop, it should go in easy. Use the same procedure to verify all of the pivot studs will easily thread into their mounting locations.

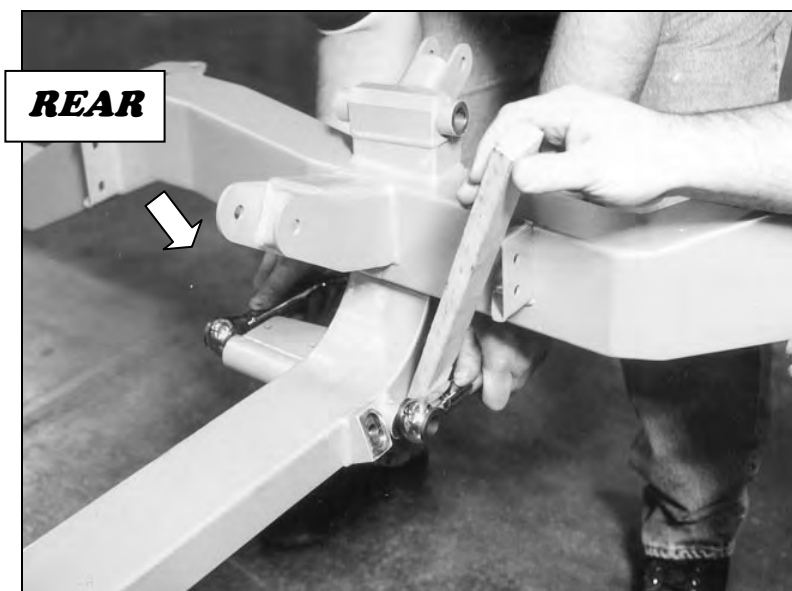

The lower A-arm fits tight over the mount. Slide the rear of the A-arm onto the mount and then use a piece of wood between the frame and the A-arm to pry it over the mount. A 12" piece of 1x2 works well.

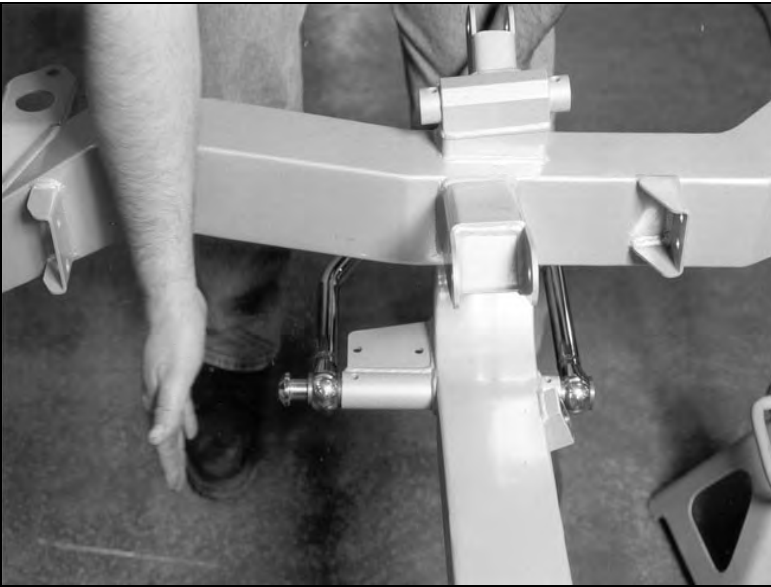

When installing the lower A-arm pivot studs, be careful not to damage the threads. Tap the pivot stud into place with your hand.



If the hand method does not work, you can use a plastic-tipped hammer to gently install the pivot stud. It is best to move the pivot stud a small amount at a time until the threads make contact.

Do not put grease on the pivot bushings they are self-lubricating.

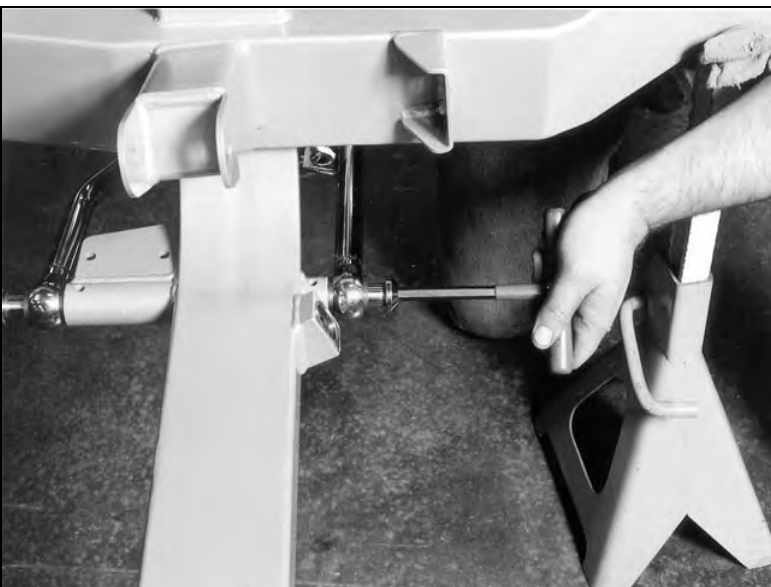

Once the pivot studs are in place, use an Allen T-wrench to tighten them. The pivot studs should go in easily and should be tightened until they are fully seated. This will give the bushings the proper amount of crush, and allow the lower A-arm to move with a small amount of resistance.

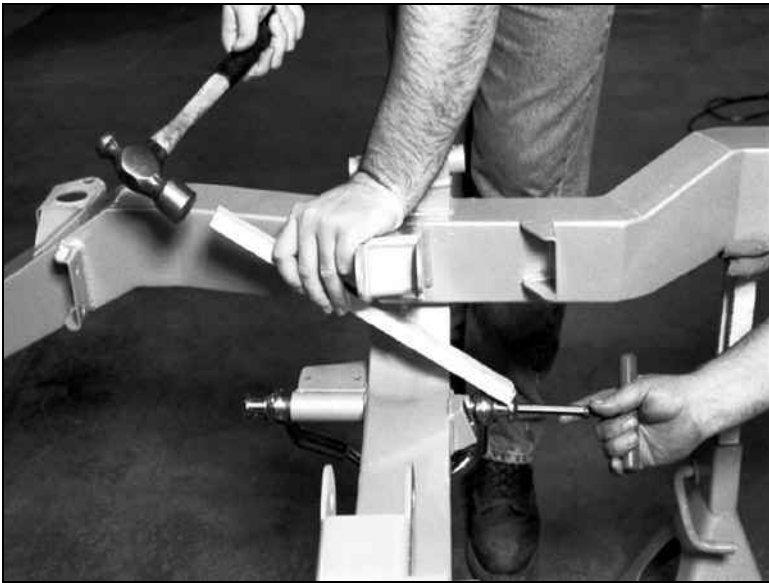

If you have to remove the lower A-arm pivot studs, use a piece of wood and a few taps with a hammer while turning the pivot stud counter-clockwise. The pivot stud will come out easily.

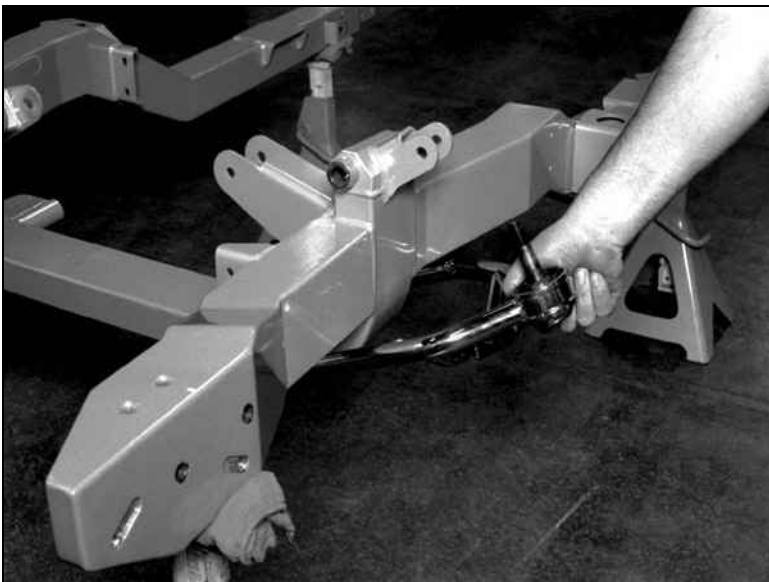

After tightening the lower A-arm pivot studs, check to be sure the A-arm swings freely but snugly throughout its travel.

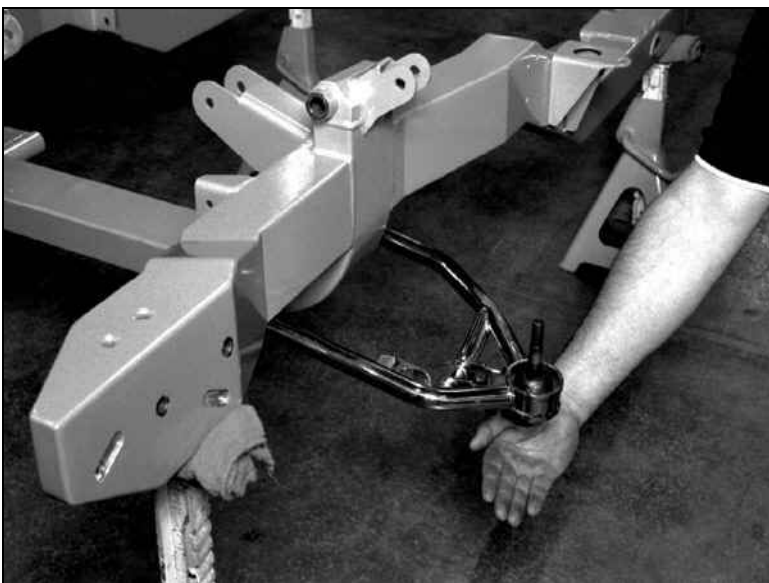

The lower A-arm should also stay suspended when released. It should take a few pounds of pressure to make it move.



A set screw is used to lock the A-arm pivot studs. The set screw locks on the groove machined into the pivot stud.



Before installing the pivot stud set screws, apply a drop of Loctite™ thread sealing compound to the screws. Be careful not to get excess Loctite™ in the pivot stud bore.

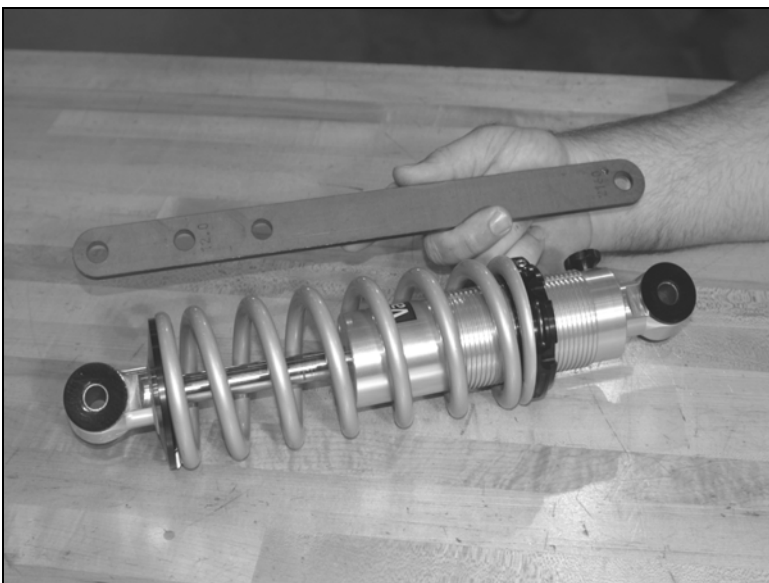

The next step is to install the upper A-arm and spindle. During this step you are going to need the lower A-arm at its ride height position.

Two of these shock simulators are included in the suspension kit. The top hole represents full shock extension, the bottom hole full compression, and the middle hole (at 12 inches) represents the ride height of the shock absorber.

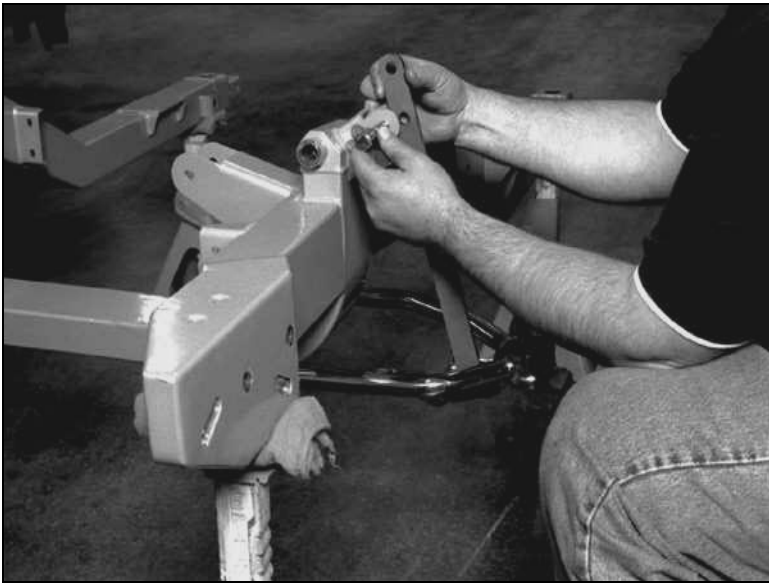

Next, install the shock simulator at the ride height position. Install the lower bolt first and then the upper.

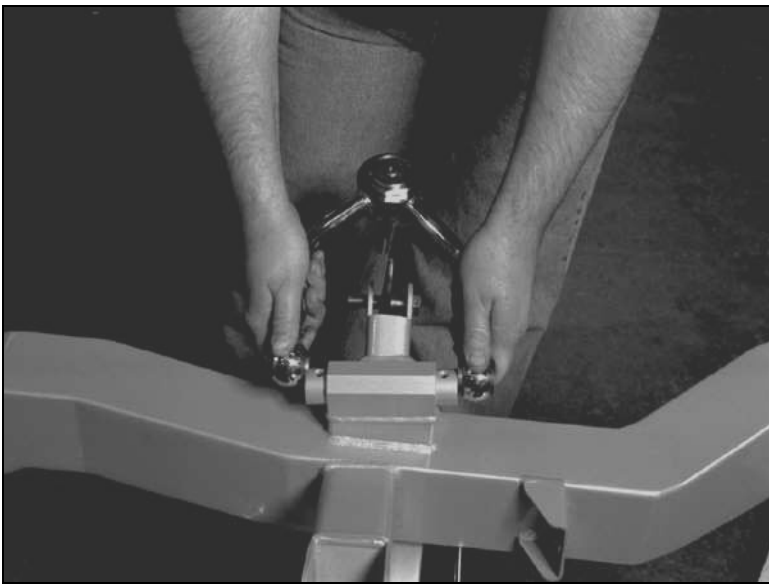

Installing the upper A-arm is similar to installing the lower A-arm. Slide the front rod end over the front mount first and then swivel the rear one into place.



Install the upper mount bolts just like the lower mount bolts. Do not fully tighten them because they need to be moved when we adjust the front suspension settings later. Repeat the installation of the upper A-arm on the passenger side.



You are now going to install the dropped spindles. The "L" cast into the back of the spindles, does not designate "Left," it is the foundry mark. The best way to identify the driver and passenger side spindle is to remember the steering arm (shown with arrow) always goes toward the front of the car.

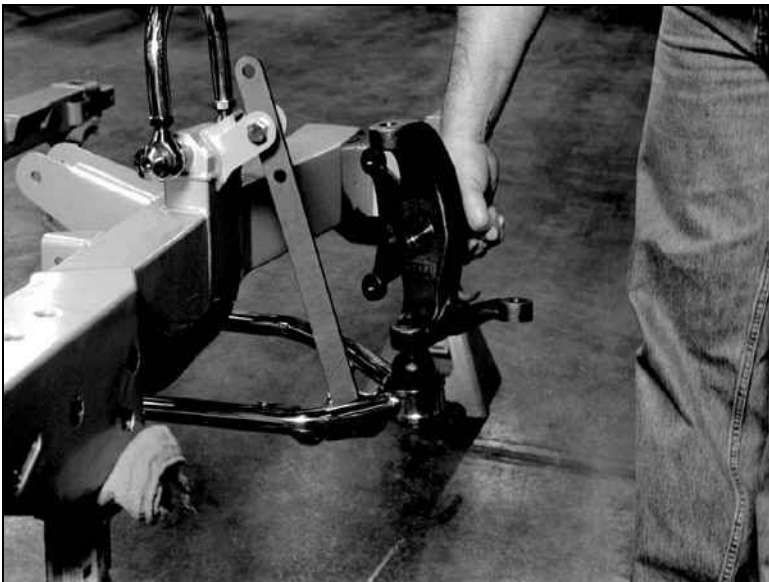

Place the driver side spindle over the balljoint and thread the 9/16-18 castle nut on.



The balljoint castle nut will not thread on easily if the threads are nicked. A thread file can be used to correct the problem. After filing, try the castle nut again before putting the spindle on. Thread files can be found at most auto parts stores.

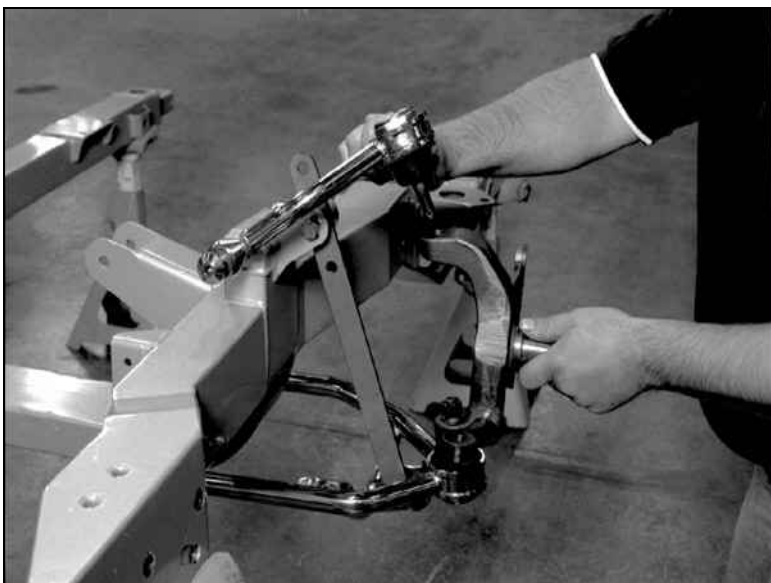

Place the spindle over the lower balljoint and install the washer and castle nut. The upper A-arm is then lowered into position and secured to the spindle with another washer and castle nut.

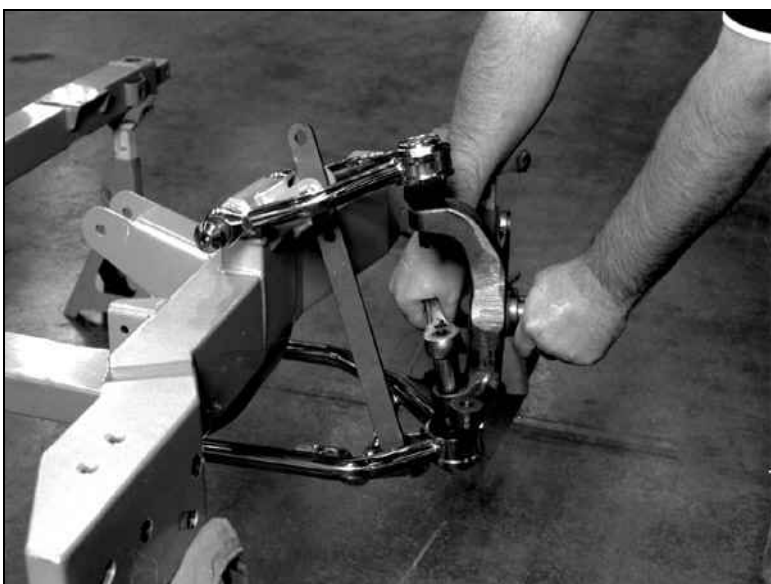

Tightened both upper and lower balljoint castle nuts.



Insert the cotter pin through the hole in the balljoint. You may need to tighten it a small amount until the slots in the castle nut align with the hole.



With the cotter pin installed, use pliers to fold the legs over the castle nut. One leg goes down the other over the top of the balljoint stud.

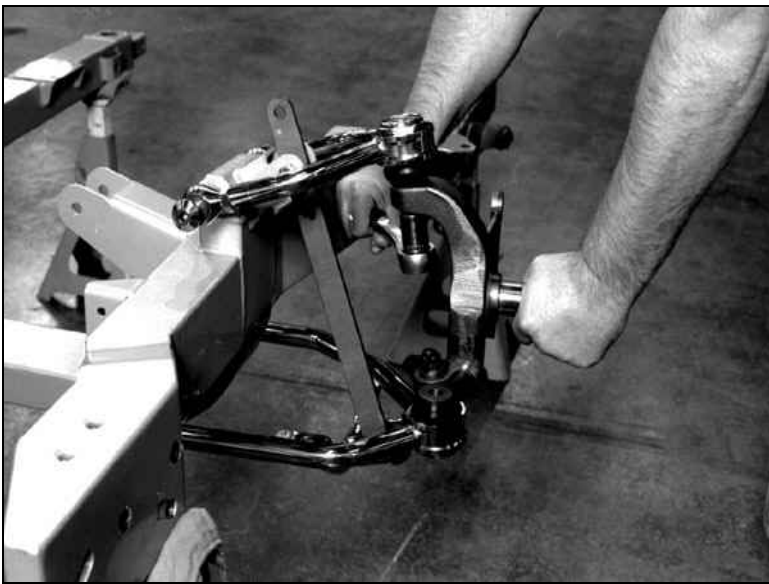

Repeat the procedure for the upper A-arm. First tightening the castle nut.



Install the cotter pin and fold the legs over as we did on the lower one. Repeat this procedure on the passenger side of the car.

## ***Installing Steering Rack***



Mounting the steering rack is next. Chase the threads in the rack-mounting bosses with a 1/2-13 tap before mounting the billet mounts.

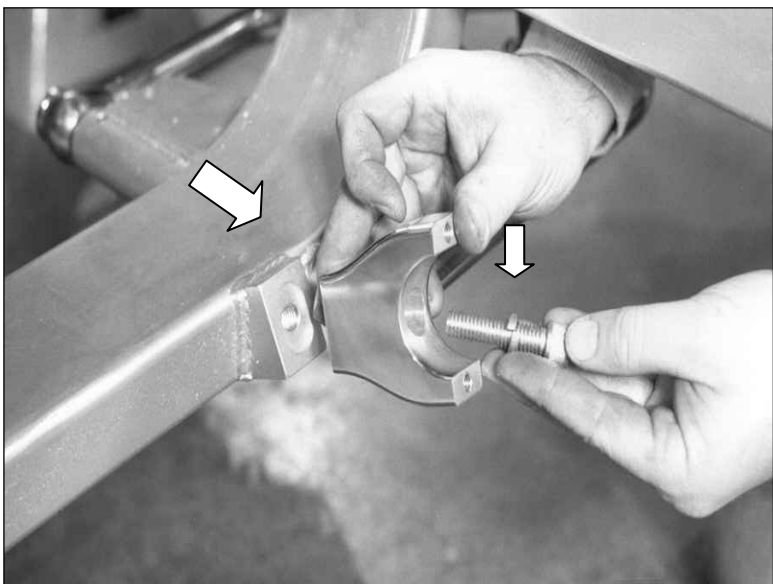

The rack-mounting bosses are factory welded to the frame. Use the 1/2-13 x 2" socket head allen and custom 1/2" lock washer to mount the lower half of the billet rack clamp to the mounting boss. Use a small amount of Loctite™ on the socket head allen.

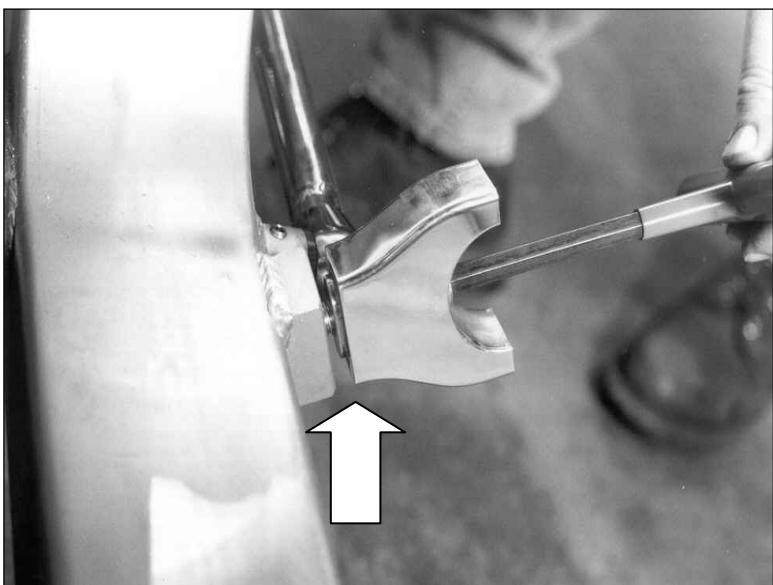

The raised section on the back of the billet clamp matches the milled recess on the mount bosses.



Now repeat the procedure for the other billet rack mount.

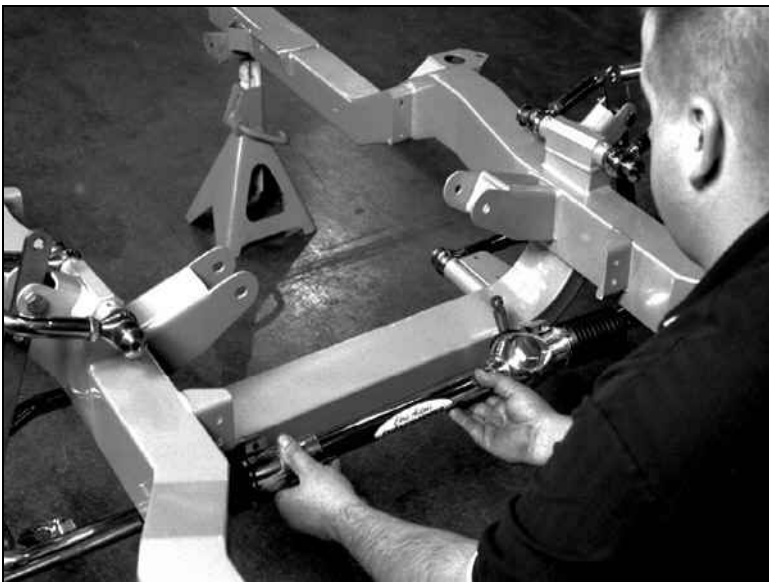

With the lower half of both rack mounts installed on the crossmember, the rack itself is set into position.



One of the exclusive design features of our rack and mount is the ability to rotate the rack to provide any desired angle from the steering column to the rack input shaft. Here the shaft is laid almost against the crossmember.

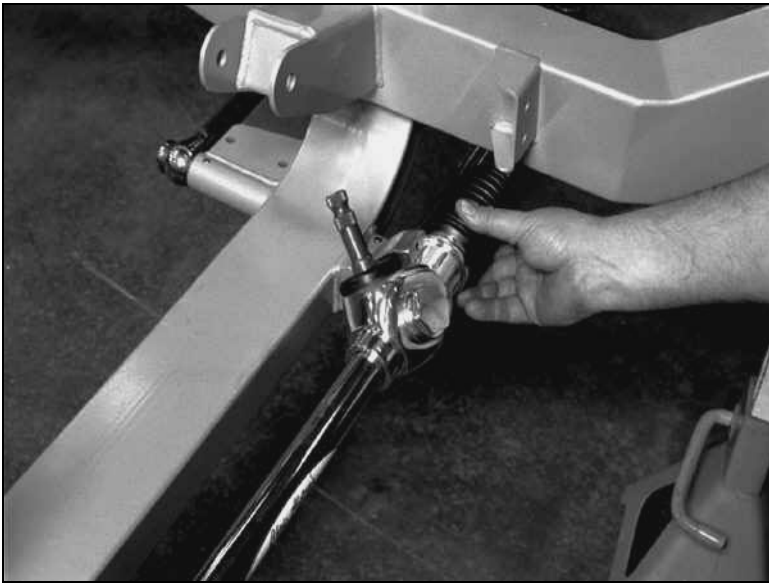

If additional clearance is needed between the pinion and the cross-member, you can raise the pinion up higher. A lower angle will be used to clear the side motor mount bracket. Rotate the rack to minimize the u-joint angle.



Push the rack firmly into each mount. Secure the rack by installing the billet rack clamp caps. Use the provided 5/16-18 x 1" stainless steel socket head allen and custom lock washer. Use a small amount of Loctite™ on the socket head allen.



Tighten the cap with your T-Handle Allen wrench. Once you have the cap tight, the next step will be aligning the front end.



The first step in aligning the new A-arm front suspension is to center the rack in its travel. Placing a U-joint on the rack makes turning it easy.



Turn the rack toward the passenger side of the car until it stops (full lock position).

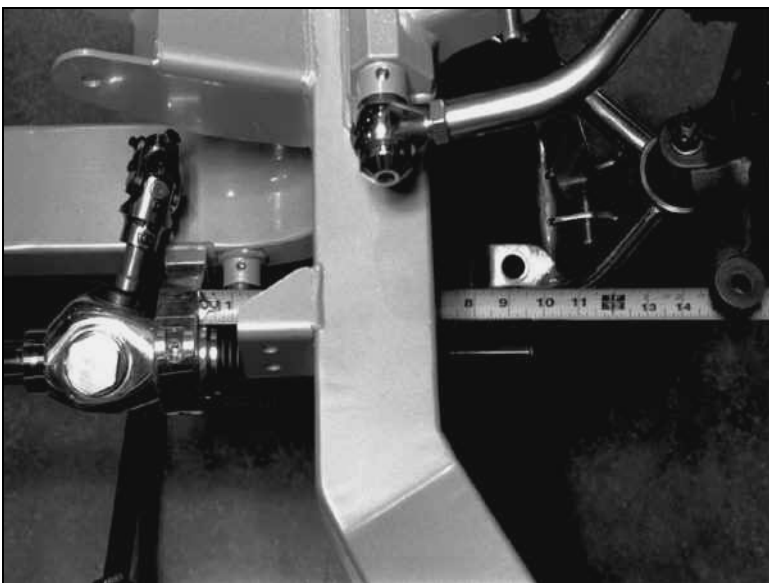

On the driver side, measure and record the distance from the rack mount to the end of the tie rod end. In our example the length is 9 7/8 inches.

Next, turn the rack all the way to the driver side and record the measurement from the rack clamp to the end of the tie rod. In our example the length is 15-1/8 inches.

To calculate how far back to move the rack to center it, use this formula: add the two lengths together and divide by two. This is the distance from the rack clamp on the driver side to the end of the tie rod with the rack centered.

Example: Driver side length equals 15-1/8"  
Passenger side length equals 9-7/8"

15-1/8" plus 9-7/8" equals 25" divided by 2 equals 12-1/2".

Turn the rack back toward the passenger side until the length is 12-1/2 inches. Check your rack; do not assume our dimension is correct for your rack.

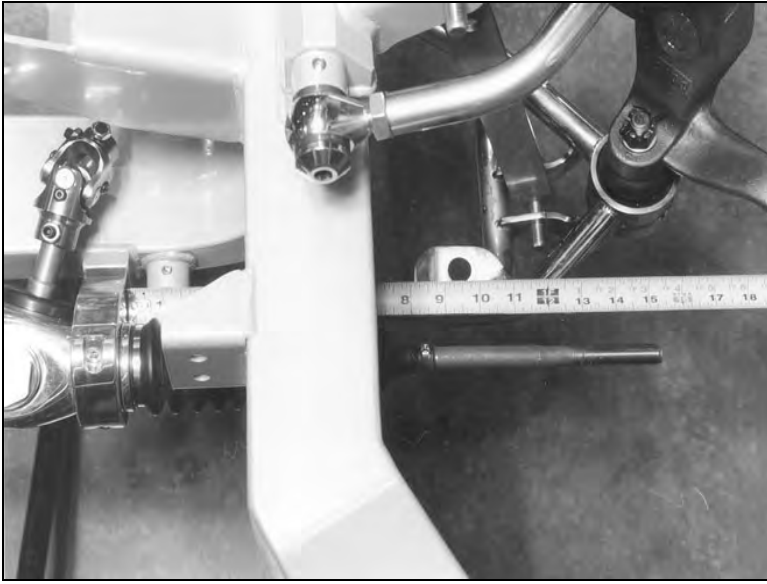

With the rack & pinion centered, you can set the spindle alignment. Measure from the outside of the frame to the inner edge of the tie rod hole in the steering arm. Set this dimension to 8 5/8 inches. This will make the spindle straight forward while you adjust the tie rod length.

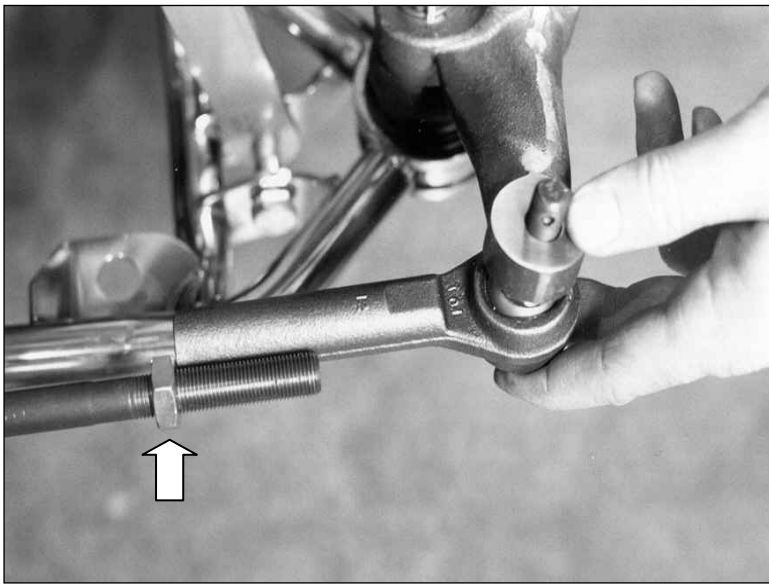

Install the tie rod end in the steering arm. Hold it in place next to the tie rod and adjust the jam nut until it is against the tie rod end.



Remove the tie rod end from the steering arm and thread it onto the tie rod until it contacts the jam nut. Next, reinstall the tie rod end into the steering arm. Verify the distance from the frame to the inside of the tie rod end; this should be 8 5/8 inches as measured earlier.

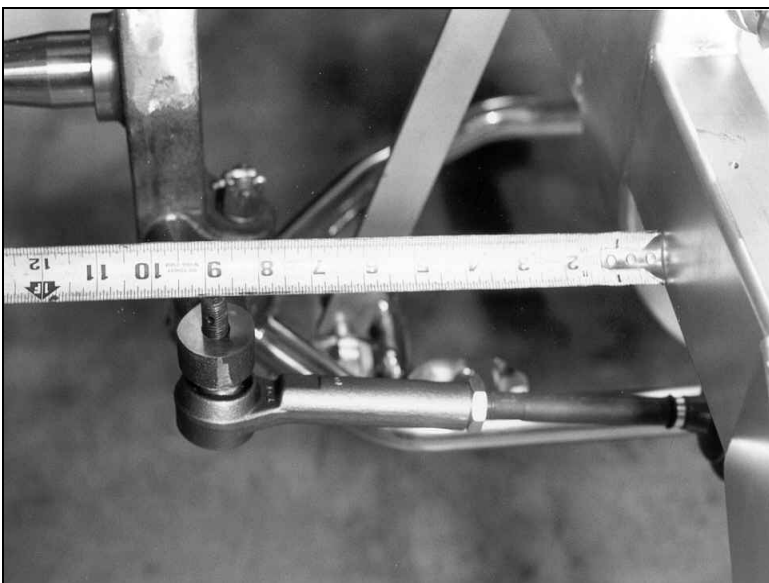

Repeat this procedure for the passenger side. The measurements are the same as the driver side.

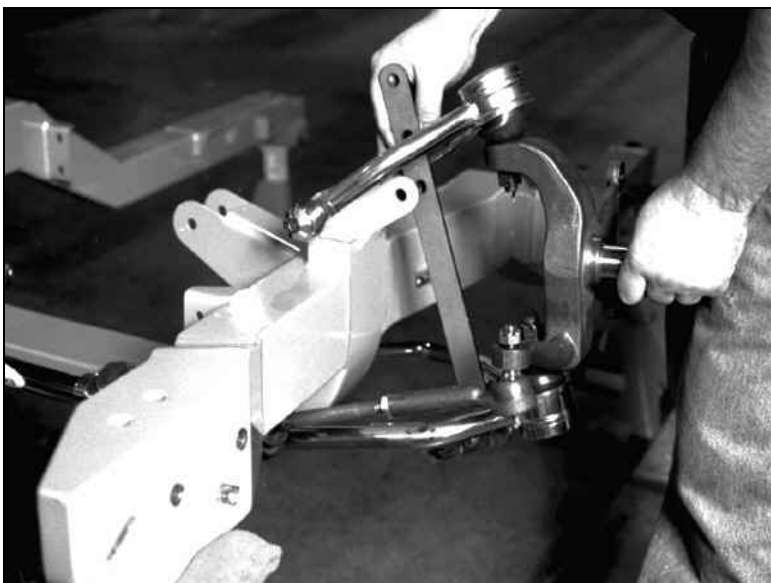

Loosely install the castle nut on the tie rod end. Make sure the spindle moves smoothly from full shock extension to full compression, as indicated by the holes in the shock simulator.

Now, set the shock simulator in the ride height position before you start to check the suspension settings. Do this on the driver and passenger sides.



### ***Front Suspension Alignment***

Before checking the front-end alignment, check to be sure the frame is still level. Put a level on the frame as shown, and adjust the jack stands until the car is level front to rear.

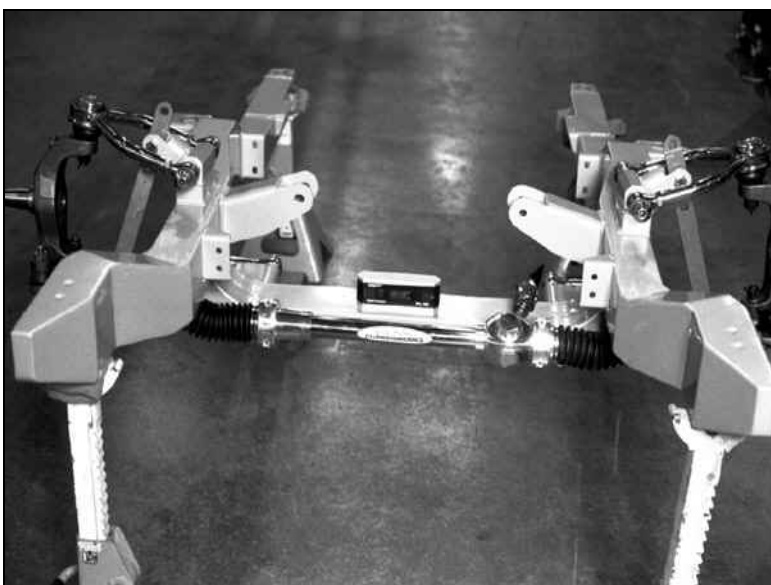

Readout from a digital level is preferred for accuracy when setting the front-end alignment. Level the crossmember and if needed, adjust the height by placing shims under one of the jack stands.



First, check and record the camber and caster readings, they will be adjusted later.

The caliper-mounting bosses are machined perpendicular to the spindle so they are an excellent place for the level.

To check the camber, hold the level against the machined caliper mounting pads on the spindle. Record the reading.

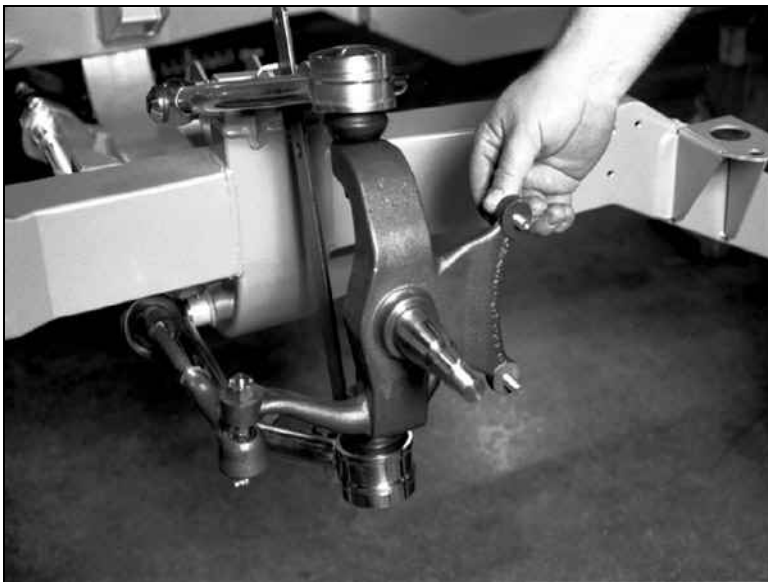

Next, check the caster by installing the 3/8-16 x 1 3/8" caliper mounting socket head allens (supplied in your brake kit) into the threaded bosses on the spindle.



Set the digital level against the caliper mounting bolts. Record the caster reading. Positive caster is when the spindle top is tipped toward the rear of the car when viewed from the side.

We will now fine tune the camber and caster settings.

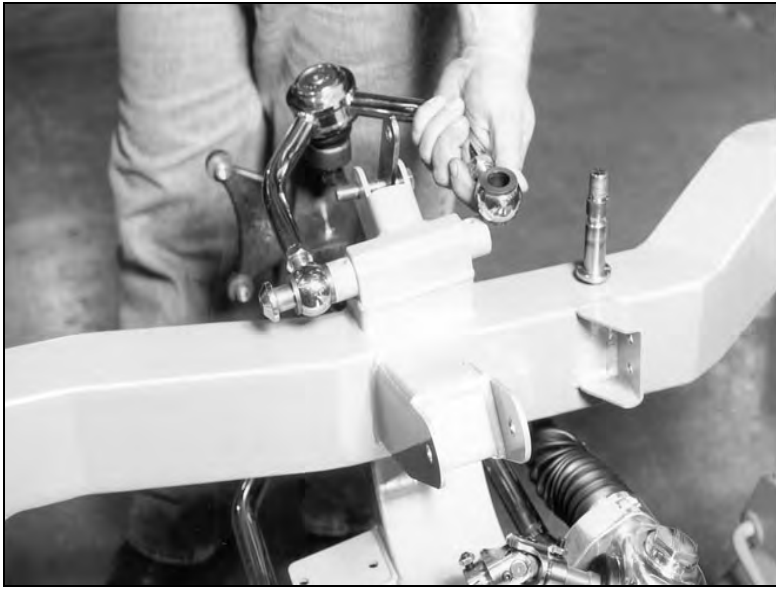

The adjustment for both caster and camber is made through the adjustable rod ends on the upper A-arms. Moving both rod ends out increases positive camber.

To adjust caster, move the forward rod end out further than the rear. This increases positive caster.

Adjust the upper A-arm rod ends until you have the camber set at zero, or 90 degrees on the digital level and the caster set at 1 to 5 degrees positive. Both sides must be the same. Remember, if your car has a forward rake when sitting on the ground the positive caster will be decreased by the angle of the bodies rake. Three degrees of positive caster with the body level will only be 1 degree of positive caster with a 2 degree body rake. Adjust one rod end at a time one-half turn until you have the correct setting. Repeat for the passenger side before going to the next step.



The next step is setting the toe-in. Cut two pieces of 3/4 inch tubing or electrical conduit, 26 inches long. Drill a 3/8-inch hole through each tube 9 inches from one end. These tubes will assist in setting the toe-in.



Bolt the tube to the upper caliper-mounting boss with the long end to the front of the car. The 26-inch length simulates the tire diameter and drilling the hole 9 inches from the end centers the bar over the spindle.

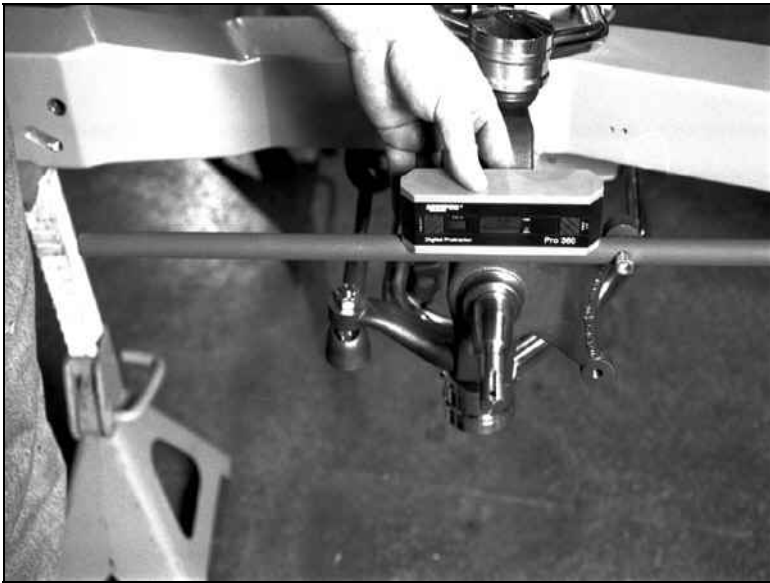

Next, set the bar level and tighten it down. Do this on both the driver and passenger sides.



Using two tape measures, measure the outside width at the front and the rear of the tubes. The front dimension should be  $\frac{1}{8}$  to  $\frac{3}{16}$  less than the rear; this is the total amount of toe-in. Record the front and rear dimensions and calculate the amount of toe-in by subtracting the front measurement from the rear.



To adjust the toe-in, rotate the tie rod ends to move the spindle in or out as required. Make sure to rotate both the driver and passenger side the same amount. One-half revolution of both tie rod ends will change the toe-in by approximately  $\frac{1}{4}$  inch, front to back.



If rotating the tie rod end 360 degrees changes the toe-in too much, use the rack tie rod to make smaller adjustments. Put the tie rod end in the steering arm and snug the castle nut before adjusting. Use vise-grips to grab onto the tie rod and rotate it to adjust the length. Be careful to turn both tie rods the same amount.

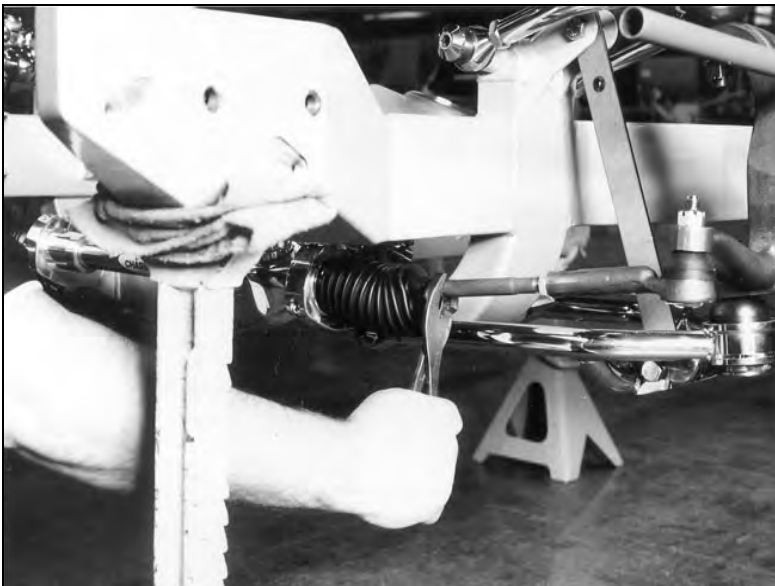

When turning the tie rods, the rubber boot will “wind up” on the tie rod. Once the toe-in is adjusted, use pliers to “unwind” the boot around the tie rod. Gently grab onto the outer boot clamp and twist it back around until the boots are straight. The jam nuts can now be tightened against the tie rod ends.

Verify caster, camber and toe-in are correct before proceeding.

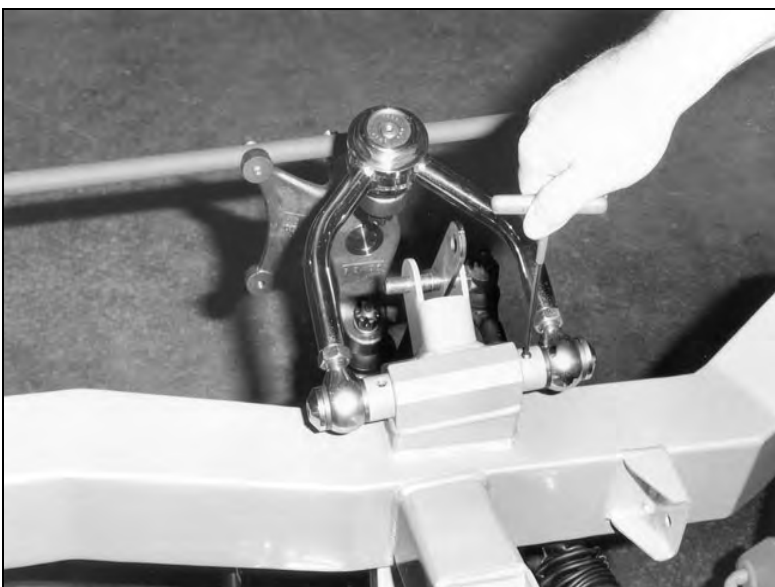

Once the camber, caster, and toe-in are set, tighten down the A-arm bolts and jam nuts, and install the set screws with a drop of Loctite™.



Next, you can final assemble the tie rod ends. Start by installing the grease zerk fitting in the hole at the bottom.



Install the rubber boot.



Put the tie rod ends back into the steering arm. Tighten the castle nut and, install and bend the cotter pin like you did on the balljoints.

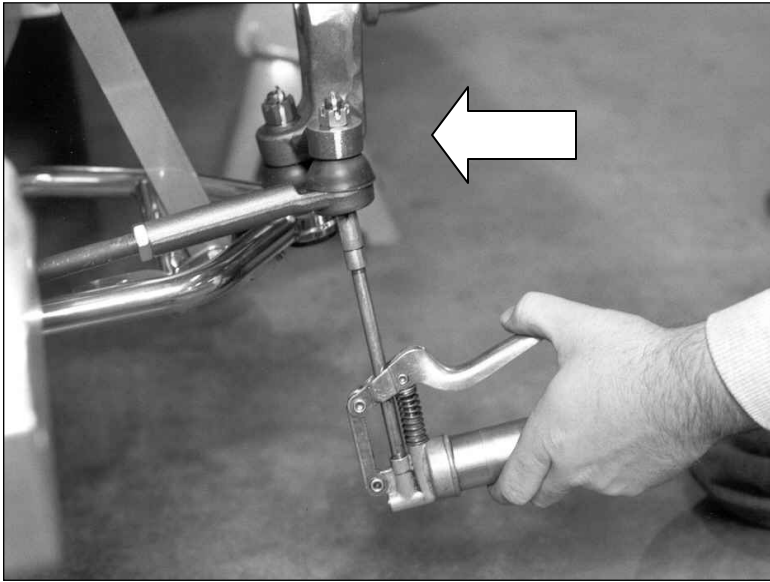

Grease the tie rod end with a small grease gun. Add only enough grease until a small amount starts to come out from under the rubber boot.



Grease the upper and lower balljoints. Install the zerk fittings and inject grease with a grease gun. Put only enough grease in to make the balljoint rubber boot bulge out on the side. If you are installing the balljoint caps, remove the zerk fitting.



Set the stainless steel cap over the balljoint.



The caps are held in place with the countersunk stainless steel allen screws provided. They screw into the hole where the grease zerk was just removed. Be sure to remove all grease from the threads in the balljoint and Loctite™ the countersunk allen head screw in place.

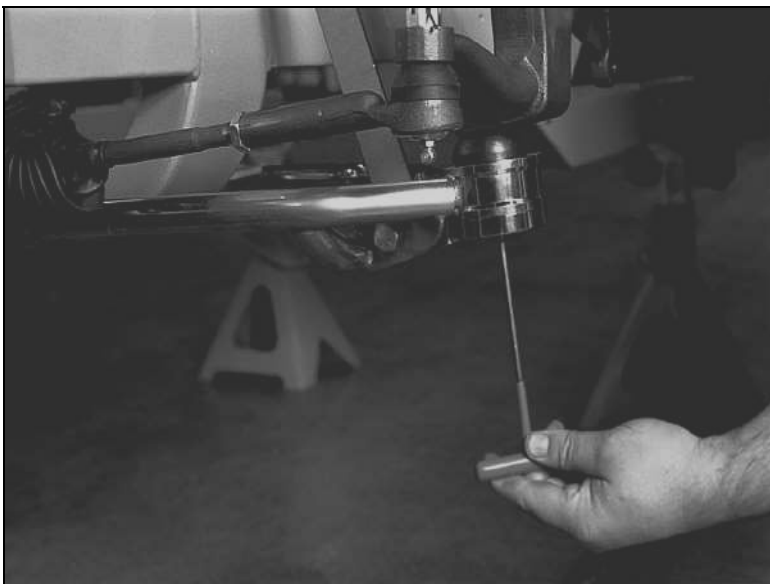

Use the same procedure to install the lower balljoint caps.

***Installing Antiroll Bar***

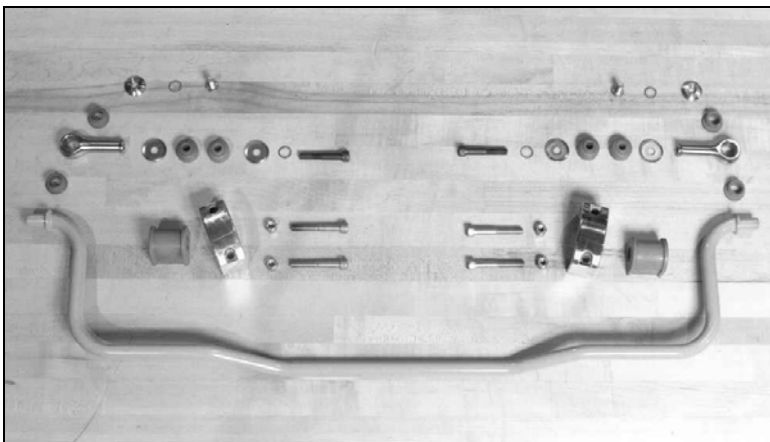

Next, install the antiroll bar.

These are the components of the antiroll bar kit.



To prevent the urethane bushings from squeaking in action, use the supplied silicone grease to coat all sides of the urethane bushing that contact a metal surface. A thin screwdriver can be used to smear it around inside the bushing. Take extra care not to get this grease all over, it's very sticky.



To open up the bushings, use the handle end of the balljoint wrench that is included in the suspension kit.



Once the slot in the bushing is opened, slide it over the antiroll bar near the 90-degree bend.



With both bushings on the bar, bring it up from under the car and set it in position.

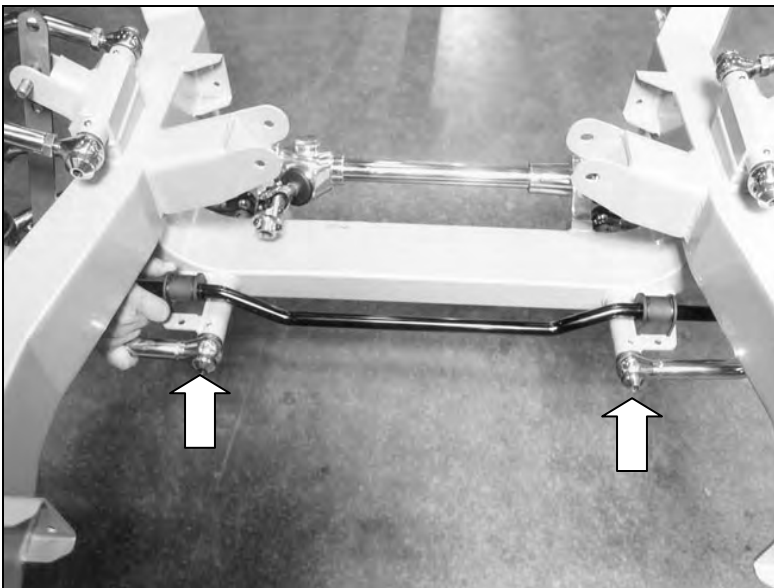

Center the bushings on the mounting pads welded to your frame.



Center the antiroll bar in the frame by measuring from the side of the frame to the end of the bar on the driver and passenger sides.



Slide the billet aluminum cap over the bushing and secure with the 3/8-16 x 2 1/2" socket head allen and locknuts provided.



Put the urethane bushings into the upper antiroll-bar-link eyebolt.

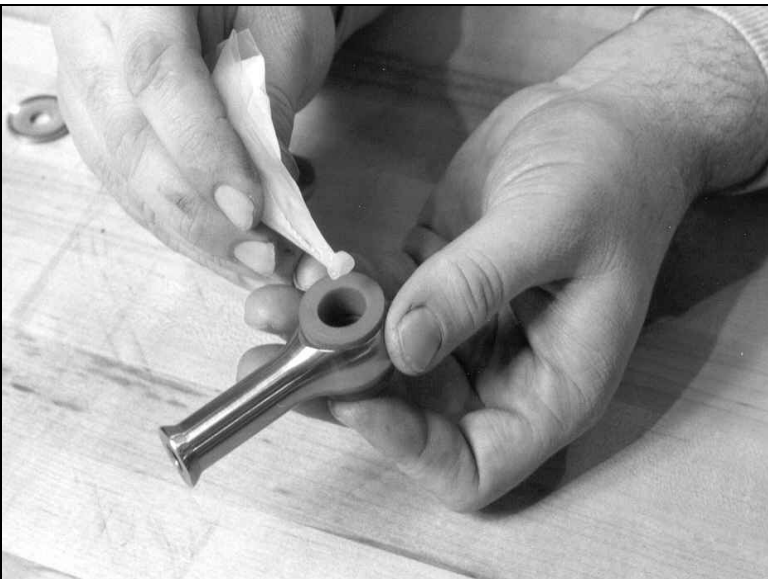

Coat the bushings with the silicone grease.



Next, slide the link eyebolt onto the end of the antiroll bar.

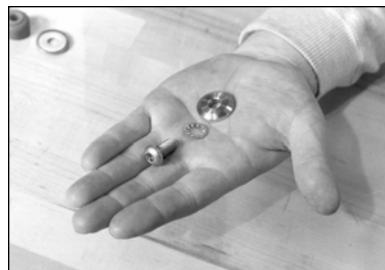

Shown here is the hardware used to attach the link eyebolt to the antiroll bar.

Attach the link eyebolt to the antiroll bar. Place the internal tooth lock washer next to the head of the 3/8-16 x 3/4" button head allen and the beveled stainless steel washer. Apply Loctite™ to the button head allen and tighten.



Put the star lock washer, bushing washer and one urethane bushing on the 3/8-16 x 2 1/4 socket head allen. This attaches the link eyebolt to the lower A-arm. Apply silicone grease to the bushing on all surfaces.

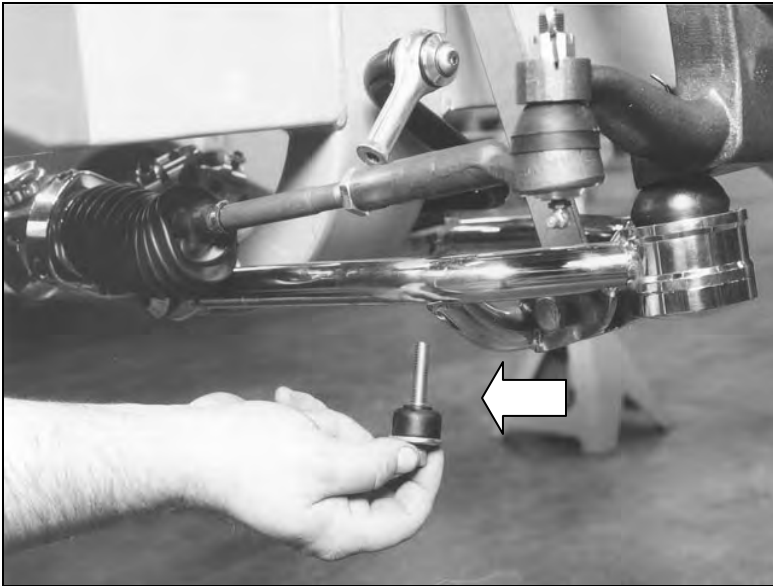

Insert the lower bushing assembly into the lower A-arm mount bracket.



Grease the upper bushing and slide it and the other bushing washer over the bolt.



Apply Loctite™ to the bolt. Push down on the antiroll bar and thread the bolt into the end of the link eyebolt.

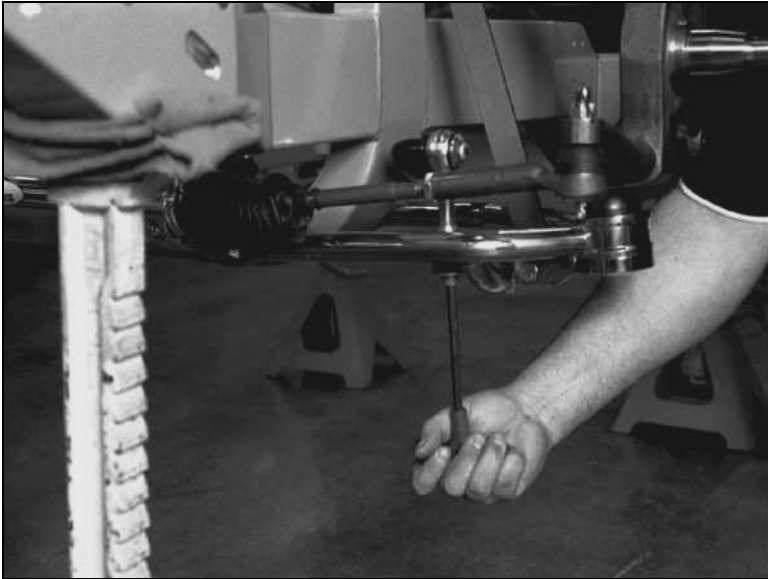

Use the T-handle Allen wrench to tighten the bolt from under the lower A-arm. Tighten only until the urethane bushing begins to crush.

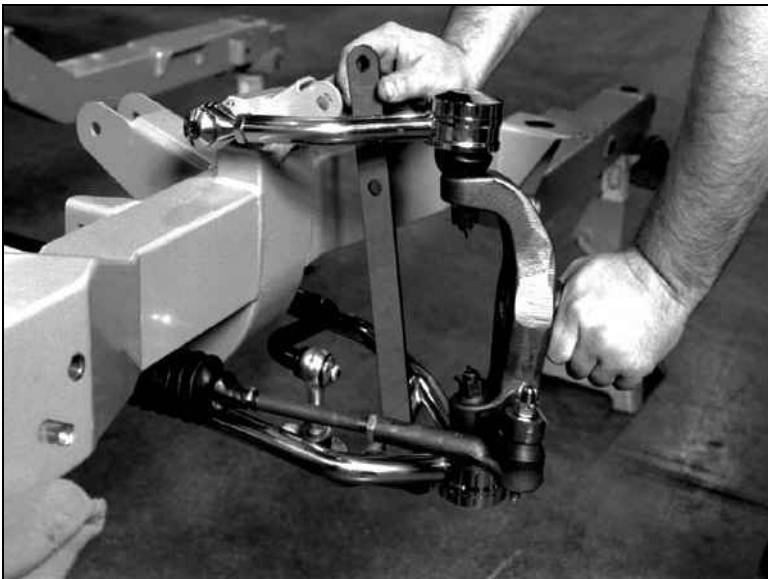

After finishing the antiroll bar installation, run the suspension through its travel full shock extension to full shock compression. Do this with the spindle turned full left, full right, and centered. Everything should move without binding. Because the antiroll bar makes independent installation difficult, you will have to do the driver and passenger sides at the same time.

### ***Installing Shocks & Springs***

The front suspension kit includes the VariShock Quickset 1 externally adjustable coilover shocks with urethane bushings. The knob on the bottom is used to change the ride quality and handling of the vehicle.

Optionally available is a VariShock Quickset 2 double adjustable coilover.





Screw the spring seat adjuster onto the shock. The set screw locking ball allows the spring seat height to be adjusted in  $\frac{1}{2}$  turn increments and then locked once the desired spring height is set.

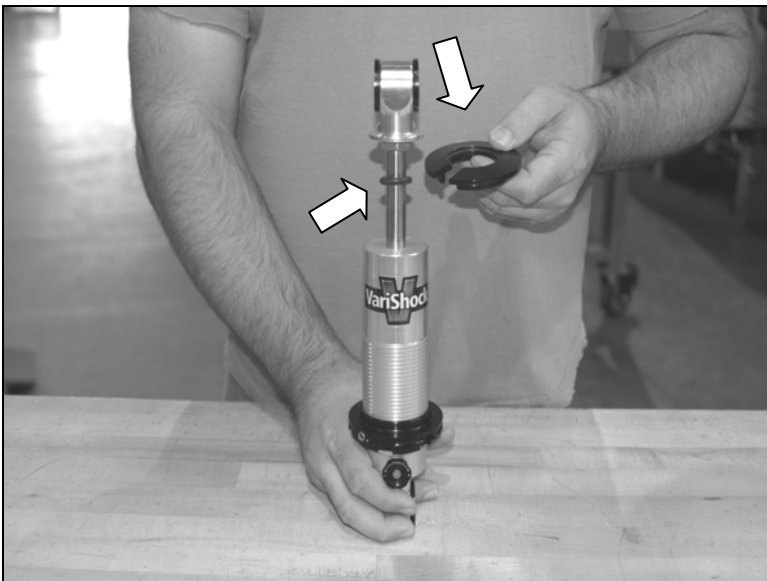

This upper spring seat holds the spring in place at the top of the shock. The slot allows the spring seat to be inserted after the spring is in place.

Slide the rubber bumper down the shock shaft before installing the spring.



After dropping the spring over the shock, slide the upper spring seat over the shaft.



Next, turn the shock over and tighten the spring seat against the spring. After the spring seat makes contact with the spring, turn it one-half of a revolution. This will add a small amount of preload to the coil spring. Tighten the set screw locking ball with an allen wrench. With the spring seat at this position, adjusting the spring seat up or down 1/2-inch can make small changes in the vehicle ride height.

The designed ride height of the suspension has the compressed coilover at 12" eye to eye. If you install a 195/65-15 tire on a 6" wide 15" diameter 3 1/2" backspace wheel, the tire will have 6 1/2" of thread width be 8" wide at the section, have a mounted diameter of 25" and a rolling radius of 12". This will hold the bottom of the crossmember 4 1/2" off the ground. The tire will hold the spindle centerline 12" off the ground. If you use a larger or smaller diameter tire, the crossmember clearance will change accordingly

These are the stainless steel shock mounting spuds used at the top and bottom of the shocks. If you did not purchase these, use the 1/2 x 2-1/2 bolts and locknuts provided with your suspension kit.

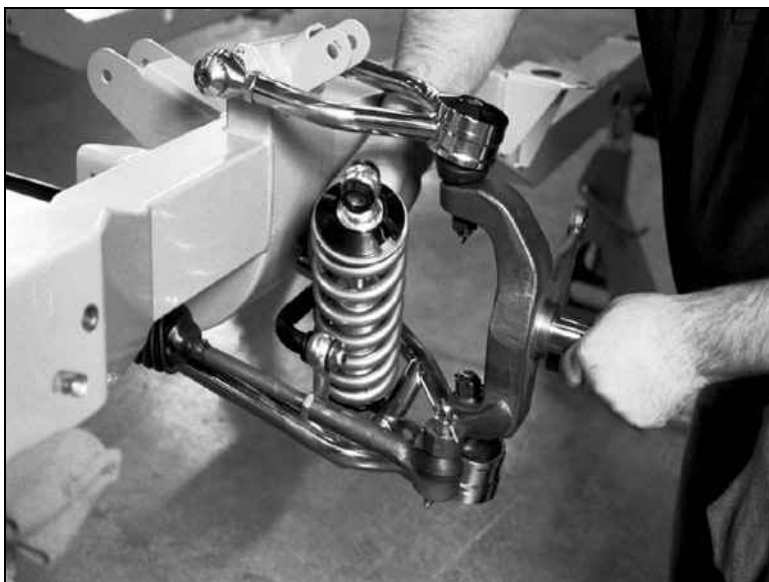

Insert the shock from the bottom. It will fit between the antiroll bar and the lower A-arm shock mount cross tube.

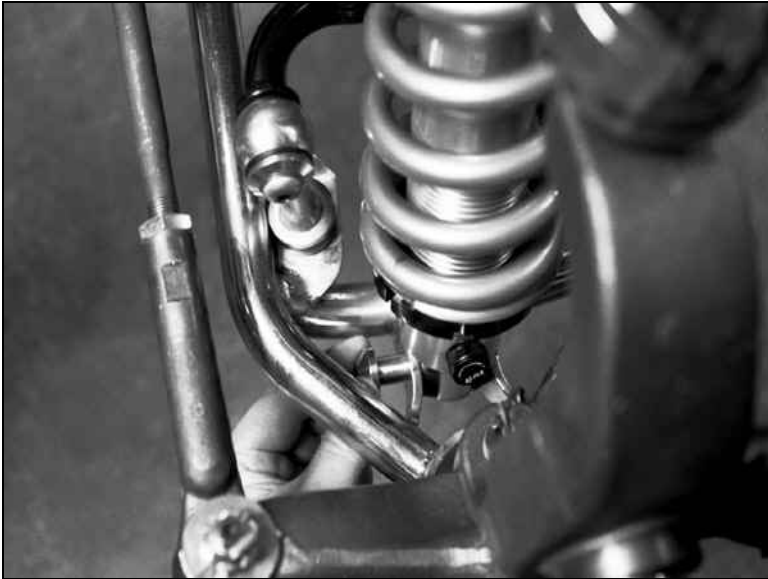

Install the lower shock spud first. Insert the male shock spud from the front of the car into the lower A-arm. Insert the female part of the spud from the back, it acts as the nut. Use Loctite™ to secure threads.



Using the spindle shaft as a handle, line up the top eye of the shock in the upper mount and slide the male spud in. Insert the female part of the spud from the back, it acts as the nut. Use Loctite™ to secure threads.



With both halves in place, use two Allen wrenches to tighten the spud together. Tighten them until they stop, the correct amount of crush is calculated into their length.

## ***Installing Brakes***

The 11 3/4 inch vented rotors are directional. The "P" machined on the inside identifies the passenger side rotor. There is a "D" on the driver side rotor.

These brakes require at least a 15" diameter wheel; however, even some 15" wheels may not clear. Verify you have at least 1/4" of wheel clearance from all brake components.

The billet aluminum hubs have threaded stud-mounting holes for both 4 1/2 and 4 3/4 inch bolt circles.

Choose the bolt circle that matches your wheels and chase the threads with a 1/2-20 tap.

After chasing the threads, it is a good idea to blow them out with an air hose making sure no debris remains in the holes.

Set the rotor over the backside of the billet hub. The larger bearing race snout on the hub is the backside. Line up the bolt circles on the hub and the rotor.



Add a drop of Loctite™ to the threads, up near the shoulder and insert the studs through the proper series of holes. The provided 12-point bolts are 2 1/4 inches long. If you need a longer wheel stud for thicker wheels, 3-inch long studs are available from Chassisworks.

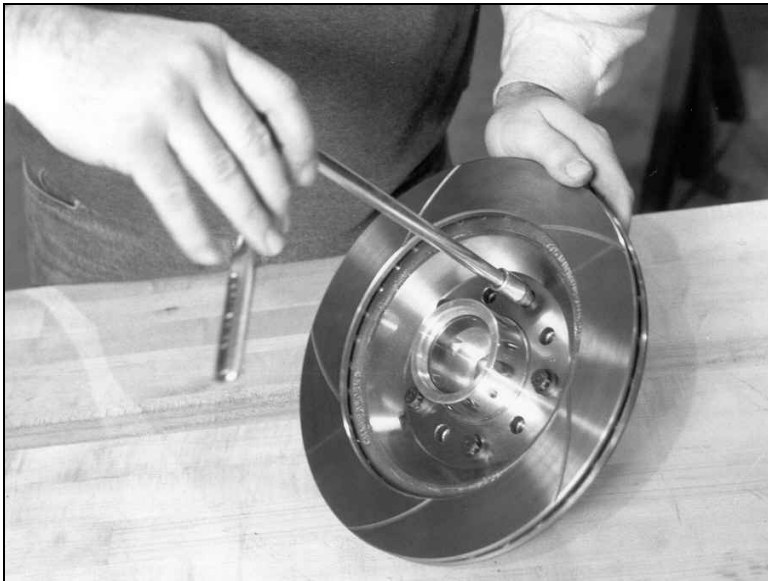

Tighten the studs from the backside of the assembly. You're ready to install the inner wheel bearing and seal.



The bearing races are pressed in the billet hub from the factory. You must pack the wheel bearing before installing it. In the photo, a wheel-bearing packer is shown. If you do not have one available, hand packing the bearing is okay. If you are unsure how to pack the bearing, refer to an auto repair manual for assistance.



After the bearing is packed, drop it in the bearing race. The inner wheel bearing seal is then positioned on the hub.



Place the hub on a wood surface before installing the seal. Using a hammer and seal installer, drive the seal into the hub making sure it's fully seated.

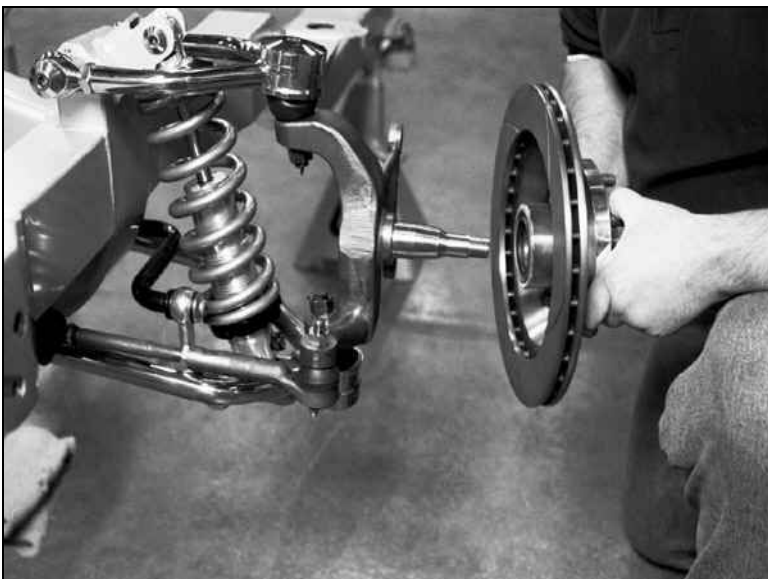

With the inner bearing and seal in place, slide the hub and rotor assembly onto the correct spindle (remember, the rotors are directional).

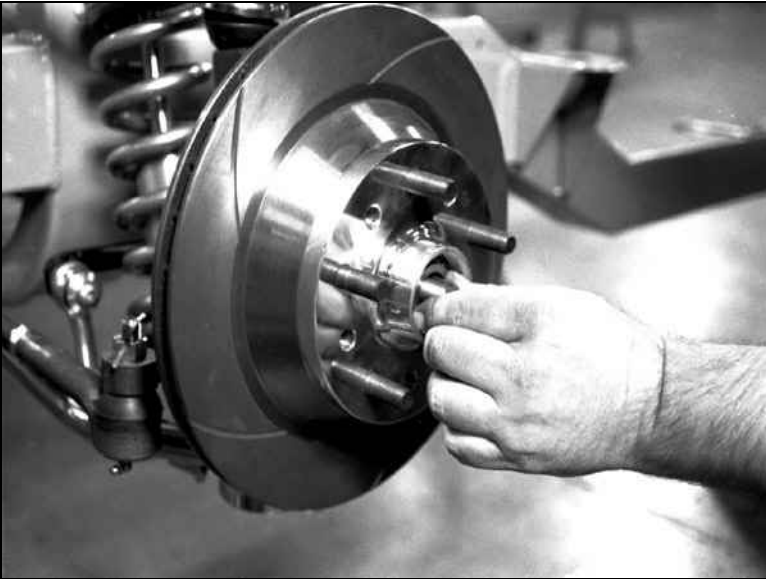

Pack the outer wheel bearing as you did the inner one. Slide the bearing into the race.



Slide the washer over the spindle shaft and install the castle nut.



To fully seat the bearings, tighten the castle nut to 12 lb-ft while turning the rotor assembly forward by hand. This will remove any grease that could cause excessive wheel bearing play. Back off the castle nut to the "just loose" position and then hand tighten. There will be .001 to .005 inches of end play when the wheel bearings are properly adjusted.



After the wheel bearings are tight, insert the cotter pin through the castle nut and the hole in the end of the spindle shaft. Do not tighten the castle nut when aligning the cotter pin; only loosen it.



Use the same procedure you used on the balljoints to fold the cotter pin legs.

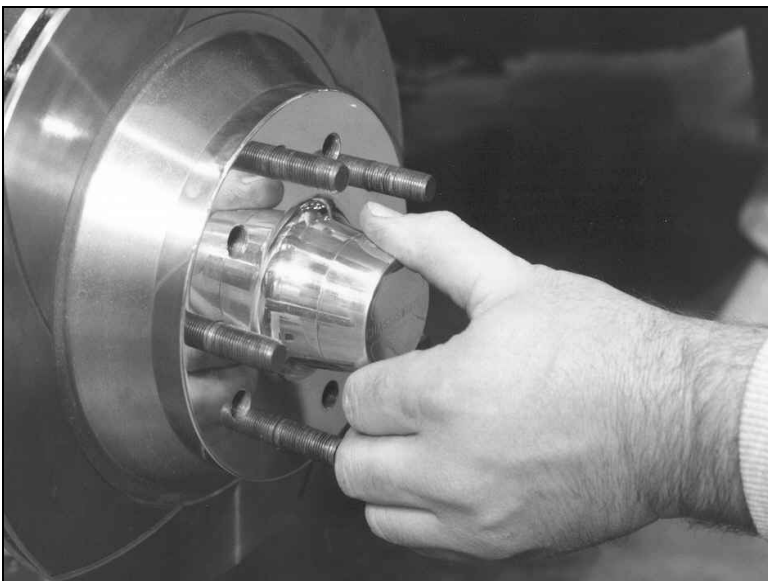

Apply anti-seize to the threads of the screw-on dust cap. Screw the dust cap onto the hub. It only needs to be hand tightened, the o-ring inside will keep it from coming loose.

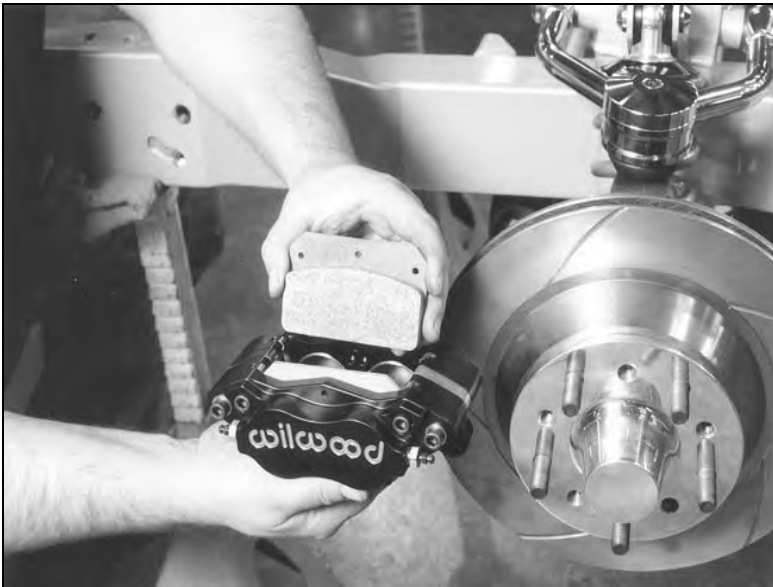

Next, install the Wilwood brake calipers. Start by inserting the brake pads into the caliper, one on each side of the rotor slot with the metal backing toward the pistons.



Slide the caliper with the pads installed over the rotor and the caliper mounting pads on the spindle. Use the 3/8-16 x 1 3/8 socket head allens, lock washers, and flat washers provided in your brake kit to mount the calipers. The lock washer goes against the head of the fastener.



Use the T-handle Allen wrench to tighten the mounting bolts. Rotate the rotor assembly slowly to check for any clearance problems between the rotor and the caliper.



Finally, bolt your wheel and tire on the hub and check again to be sure there is at least 1/4" clearance between the caliper and the wheel. There are differences in wheel manufacturer's tolerances. Make sure your wheel turns freely. **Do not** use positive offset wheels with this suspension system.



Next, remove the plastic plug protecting the inlet port of the Wilwood caliper to start the installation of the stainless steel brake lines.

Coat the 1/8-pipe threads of the 90-degree brake line adapter fitting with Loctite™ teflon sealing compound.



Thread the fitting into the caliper. Be sure to start it straight so you do not cross thread it. If the threads in the caliper get damaged you will have to replace the caliper.



Use a 3/8" wrench to tighten the brake line adapter fitting. The hose end of the fitting should point toward the lower caliper-mounting bolt when tight.

Remember, the caliper is aluminum and the fitting is steel. Do not over tighten and strip the threads in the caliper.



Thread the swivel end of the stainless steel brake line onto the adapter fitting until it is finger tight.



Drill and tap the side of the frame for two 10-32 threaded holes. These holes will position the brake line tab 2" below the top of the frame and 2-1/2" ahead of the weld at the dropped crossmember.



Attach the tab to the frame rail with the stainless steel 10-32 x 3/8" button head and 3/16 high collar lockwasher provided. Use an allen wrench to tighten the button head.

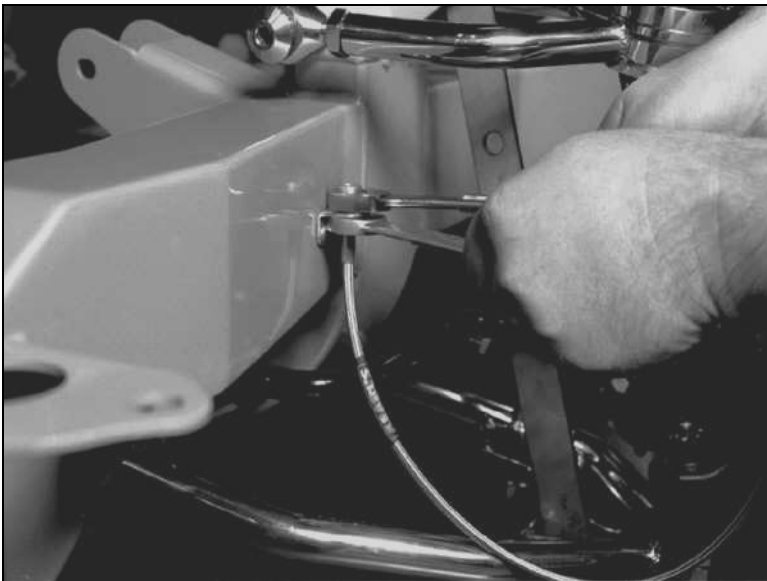

Insert the brake line through the tab and tighten using one wrench to hold the brake line and another to tighten the jam nut.

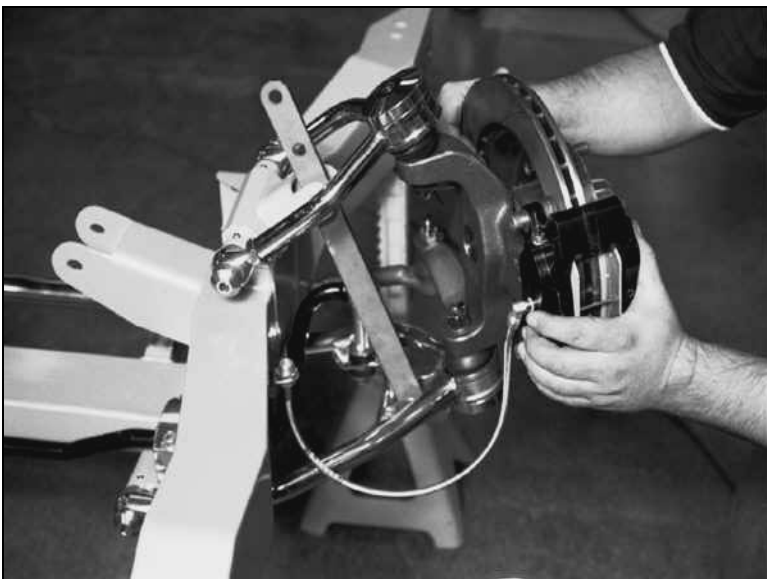

Next, check the brake line for clearance to all suspension parts. Also, be sure the brake line is not stretching or binding while the suspension goes through its full travel and its lock-to-lock turning radius.

Unbolt the driver side end of the anti-roll bar, remove the passenger side coil-over shock and install the shock simulator in the fully compressed position. Turn the spindle to the full left lock position; check the brake line for binding.



Move the spindle to full right lock, check the brake line for any binding.

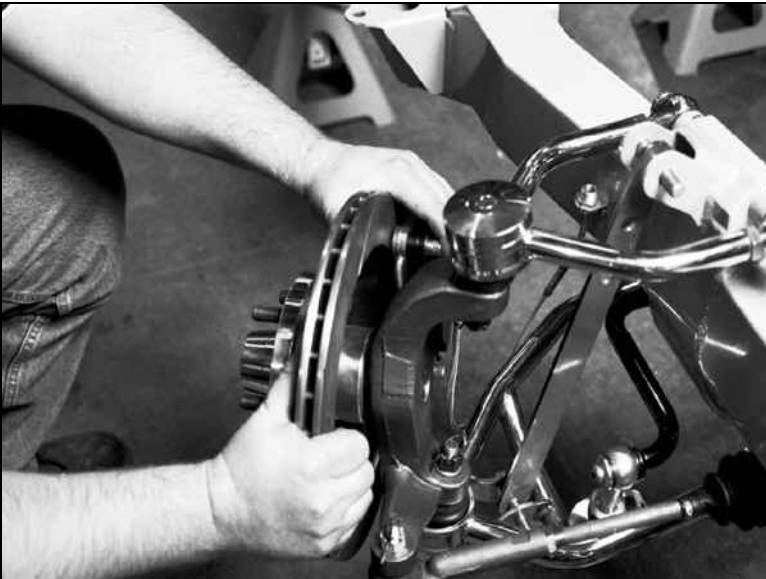

Move the shock simulator to the full extension setting, turn the spindle to full right lock position. Check the brake to be sure it is not stretched.



Turn the spindle to the full left lock position; check the brake line for binding. Repeat this procedure at the ride height setting.



You can now final tighten the brake line at the caliper adapter.

Repeat this procedure for the passenger side brake line assembly.

### ***Installing Billet Engine Mounts & Transmission Mid Plate***

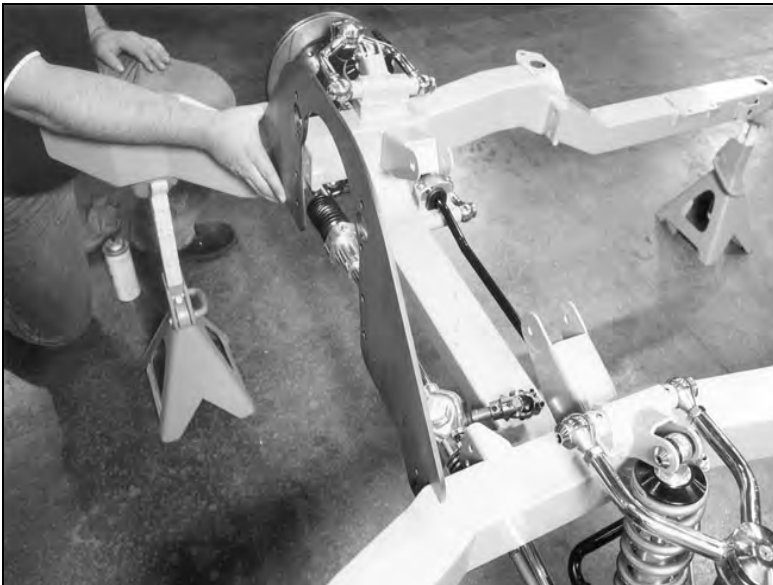

For clarity, some of the engine installation photos are shown without the clip installed in the car. If you have the luxury of a lift available, it is actually easier to set the body onto the frame with the engine and transmission installed. This does present its own problems because it is more difficult to align the body mounting locations. You will need a lot of extra hands and three floor jacks to move the frame and engine assembly under the car. A safety note: The car will be very rear end heavy and tend to tip on the lift. We show how to install our clip on jack stands because we feel it is a more popular installation method.

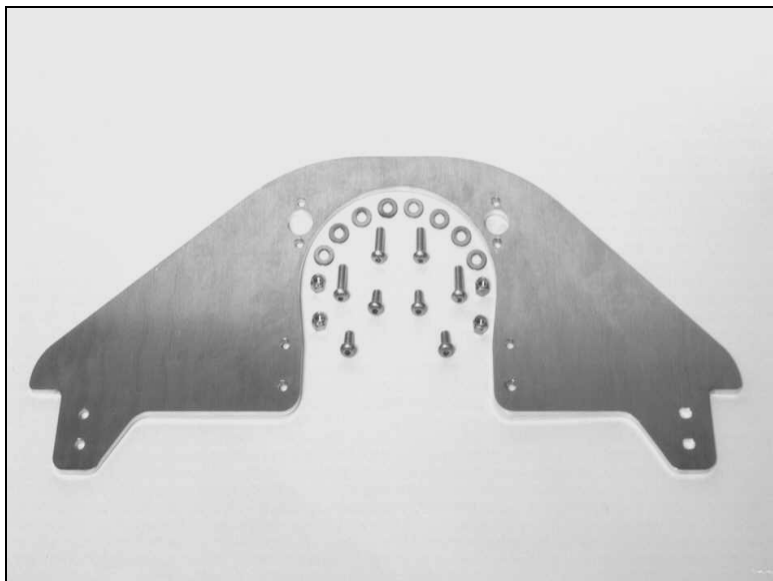

There are two types of motor mounts available; motor plates, and side mounts. The Chassisworks motor plates are available for small and big block Chevy engines. They are shipped completely machined and ready to bolt in. They sandwich between the water pump and block and bolt to tabs that are pre-welded to the frame.



Insert one urethane bushing into each side of the billet mount. Install the steel sleeve into the bushings.

There is no need to lubricate the urethane bushing assembly, it does not rotate.

Repeat the bushing and sleeve installation for the other billet side mount.

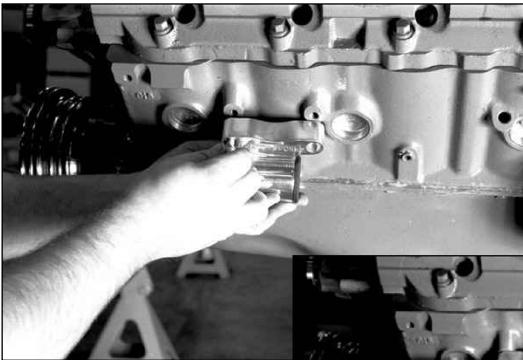

Install the assembled billet mount to the engine block with the stainless steel 3/8-16 x 1 1/2 inch socket head allens and 3/8-inch high collar lockwashers provided. It is best to start all three fasteners before final tightening the billet mount to the block.



Once both billet mounts are installed, you can install the mid plate.

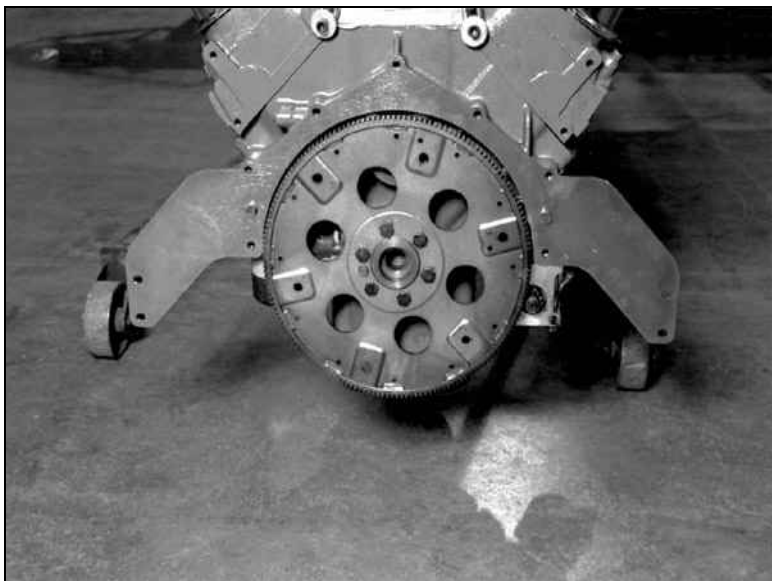

Bolt the automatic transmission mid plate to the back of the engine block. Chassisworks manufactures different automatic mid plates for use with Chevrolet and Pontiac V8.

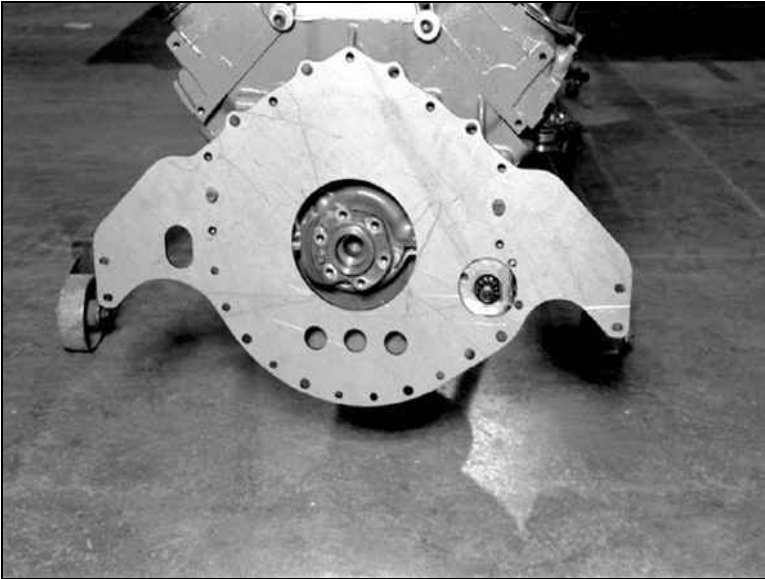

Installation of a manual transmission and Lakewood bell housing will require the mid plate shown here. Chassisworks manufactures different mid plates for Chevrolet and Pontiac V8.



Set the engine in place lining up the billet motor mounts with the frame motor mount brackets. Maneuver the engine into place carefully checking that all parts have sufficient clearance.

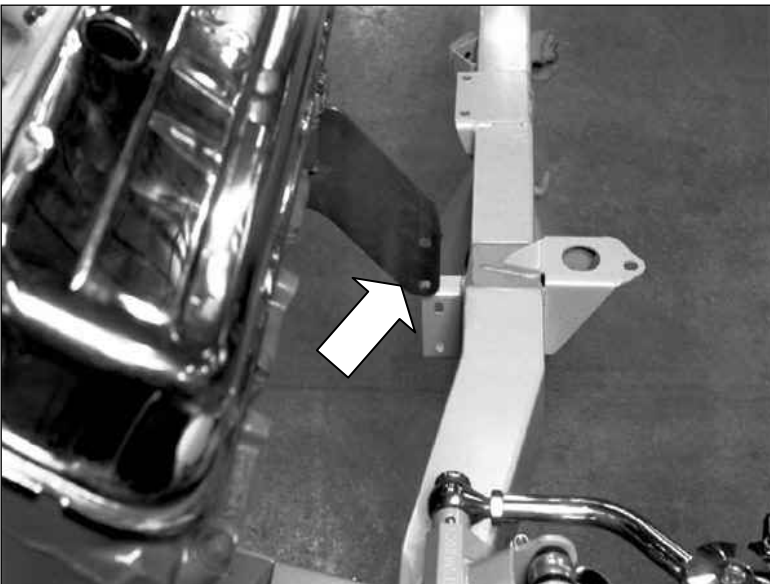

Make sure the mid plate is on the front side on the mounting bracket when setting the engine in place.

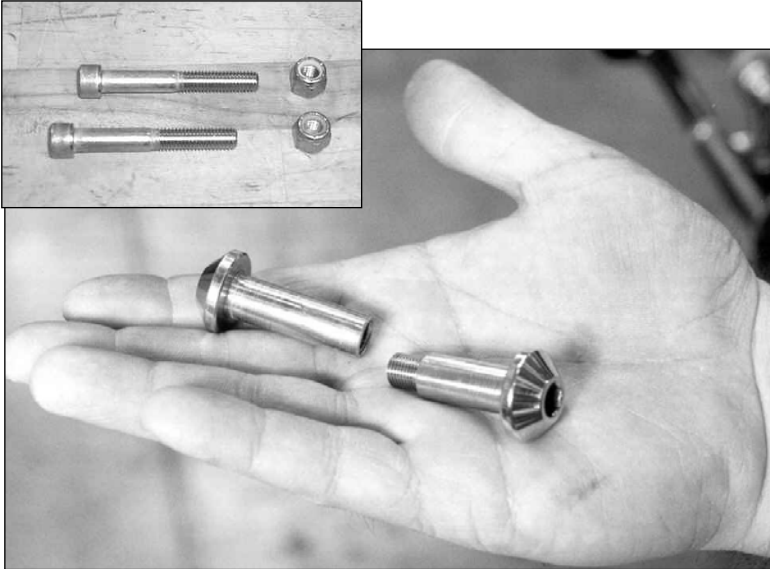

These optional stainless steel "spuds" will be used to fasten the billet motor mount to the frame.

If you did not purchase the spuds, use the stainless steel 1/2-13 x 3 1/2 inch socket head allens and locknuts provided in the billet motor mount kit (shown in upper left).

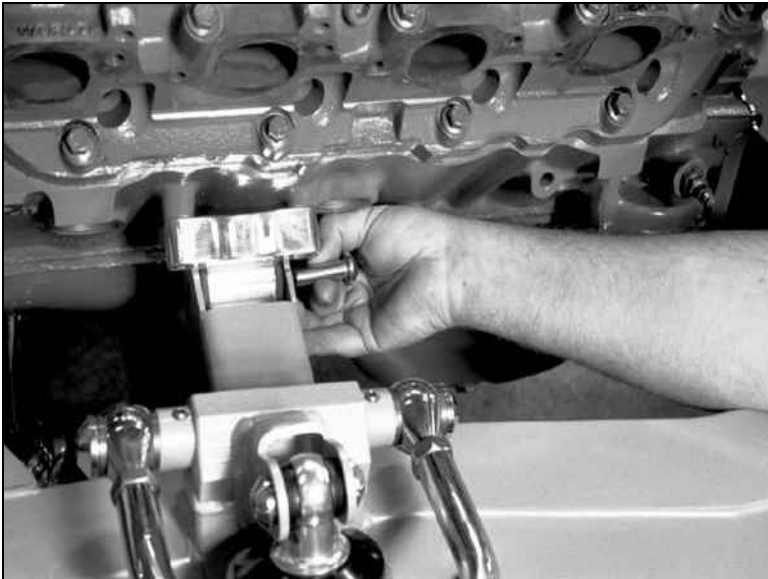

Insert the female spud through the frame mount into the billet motor mount assembly from the rear. Do the driver side first. The passenger side frame adapter has a slot to allow for misalignment.



Apply a small amount of Loctite™ and insert the male portion of the spud through the motor mount bracket and into the billet motor mount assembly. Thread the male and female spuds together and just finger tighten for now.

Repeat this on the passenger side before going to the next step.

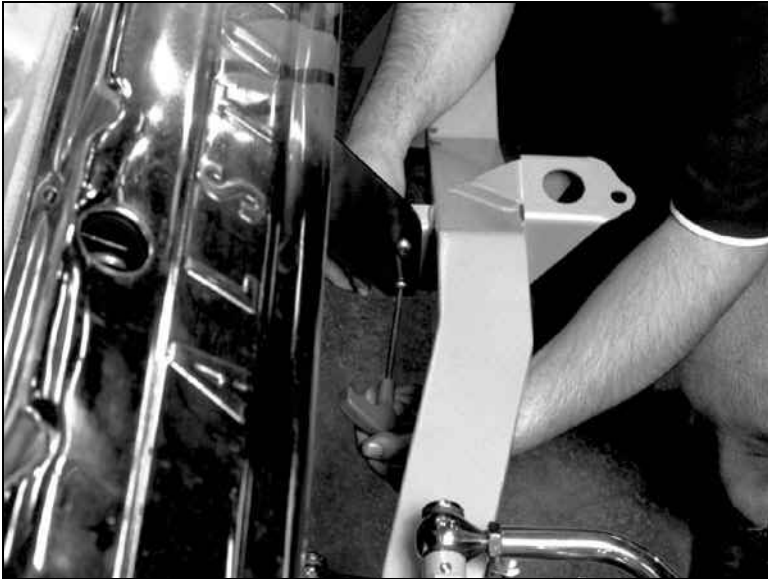

Use the stainless steel 3/8-16 x 1 1/4 inch button head allens, flat washers and locknuts to attach the mid plate to the mid plate mount brackets. Put a flat washer against the button head and another one on before the locknut.

Do not final tighten these until you have the driver and passenger side button head allens installed. Use an allen wrench and a 9/16 inch wrench to final tighten the mid plate button heads allens.



Final tighten the motor mount spuds using two allen wrenches. Torque them to 20 lb-ft.

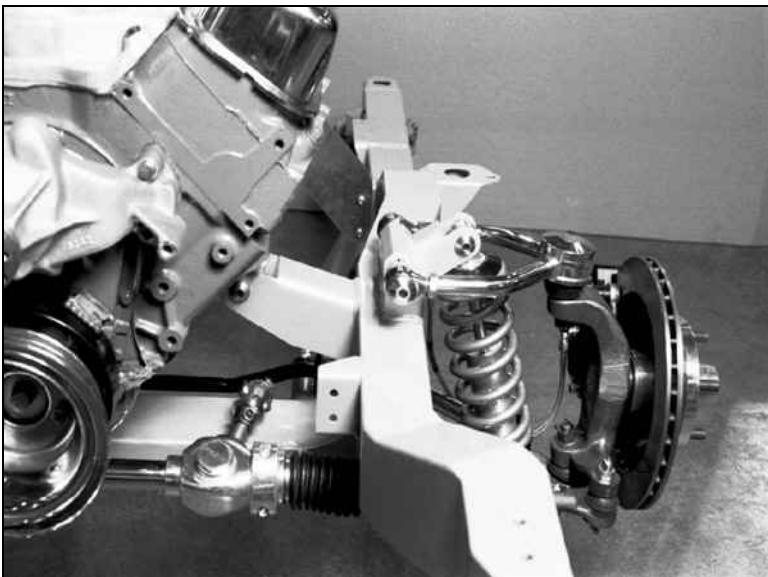

The engine is now mounted and ready for the transmission.

***Installing Manual Transmission,  
Clutch Linkage and  
Lakewood Can***



Chassisworks manufactures a different replacement block saver midplate for use with the Lakewood clutch can for Chevrolet and Pontiac engines.

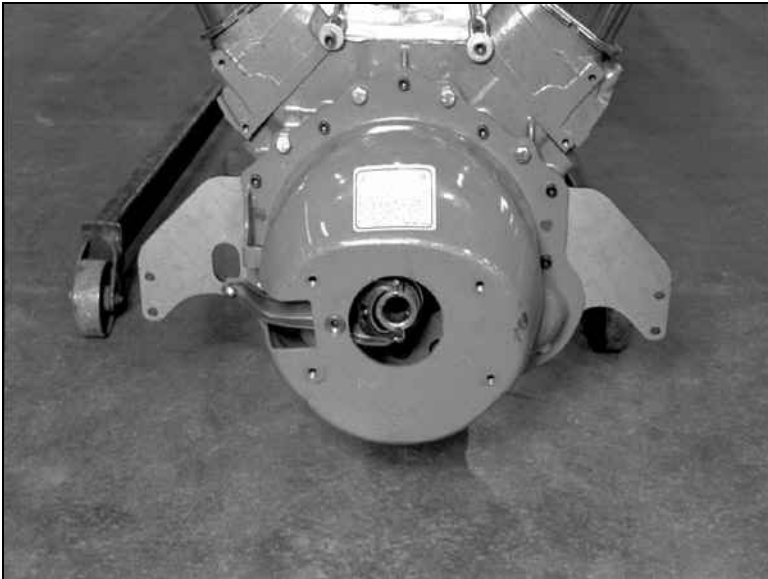

The block saver mid plate uses all the standard Lakewood hardware to attach to the engine.

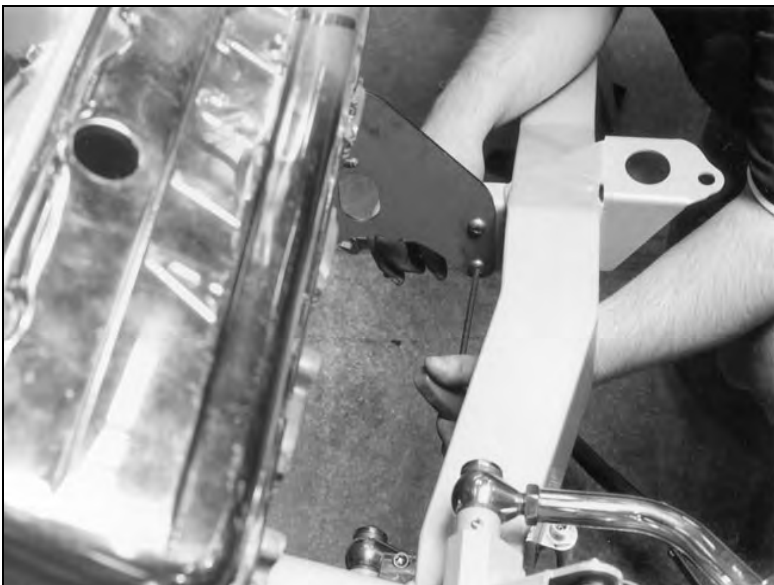

The block saver mid plate attaches to the Chassisworks frame the same as the automatic transmission mid plate.

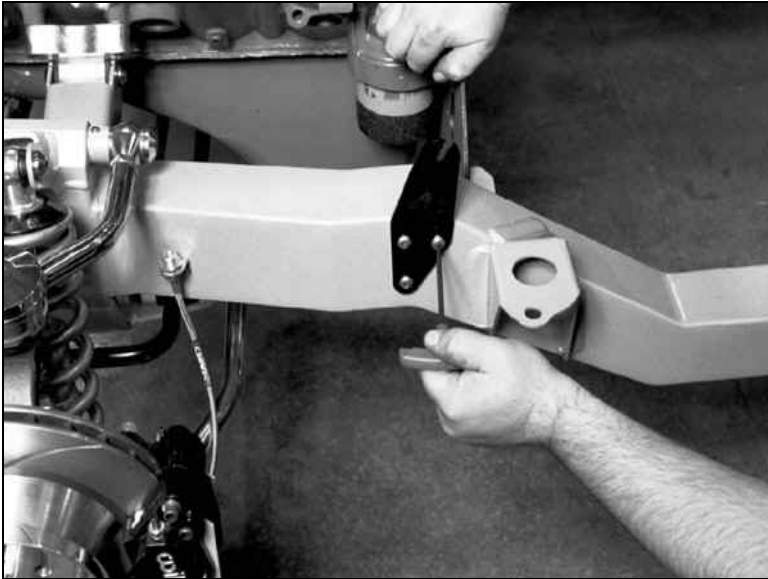

To install clutch linkage, bolt the optional torsion shaft outer support to the frame as shown.



Install the clutch linkage torsion shaft and linkage as in the stock car. Some blocks do not have a pivot ball hole for the other end of the torsion shaft. Chassisworks has an optional bracket to solve this problem.



5916-F10-01 - 4-Speed, Powerglide, Turbo 350



5916-F10-02 - 700R4, Tremec, Richmond 5-speed, 4L60



5916-F10-03 - Turbo 400, 200-4R, 4L65E



5916-F10-04 - Richmond 6-speed ROD

Chassisworks currently manufactures transmission crossmembers for most applications. Not all automatic transmission deep pans will clear the Chassisworks crossmembers. The Turbo 350 is the most varied.

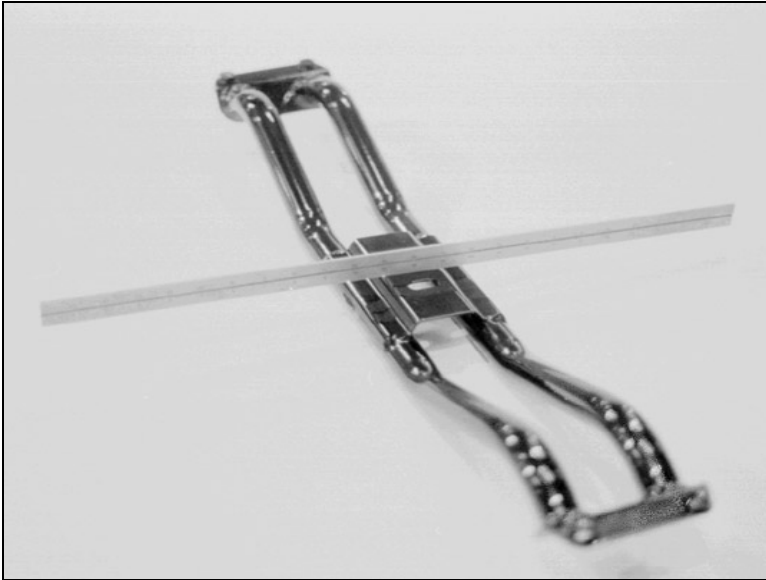

Item 5916-F10-01 4-Speed, Powerglide, Turbo 350 crossmembers must be installed so the transmission mount surface slopes down hill to the rear of the car. To determine which way the crossmember installs, place a straight edge on the transmission-mounting pad to determine its slope.

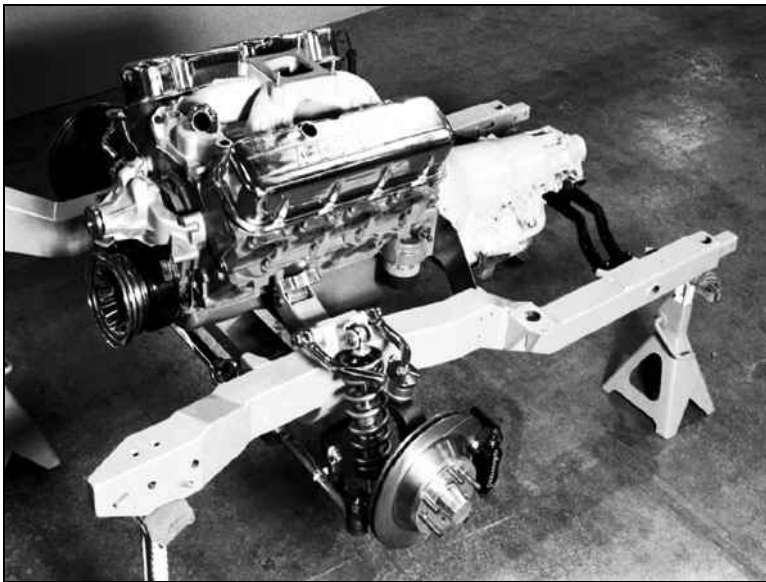

These two photos show an engine and Turbo 400 installed.

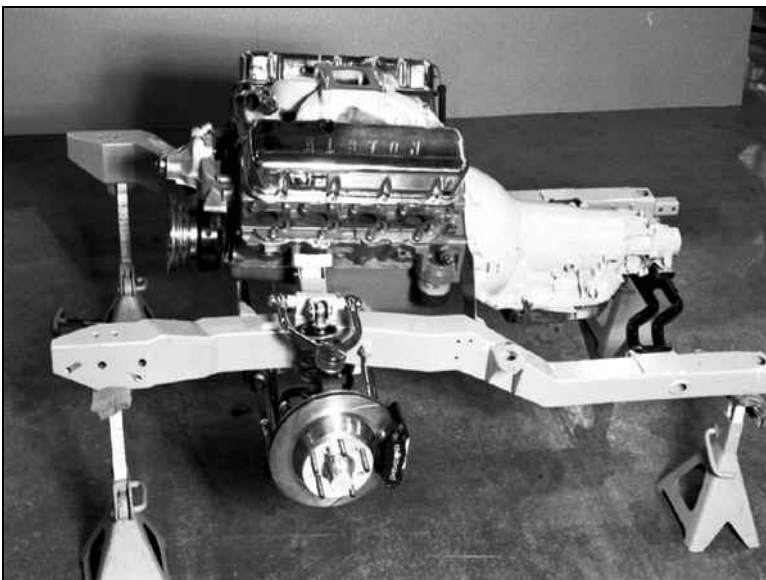

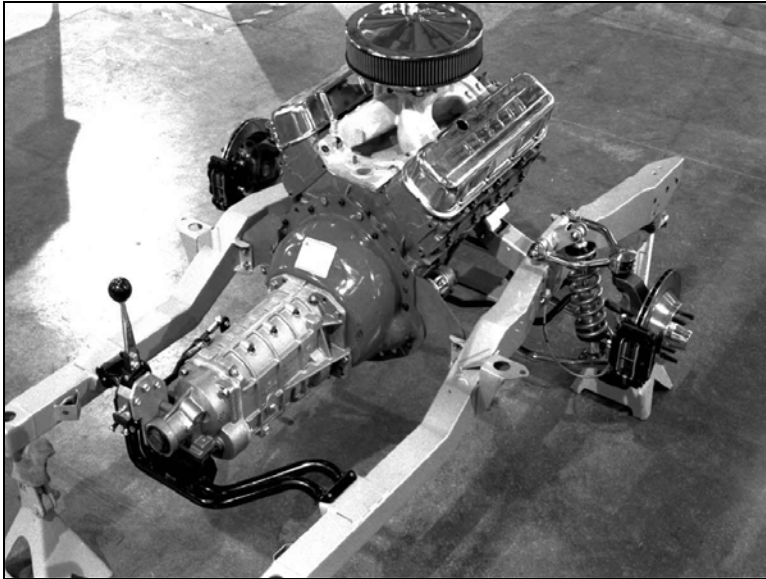

These two photos show an engine and Richmond 6 speed installed.



### ***Removing Stock Front Clip***



The first step is to remove the hood, engine and transmission. This will make it easier to see and work in the engine compartment. It is also important that the gas tank is empty so fuel cannot siphon out when the fuel line is disconnected.



After you remove the engine, place your vehicle on jack stands. The jack stands must be supported by a level concrete surface at least as large as the car. Put two stands under the rocker panels about 4" in front of the front door. Put two stands under the rear axle. These stand locations will prevent the car from tilting backwards when you remove the front clip. **DO NOT REMOVE THE FRONT SHEETMETAL.**



This is a view of the passenger side inner fender panel before we removed any components.

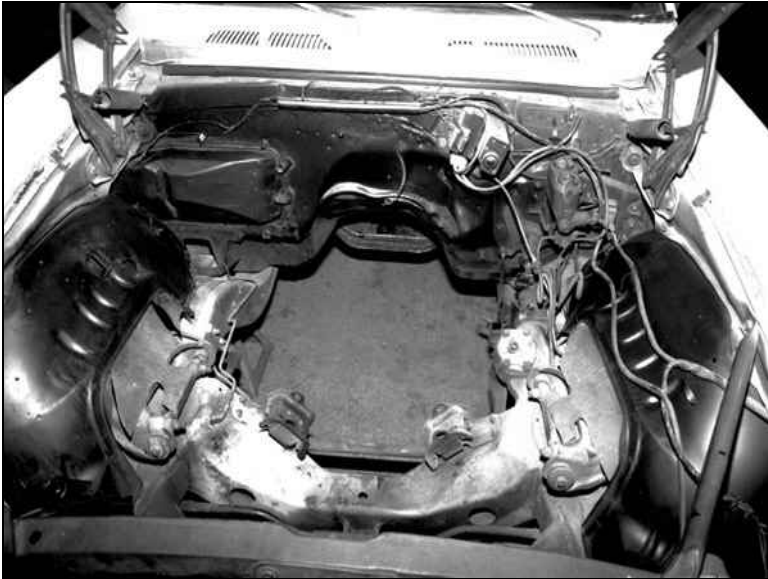

This is a view of the firewall before we removed components.

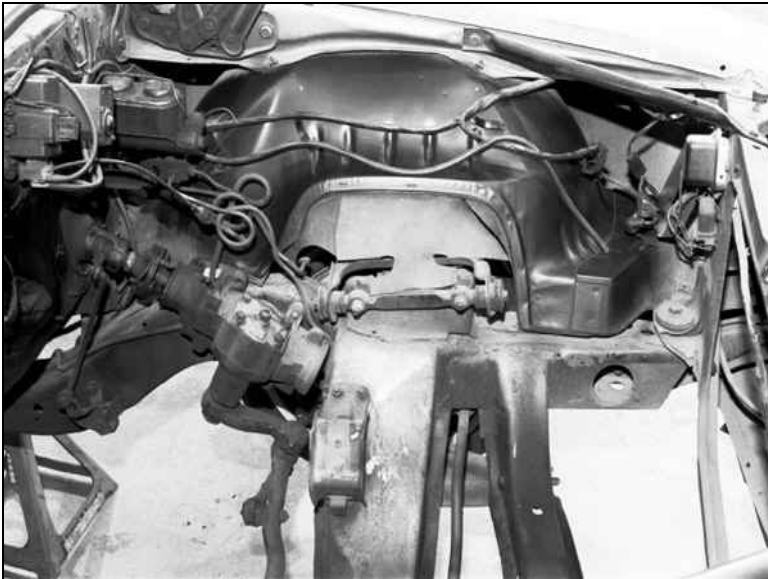

This is a view of the driver side inner fender panel before we removed any components.



Your car should look like this with the hood removed and positioned on four jack stands before you go any further.



Use vise grip pliers and an end wrench to disconnect the parking brake adjuster mechanism.



Use vise grip pliers to remove the spring clip from the parking brake cable adjuster.



Remove the parking brake cable from the frame on the driver side.

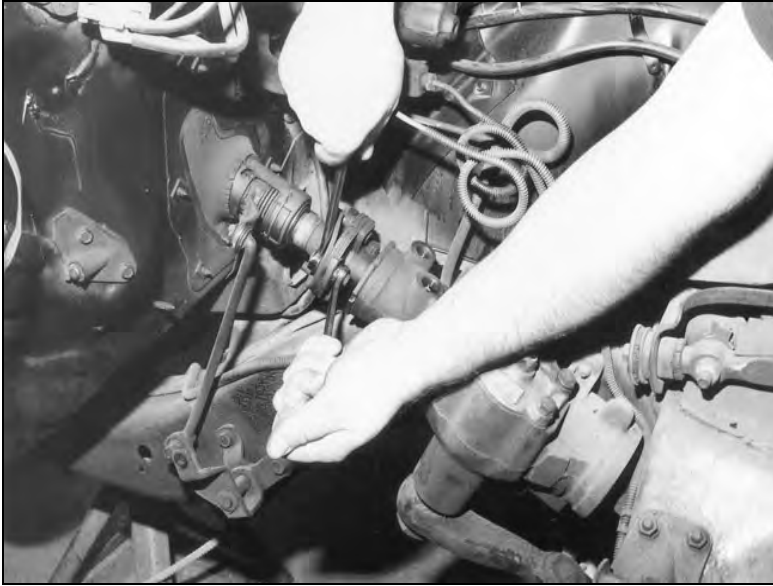

Disconnect the steering column from the rag joint using end wrenches.



Use a pair of pliers to remove the cotter pin that holds the transmission linkage to the steering column lever.

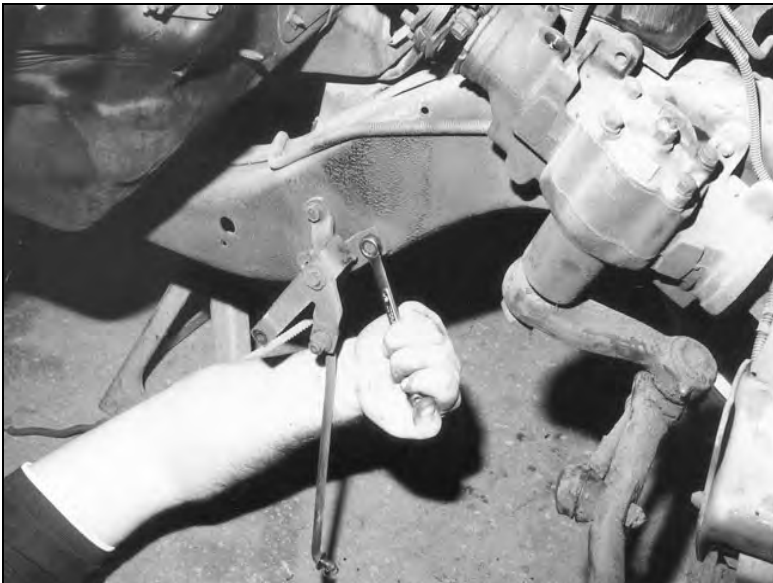

Disconnect the transmission linkage bracket from the frame so it won't hang up on something when you slide the frame out from under the car.

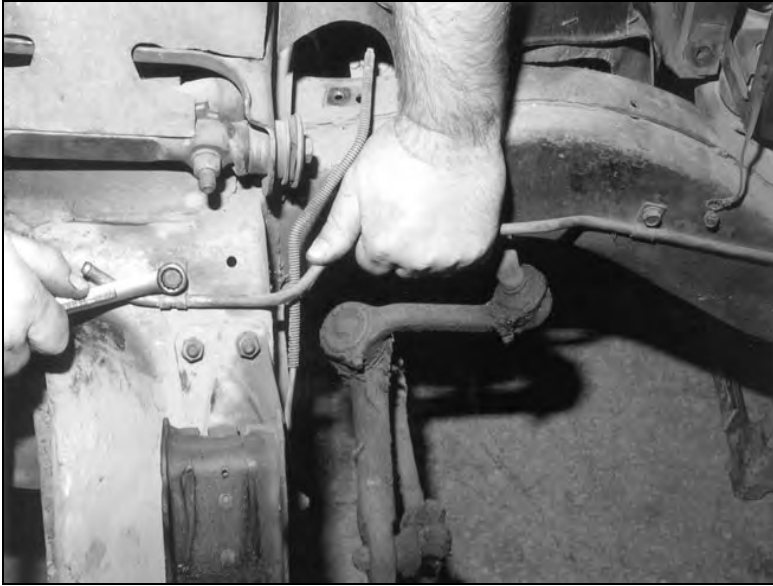

Disconnect the clamps that attach the fuel line to the frame. Remember for safety, the gas tank needs to be empty.



Use a piece of string to tie the fuel line up out of the way. Also, disconnect the ground strap from the frame.

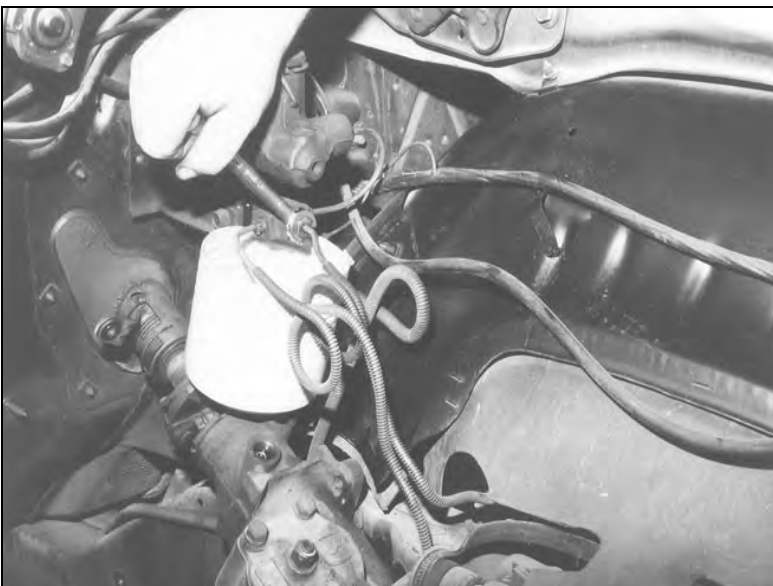

Using a brake line (flare nut) wrench, disconnect both the driver and passenger front brake lines from the metering block under the master cylinder.

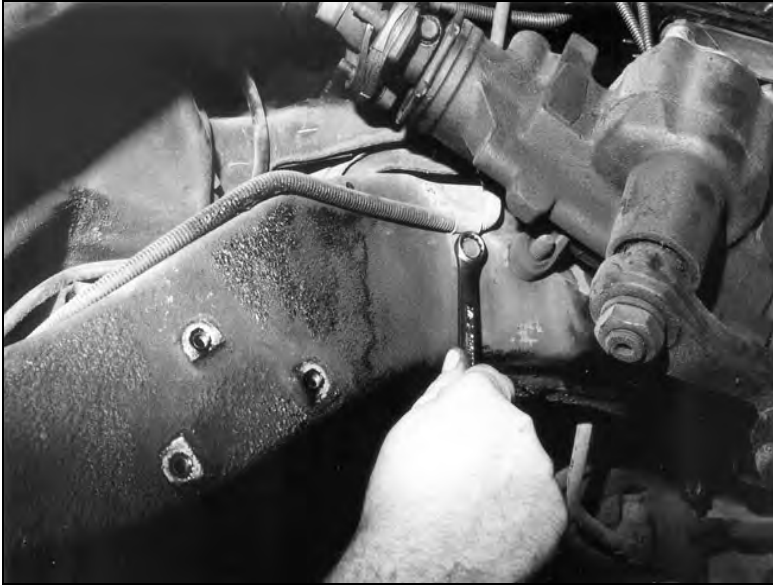

Disconnect the brake line clamp by the steering box.



From under the floor, disconnect both brake line clamps on the outside of the driver side frame rail.



Remove the battery tray for easier access to the front frame bolts.

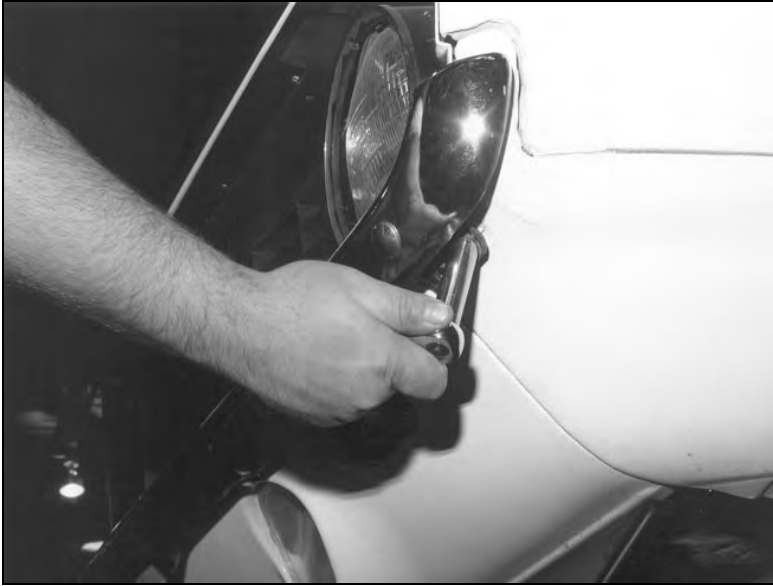

Remove the bolts that attach the ends of the bumper to the body.



Remove the bolts that attach the bumper to the frame bracket.



Remove the bumper brackets from the frame.



Remove the bolts that attach the radiator core support to the frame.



Slide a floor jack under the front clip and center it on the drag link, this is the best balance point. Raise the jack so it has slight pressure on the drag link to hold the frame up. Do not lift the car up off of the jack stands.



Remove the rear frame mount bolts.



You need three people; one to operate the jack; one to steady the frame by holding on to the spindle through the wheel well; and the third person will remove the frame bolts at the firewall.



Remove the center frame mount bolts. Do not get under the car in case the frame falls.

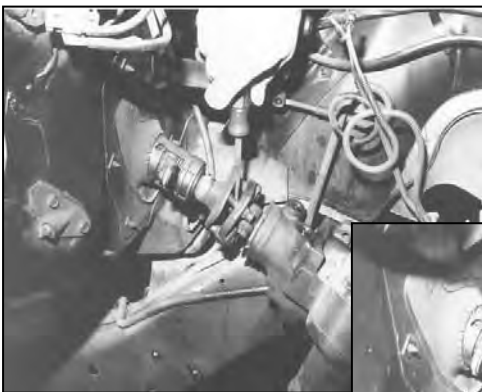

After all the frame mounts are removed, the third person needs to pry the rag joint forward off of the column. The frame must slide forward.

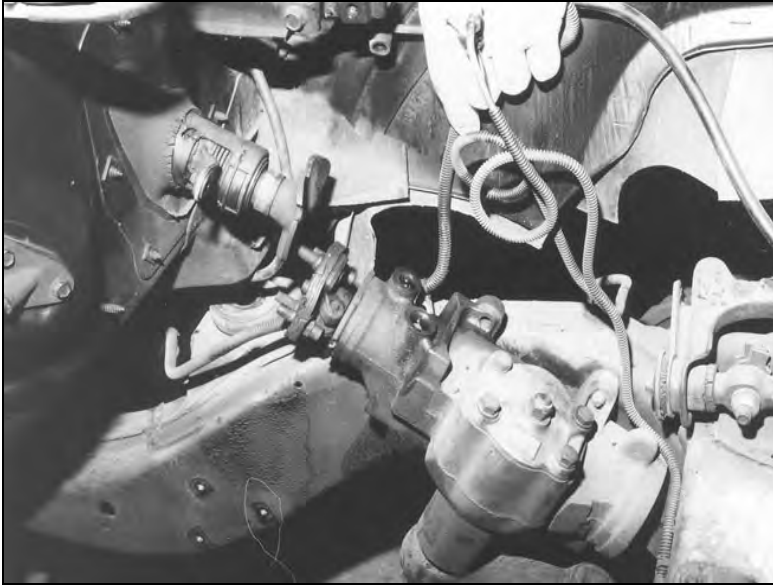

Only slide the frame forward enough to disconnect the rag joint. The front frame horn to the front-end sheet metal's lower valance. Clearance is minimal; do not bend the lower valance with the frame horn.

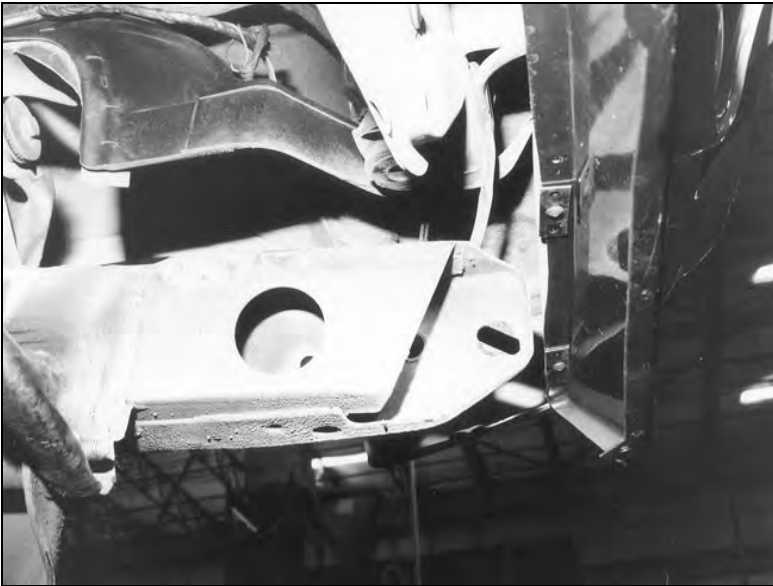

Lower the frame until the rag joint is below the steering column and then push the frame rearward about 6" to clear the valance. You will have to tilt the frame up a the front while you do this to prevent bending the valance



Lower the clip to the ground and pull it out toward the front of the car.

### ***Installing Bolt-On Frame***



These are the Chassisworks provided frame alignment pins.

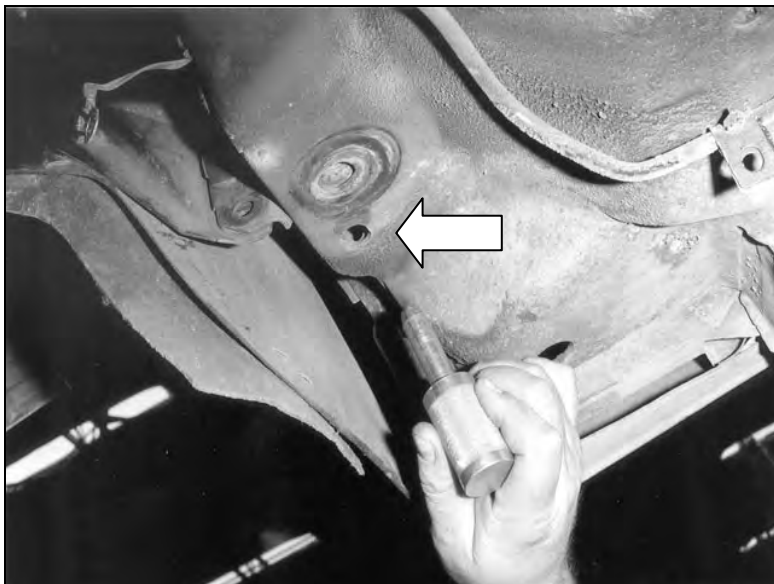

This photo shows the passenger side frame mounting location at the firewall. Notice the slotted hole beside the bolt hole for the body mount. The alignment pin is used to align the front frame during installation.

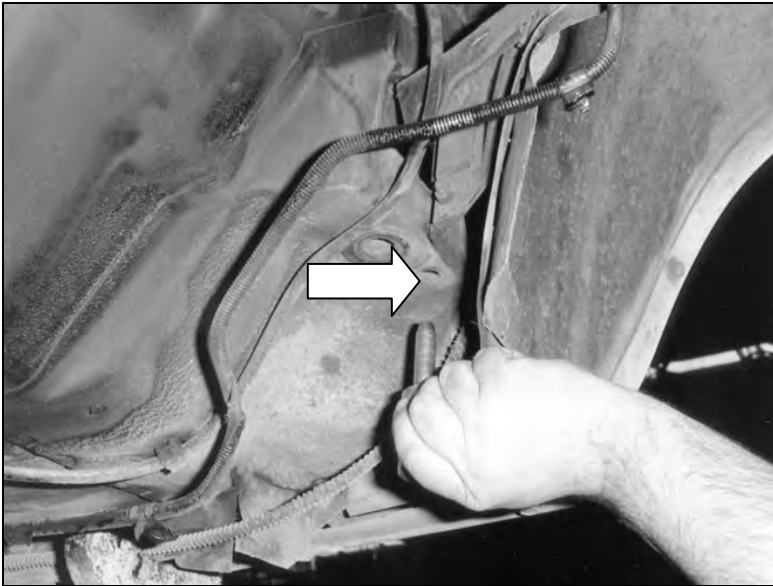

This photo shows the driver side frame mounting location at the firewall. Notice that it's alignment pinhole is round.

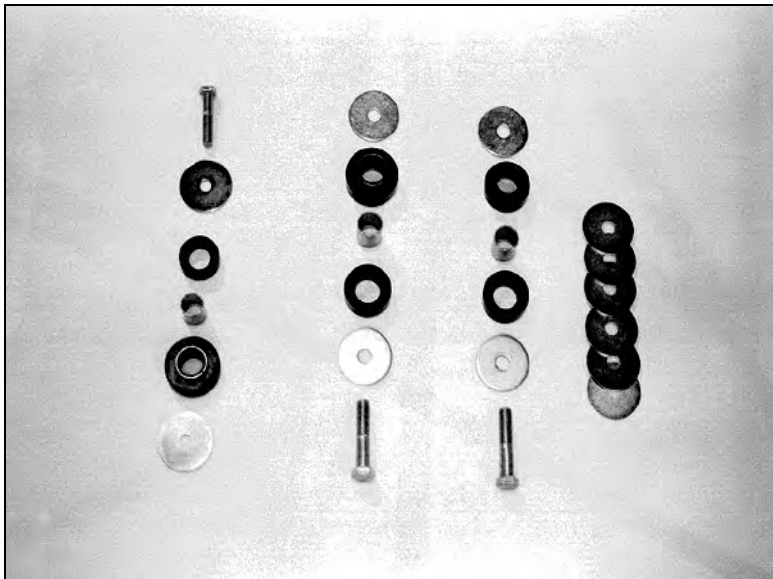

These are the components of the urethane bushing set for one side of the car. They are laid out how they are installed with the left side toward the front on the car. The eight 2-1/2" OD silver body shims may not be needed in your application. Some bodies or their front sheet metal will require that the frame be shimmed to take up the gap at the front valance panel.

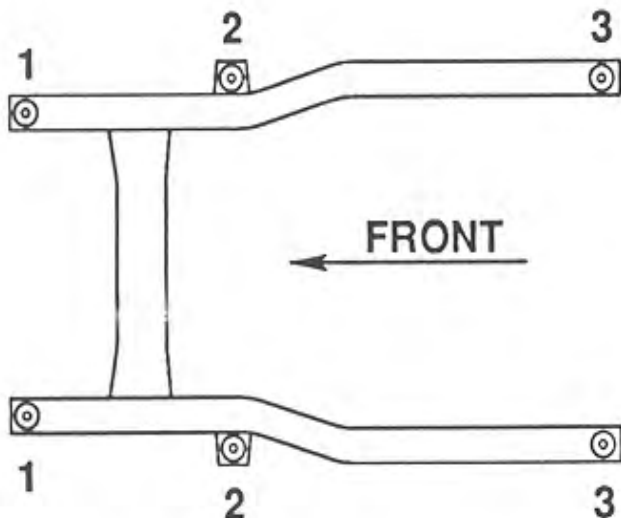

### # 1 POSITION BODY MOUNT

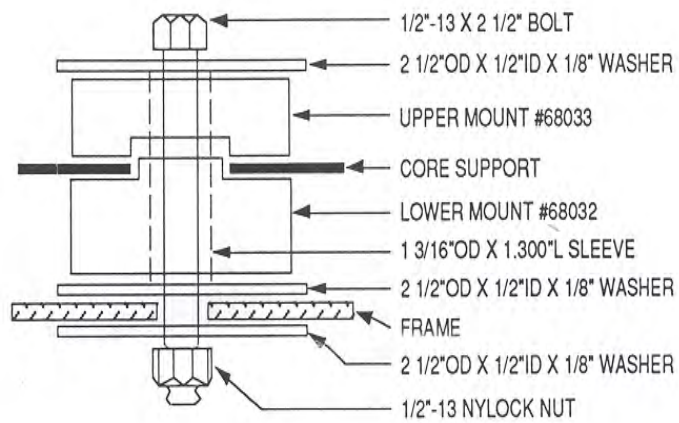

This is the correct orientation of the front urethane body bushings at the radiator core support.



This is the correct orientation of the middle urethane body bushings at the firewall.

## #2 POSITION BODY MOUNT

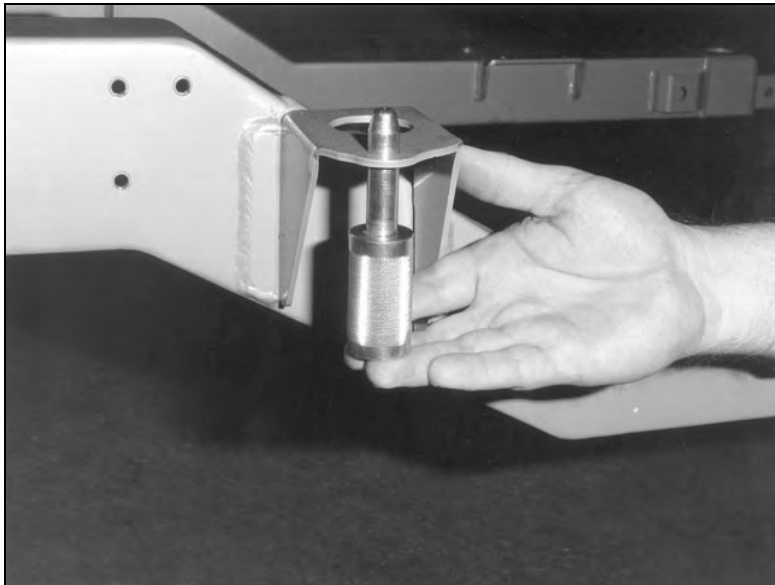
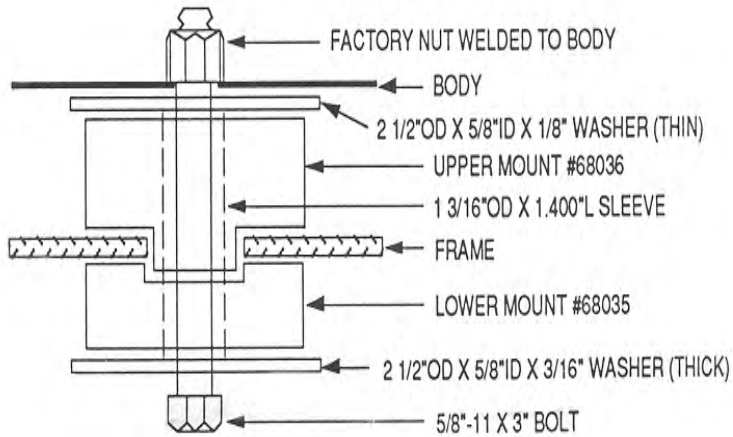

The alignment pins slide up through the 5/8" hole beside the middle body mount.

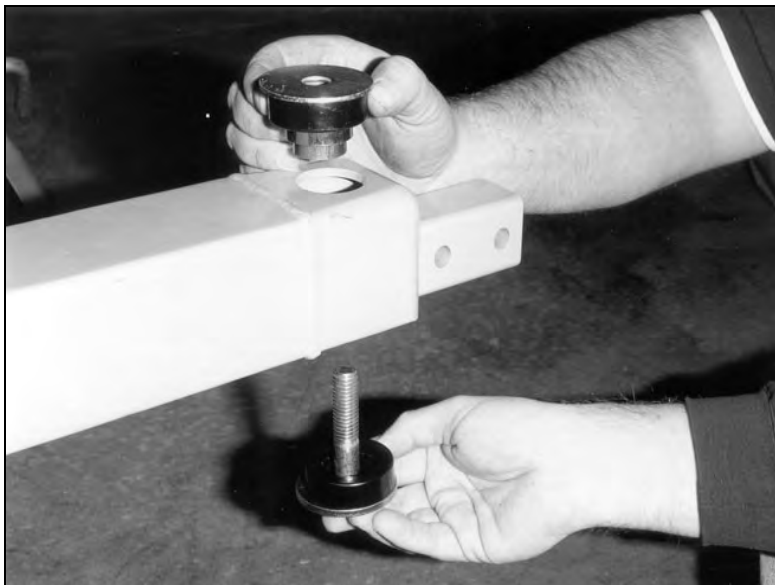

This is the correct orientation of the urethane body bushings at the rear of the frame where it mounts under the seats.

### #3 POSITION BODY MOUNT

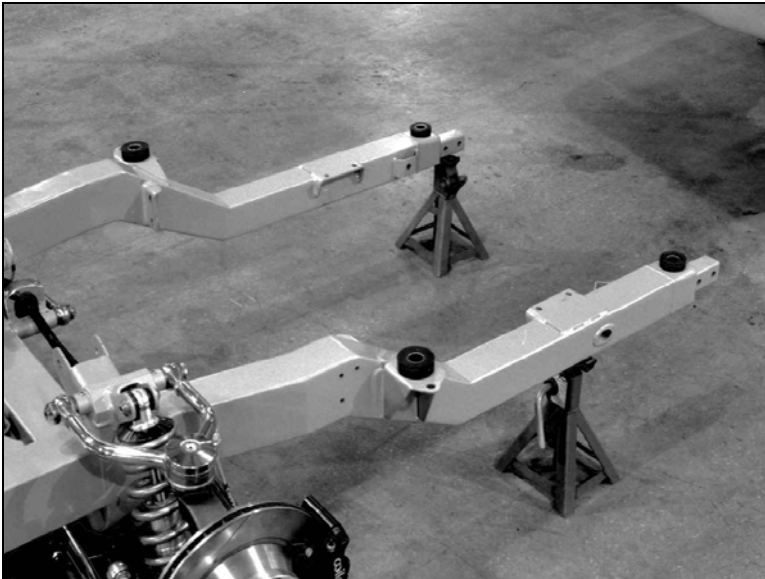
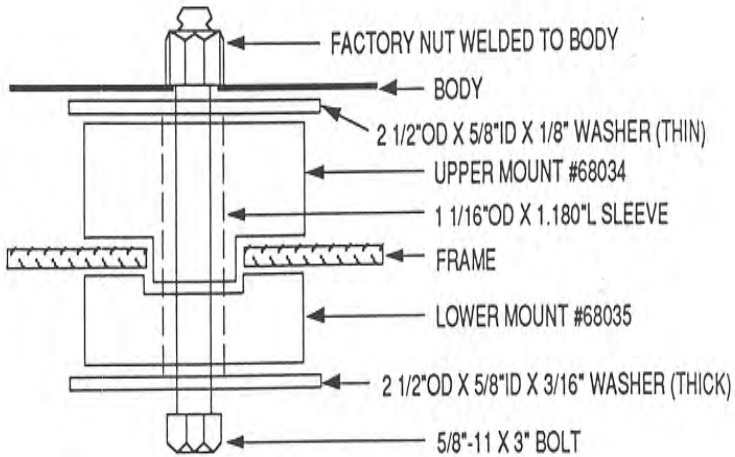

Place the top part of the mid and rear urethane body mounts into their mounts before the next step.



Place the dropped crossmember portion of the new Chassisworks frame clip on the floor jack and slide it under the car.

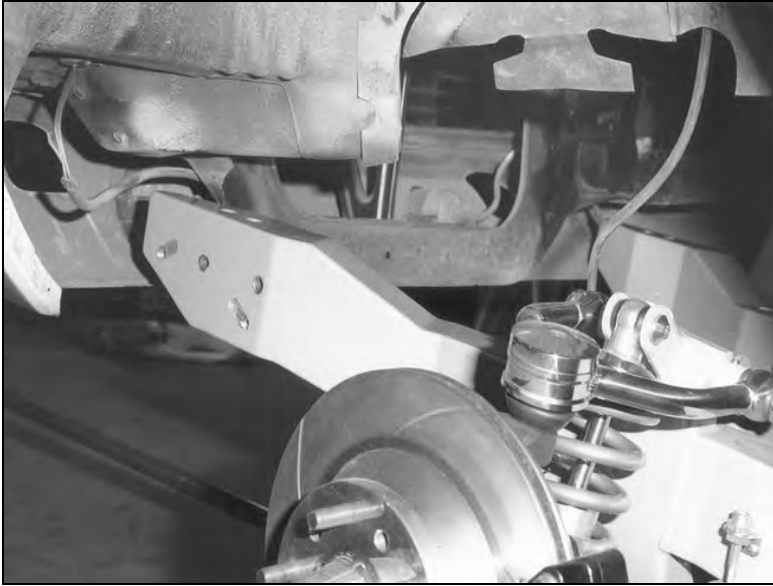

Jack the clip up with the frame on a slight angle. The front of the clip needs to be above the rear. This will allow you to slide it up above the valance. Be careful not to bend the valance. Once the front of the frame is above the valance, jack the frame up so it is flat against its middle and rear body mounts.



Lower the front of the frame just enough to install the lower half of the urethane body mount.

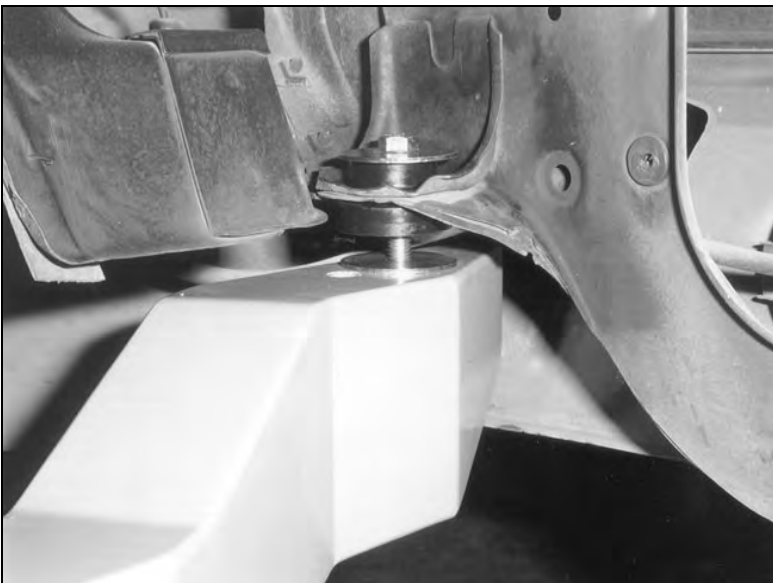

Install the upper half of the urethane body mount and screw the 1/2" bolt into the frame at least 1/2", however, the bushing must be loose.

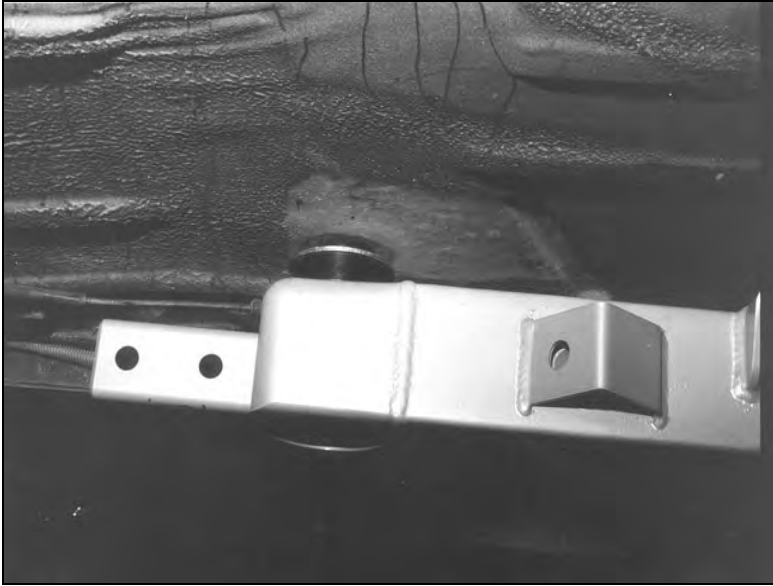

Install the lower half of the rear urethane body mount but do not tighten it. Leave the bolt loose.



Install the lower half of the middle urethane body mount. Again, do not tighten it. Leave the bolt loose.

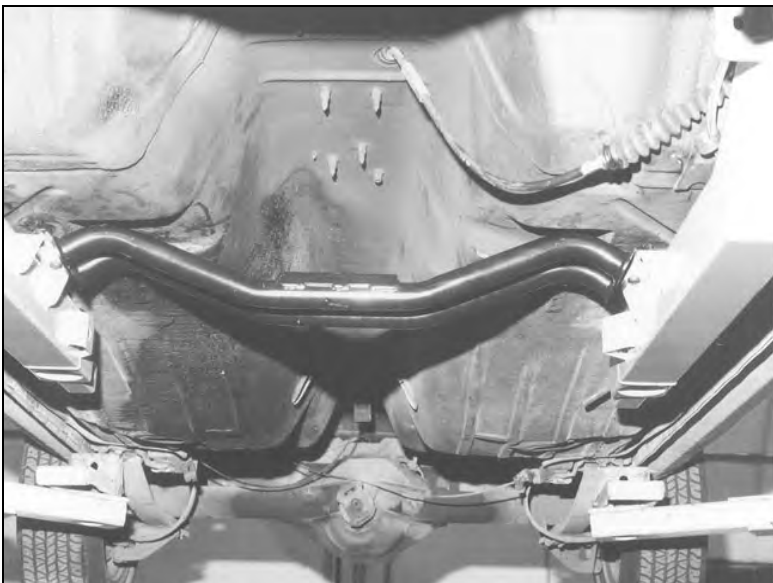

### ***Installing The Transmission Crossmember***

Before we align the frame, install the transmission crossmember. The crossmember must be installed before tightening the frame to the body. The frame can be flexed when tightening to the body so if the crossmember is not installed, it may not fit later on.



The transmission crossmember is designed to raise up into the pocket in the floor. This provides extra exhaust clearance. The transmission crossmember may have to be slapped to get it into location. A firm slap with the palm of your hand will usually do the trick. A plastic hammer would also work.



Tighten the transmission crossmember bolts before bolting on the frame. If the transmission crossmember mounting bolts do not fit centered in their slots, have someone pull the frame apart or, press it together while you tighten the bolts. This will make the crossmember easier to remove and reinstall after the frame is bolted to the body. Also, some of the more swept back crossmembers (like the Turbo 400 model) will touch the floor slightly after they are installed. If this condition causes a rattle in your car, use a body hammer to push the floor up where it hits the crossmember.



### ***Aligning The Frame***

The first step in aligning the front end is to put the alignment pins in both the firewall body mounts. Do not remove any of the other body bushing bolts. If your front sheet metal is correctly installed, getting both pins in will be easy. Do not expect the radiator core support 1/2" bolts to be centered in the urethane bushing sleeves. If it appears that your core support won't allow the frame to be positioned correctly, remove the front body mount bolts and continue with the alignment procedure. Push the driver side alignment pin against the body mount bracket and tighten the body bushing. Repeat this procedure on the passenger side.



Measure from the lip on the rocker panel to the side of the frame clip at the front of the rocker panel and the rear of the frame. Bump the frame around until the frame is parallel with the rocker panel on each side and the same distance from the frame to the rocker lip on each side. If the lip under the rocker panel is not straight, use a body hammer and dolly to straighten it before measuring. Try to bump the frame around so that the largest measured difference between any two of the four rocker panel lips is less than 1/4 inch.

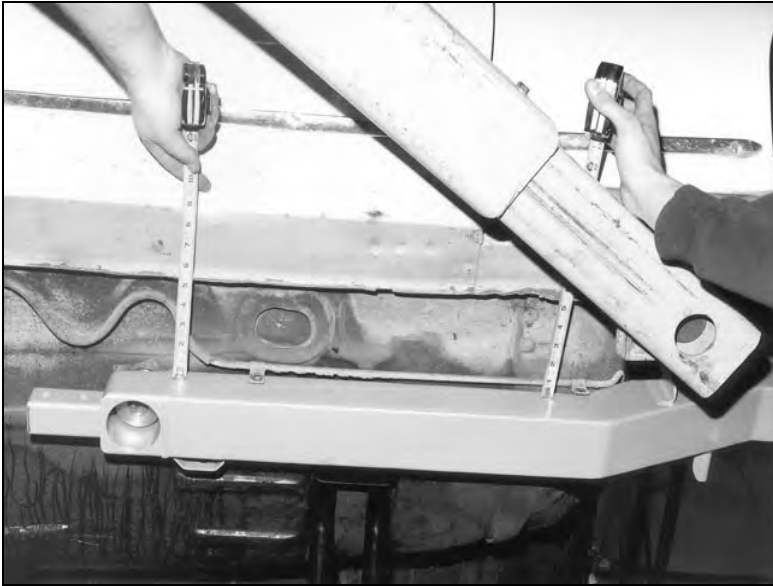

After you have finished the previous step, verify the distance from the rear frame gauge hole to the back of the frame. The length should be within 1/8 of an inch from side to side.

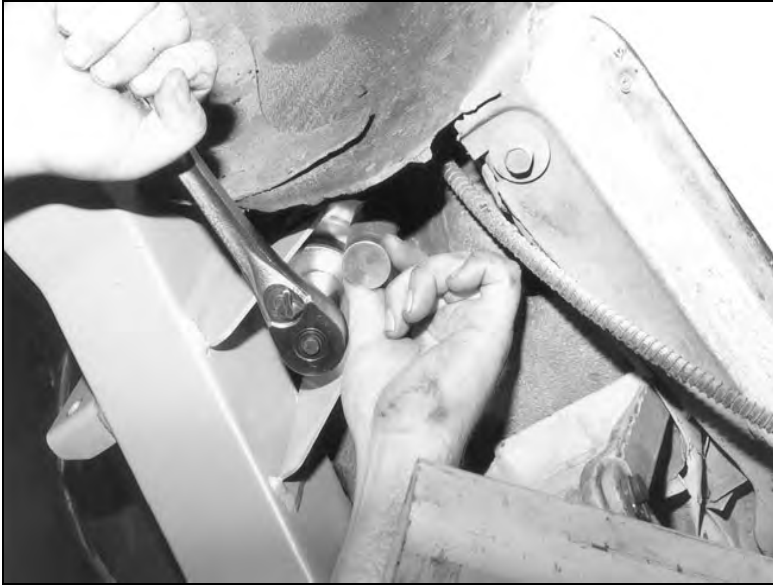

After all dimensions verify, tighten frame to the body mounts with the alignment pins installed. Verify your measurements after tightening.



In some cases, you may have to shim the subframe to get the front-end radiator core support to attach. You can put shims between the floor and the urethane to raise the frame in the front. Or, you can put shims between the frame and the urethane core support mounts. You can also shim the firewall body mounts to lower the frame at the core support. Some vehicles come from the factory with shims. If your vehicle has shims, it is probably best to reuse them.

If your core support will not line up after you have the clip aligned and attached to the body, then you need to reinstall the front sheet metal. Remember, these cars are over 30 years old so there is no telling what your car has been through. Sometimes you can get the core support to fit by simply loosening all its bolts and pushing it around and then retightening it. **Retorque all body mounts after 1000 miles of use.**

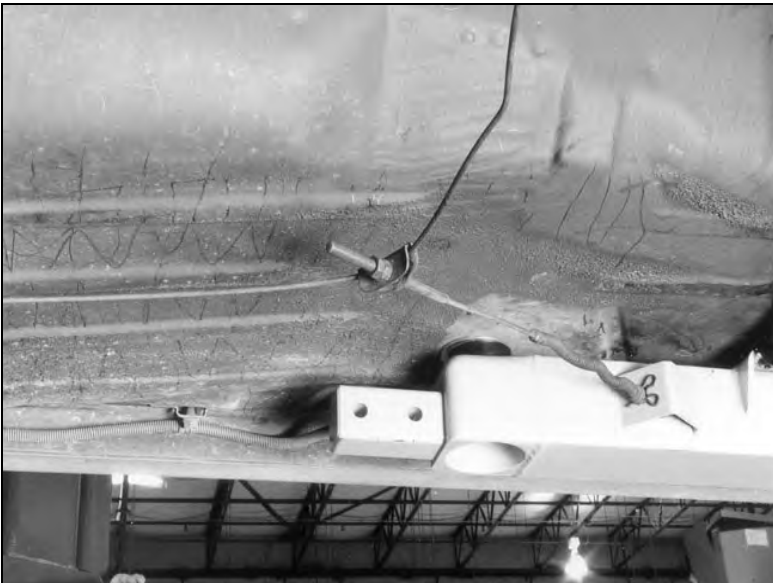

***Reinstalling Factory Components to Frame***

Reinstall the parking brake cable into the Chassisworks frame using the stock spring clip.



Attach the stock hook rod to the passenger side of the Chassisworks frame and stock parking brake cable.

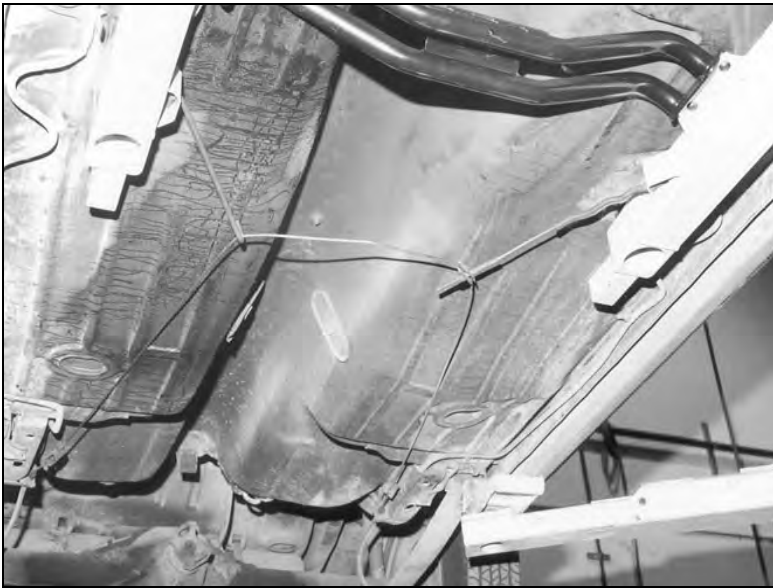

Adjust the parking brake mechanism for correct operation.



Drill two 1/4" holes in the driver side of the frame to attach the brake line clamps. Attach the clamp to the frame with the stock 5/16 self-tapping screw at the firewall and rear mounts.

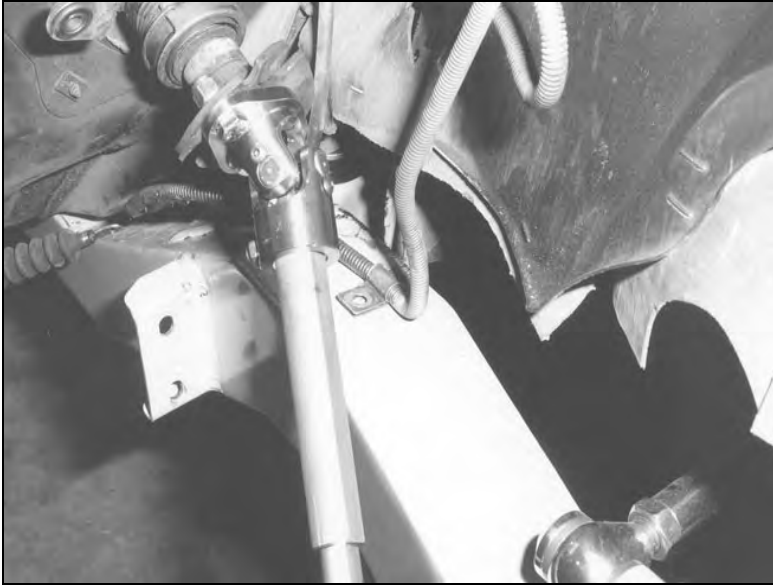

Bend the rear brake line under the master cylinder so its clamp sits on top of the frame where shown and attach it to the frame with its stock 5/16 self-tapping screw.

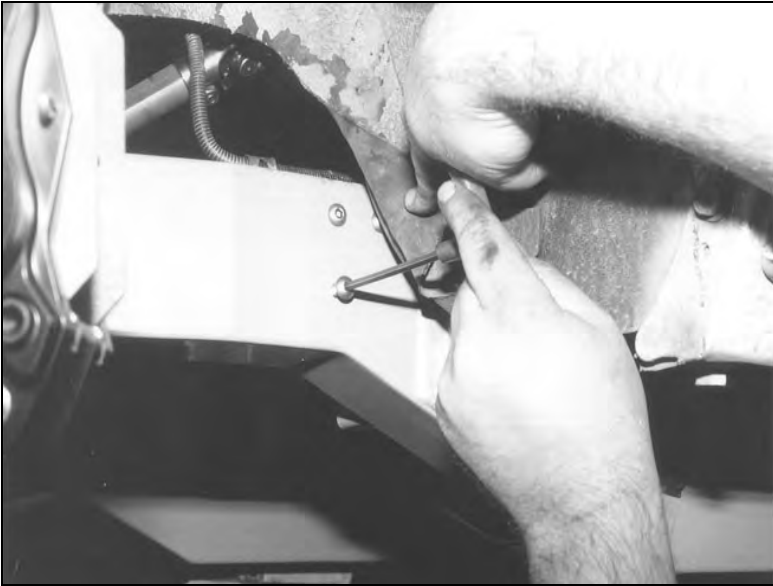

If you are using an automatic transmission, install three 5/16" button head screws to close the holes where the clutch linkage torsion shaft bracket goes.



Install a self-locking set screw in the spare hole in the top of the front frame horn. Do this for each side.



Install two 1/2" self-locking set screws in the spare holes for the bumper mount in the frame horn. Do this for each side.

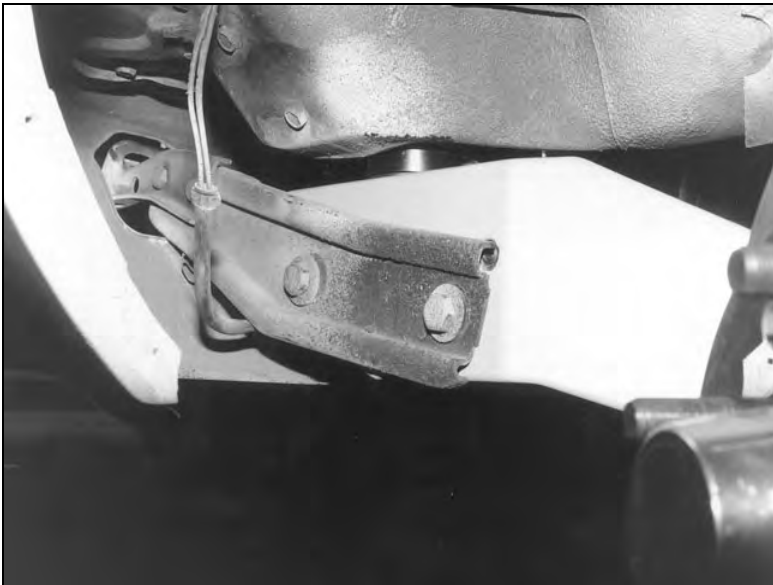

Reinstall the bumper brackets using the stock hardware in the correct holes. Reinstall the bumper and correctly align it with the body.



### ***Installing Steering Shaft***

This photo shows the flanged 1" DD u-joint that attaches to the stock steering column. There are also two u-joints shown that attach to the rack shaft. They are both sized as 3/4-36 x 3/4 DD. The longer u-joint is a VIBRATION isolator style u-joint. This type of u-joint will isolate some of the road vibration from the steering wheel. Both u-joints install the same way, however, we will show the isolator style u-joint in the installation photos.

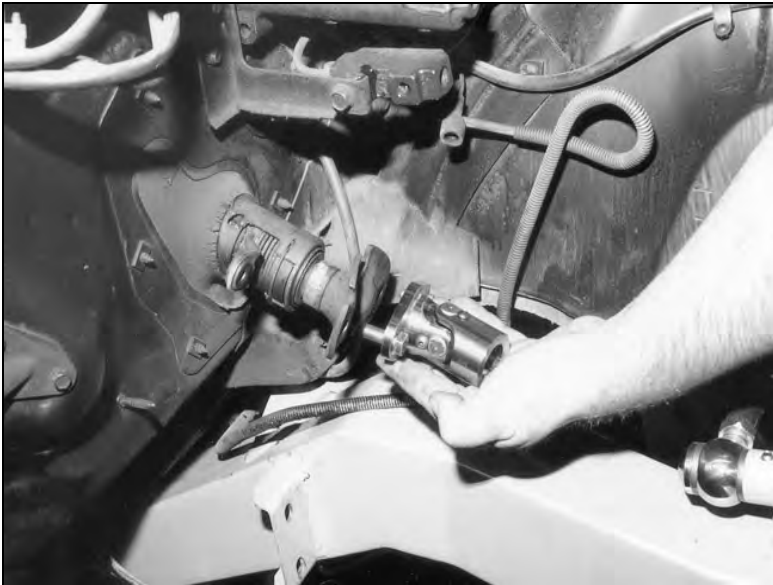

The first step to installing the steering shaft is to bolt the 1" DD shaft u-joint to the factory steering column where the rag joint attached. Just like the factory stock column, the flanged side of the u-joint has a 5/16" and a 3/8" bolt hole.



Install the 5/16" and the 3/8" bolts into the flange and place the u-joint up against the column. A flat washer goes over each bolt against the stock column flange and is secured with a locknut.



Slide the larger end of the steering shaft into the u-joint until it bottoms out. Then, just barely tighten one set screw so it won't fall out. Do not tighten the set screw enough to mark the tube. You will be removing it soon.



Slide the splined end of the u-joint onto the rack input shaft and tighten the set screws into the groove in the shaft.

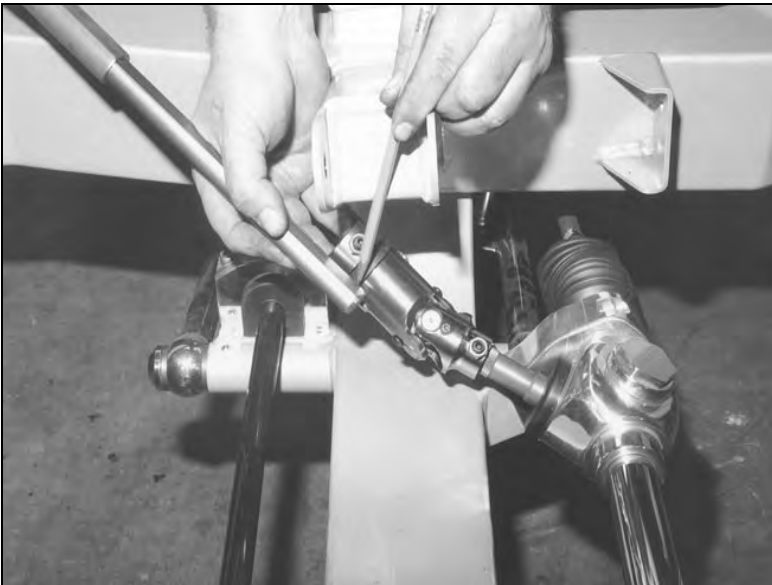

Hold the 3/4" DD lower end of the shaft up against the u-joint. Line them both up straight and parallel to each other. Mark the shaft even with the lower end of the rubber flange around the u-joint. The lower flange is even with the bottom of the bore in the u-joint. On the regular u-joint, make the 3/4" DD shaft even with the lower end of the 3/4" DD bore in the u-joint yoke. Use a hacksaw to cut the shaft to length and file a 1/32" chamfer on the end.



The intermediate shaft should be flush with the U-joint bore. If it protrudes more than the pointer shows, it will bind. Use a sander to shorten it for proper fit.



To install the 3/4" DD shaft, you will have to remove the rack clamps to push the rack forward. Use a 1/4" drill to make a dimple on the 3/4" DD shaft for the set screws.



Repeat the dimple procedure for the top u-joint. Do not drill the dimple so deep that the drill starts to make a 1/4" hole.



The final step after the shaft has been installed, is to verify that with the steering wheel level, the wheels point straight ahead. Rotate the rack so the wheels point straight ahead. Follow the procedure used when aligning the front end. Level the steering wheel. Slide the splined u-joint onto the rack shaft. Reinstall the rack clamps. Because the rack has 36 teeth, the steering wheel can only be positioned every 10 degrees. If you want perfect alignment, you can adjust the center position of the shaft by turning 1 tie rod in and the other out. Make sure you turn them equal amounts and in the direction that requires the least rotation. If you do this, be sure to verify the front-end alignment for toe-in.

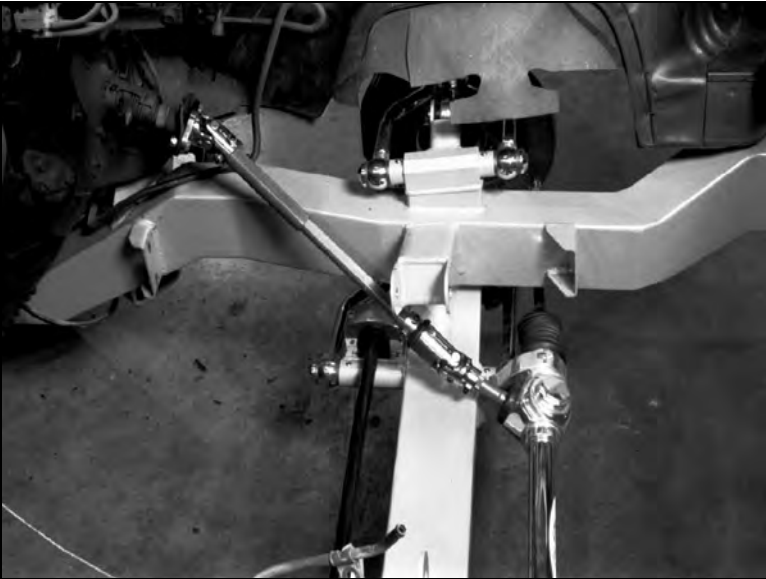

This is a photo of the completed installation. Wire the column lever to the position it would be in park or the key mechanism won't function properly. Paint the U-joints and steering column shaft to prevent rusting.

### ***Installing Fender Flaps***



The Chassisworks splash flaps replace the factory rubber flaps.



Use a flat blade screw driver and hammer to open up the staples.

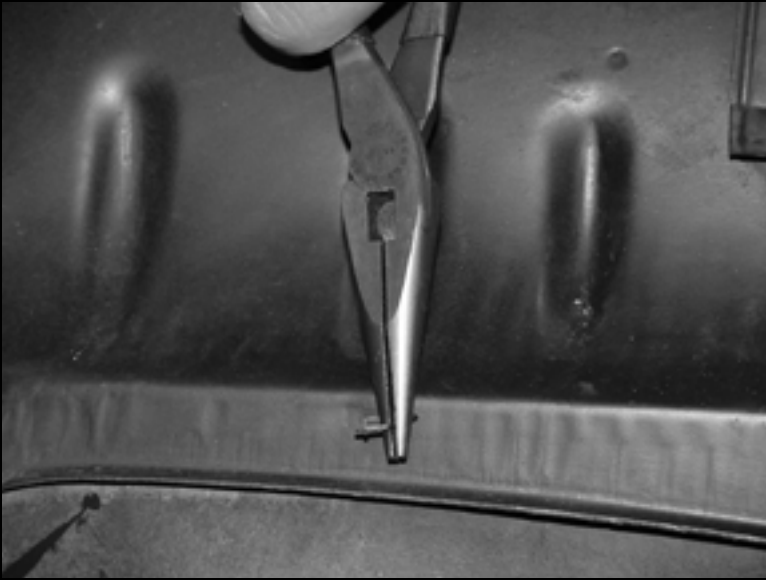

Use a pair of needle nose pliers to remove the staples.



Use a wire brush to remove any crud from the inside of the fender well.



Mark the center of the opening on the inner fender panel.



Drill a 1/8" hole centered in the opening on the flat of the inner fender panel.

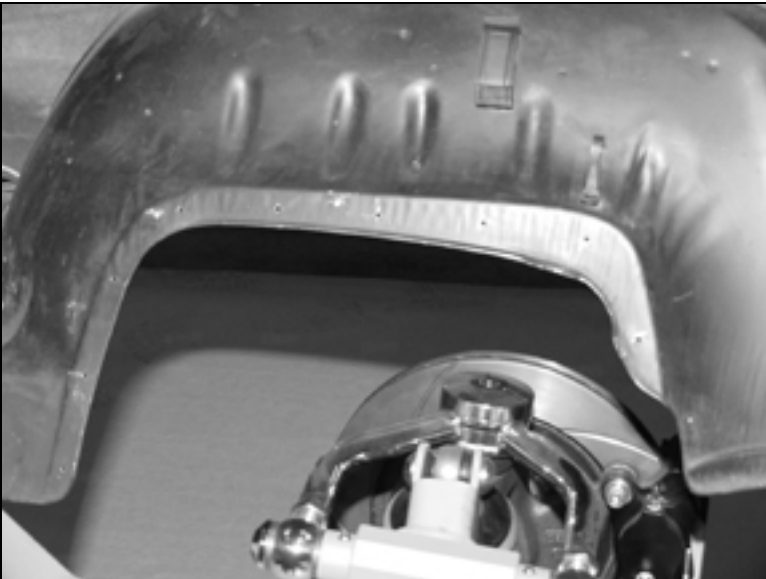

Drill a total of 10 holes in the fender panel on 2-1/2" centers.

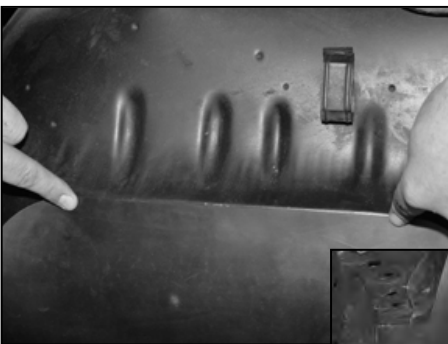

Lay the splash boot on top of the upper A-arm and even with the formed ledge in the fender panel.



Hold a 1x2 board across the top of the splash boot to hold the boot flush while drilling.



Use the top row of holes for a drill guide and drill the flap to match.



Move the splash flap to the tire side of the fender panel. Put a row of clecos in the top row of holes. The clecos are installed from the wheel side.



Drill the remaining rivet holes starting from the top. Use the end of your 1x2 held against the splash flap from the tire side for a backup tool to drill the rivet holes. Make sure the flap sits flush against the fender panel.



Install clecos in the remaining drilled holes. Remove the top center cleco and install the pop rivets from the engine side of the fender panel.



The pop rivet backup washers go against the rubber splash flap on the tire side of the fender panel.

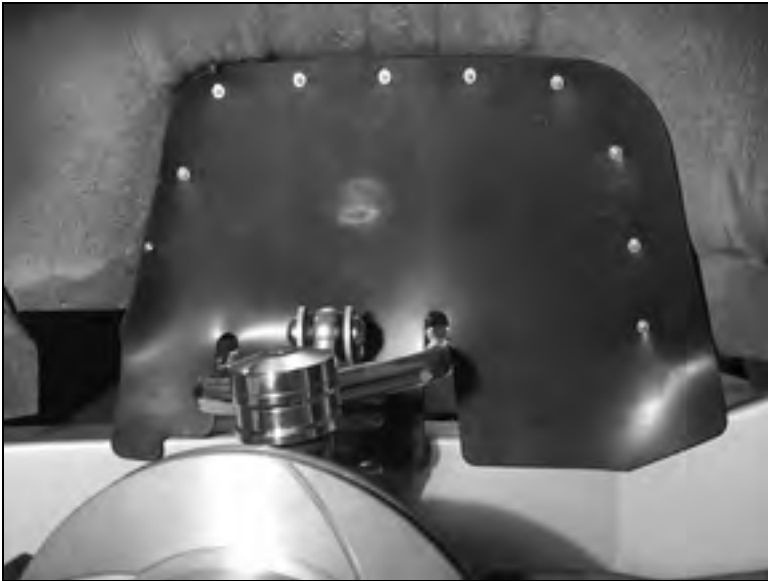

After all of the rivets with backing plates are installed, the splash boot will look like this viewed from the tire side of the splash panel.



This is a view of the splash boot completed installation for the passenger side viewed from the engine bay.



Repeat the procedure for the driver side.

Note: The Nova inner fender panel opening is shaped a little different than the Camaro. The Chassisworks splash flap is designed to fit both cars. The rivet positions will be slightly different, however, the procedures are the same.

## ***Installing Headers***

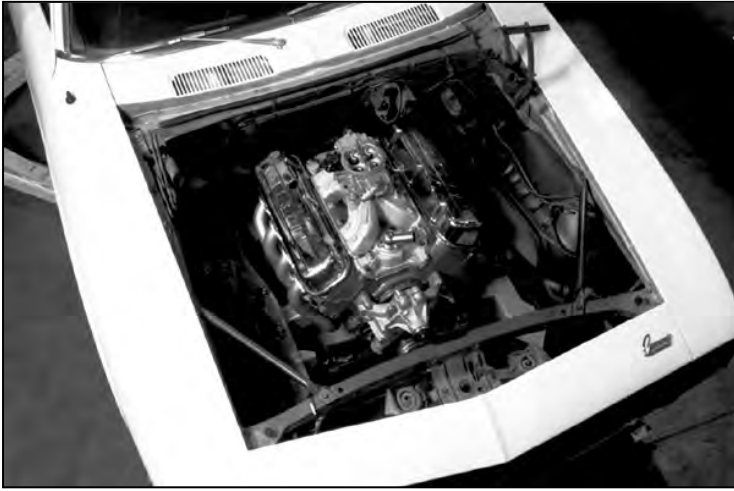

**Special Note:** We suggest leaving the headers in their plastic bag during the initial fit. If the headers do not fit your application, you can return them within 30 days of the purchase date for credit of the purchase price only. The returned parts must be in new condition (no scratches, dents or dings). Chassisworks reserves the right to return to the customer any header kit that is returned in substandard condition.

There are many manufactures of cylinder heads and several of them have made changes to the basic dimensions of the stock head. These changes will affect how our headers fit because we have built our headers to a close tolerance. Below are suggestions of modifications that can be made during your installation to insure the best fit.

1. Bolt hole resizing of the header flanges.
2. Different spark plugs to gain clearance for spark plug wires.
3. Different spark plug boots or wires to clear the header tubes.
4. Shimming the transmission mount up or down for additional tube clearance to the frame. If the transmission has been relocated from the stock location or replaced with a different model, the header fit may be affected.
5. Minor dimpling or denting of the header tubes.
6. Minor grinding of the header flange around the head bolts.
7. Changing the cylinder head fastener style for more clearance ( i.e. 12 point bolts or nuts, no washer or head studs).
8. The shape of the exhaust port may require a gasket change or modification for best seal.
9. Not all cylinder head manufactures use the same specifications on the width, height, and angle of the exhaust ports. If the ports are changed from the stock location in any way, the headers will be too wide to fit between the frame rails.
10. It is a good idea to test fit the headers on the engine prior to installing them. Make changes before you have the headers in the car.

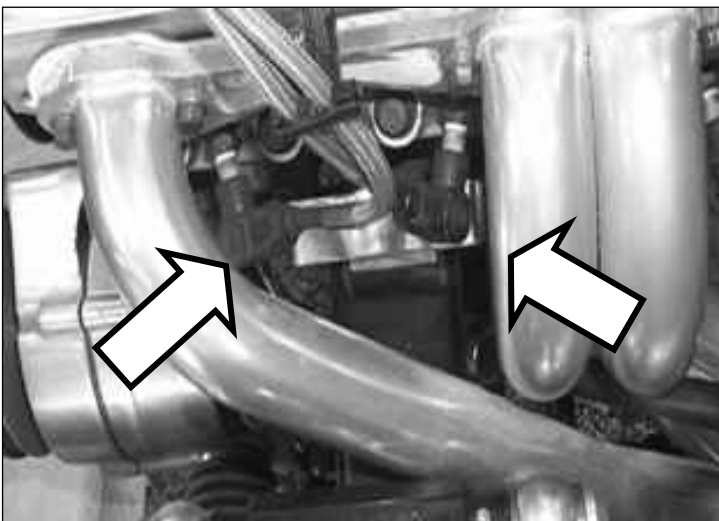

We suggest angle plug heads for better fit. The spark plug clearance will be very tight on the straight plug heads. A shorter length spark plug is available from most vendors. Champion C63YC is a good starting point for a street small block with straight plugs. However, even this spark plug will come very close to some tubes. MSD makes a heat shield material that should be wrapped around the tubes that have spark plug boot interference.

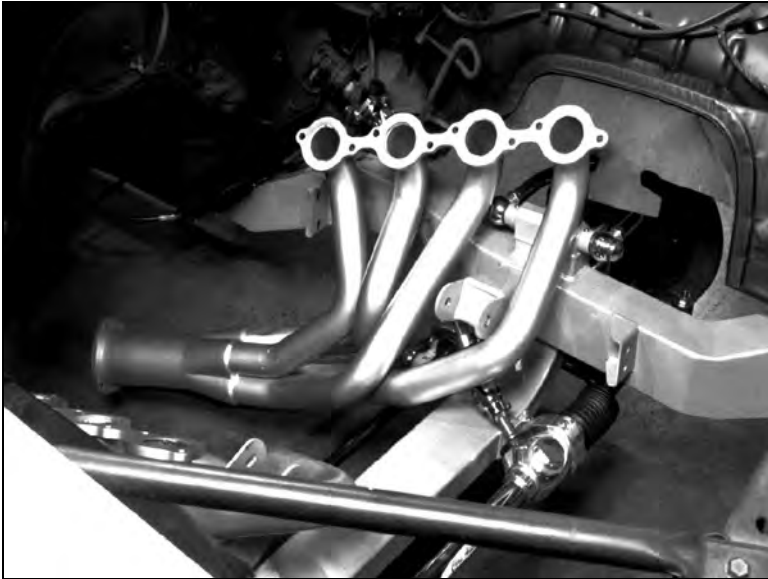

It is best to install the headers in the frame and lower the engine over them.



Engine installation is at least a three-person job. One on the hoist, and one on each side holding the headers.



After the headers and engine are installed, you will have to reinstall the steering column.

## ***Installing Subframe Connectors***

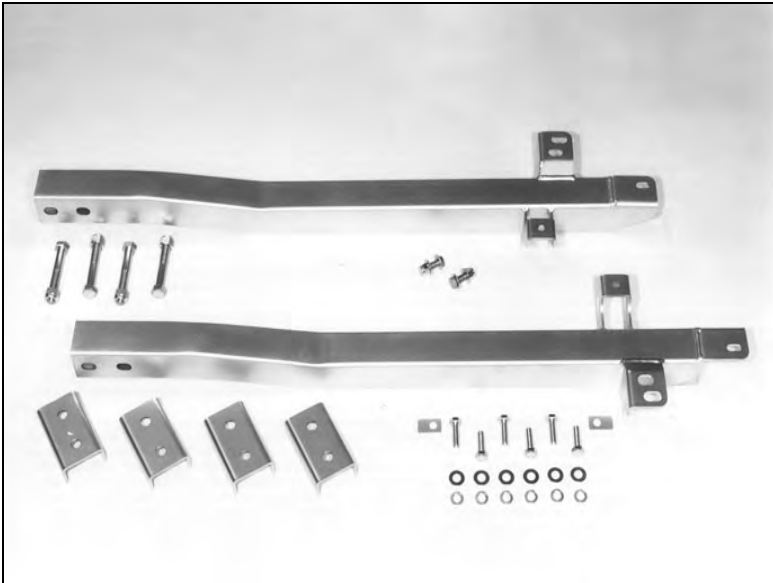

The subframe connector kit includes the items shown.

Part number 5601-20 is for the 1967-69 Camaro/Firebird.

Part number 5601-21 fits the 1968-72 Nova.



For this installation we have the car on our lift.

You can install them with the car on jack stands under the front and rear of the rocker panels. The car should be at least 14 inches off the ground.

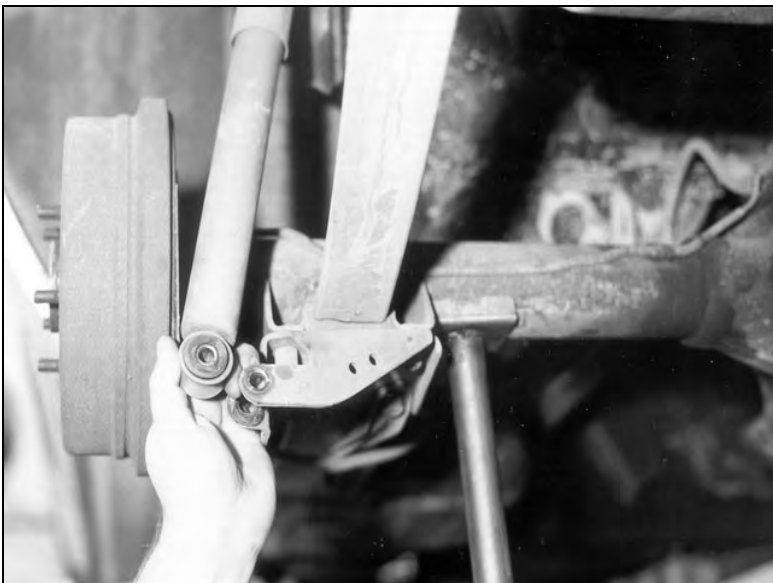

So there is no tension on the leaf springs, use a second pair of jack stands as support for the rear-axle housing. You can now remove the driver side shock absorber.



This is the driver side front leaf spring hanger. You will need to loosen it in order to get the rear on the subframe connector under the inside two bolts.

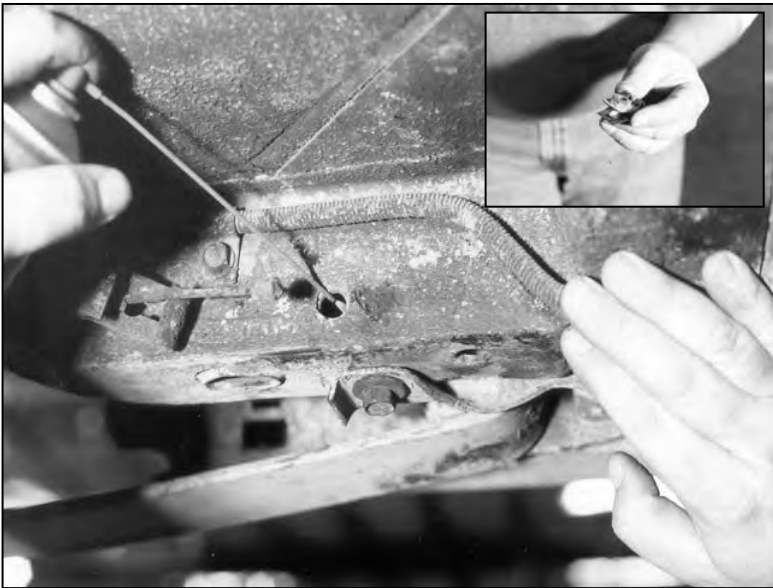

Unbolting the forward leaf spring hanger should never be done with an impact wrench. The nuts holding the bolts in place are just spot welded to these spring clips and they're easy to break.

Spray the nuts with a lubricant or penetrating oil before you start to loosen them.



Carefully remove the three bolts that hold the spring hanger in place. If the spring clips do break, they are available from both GM and the aftermarket.

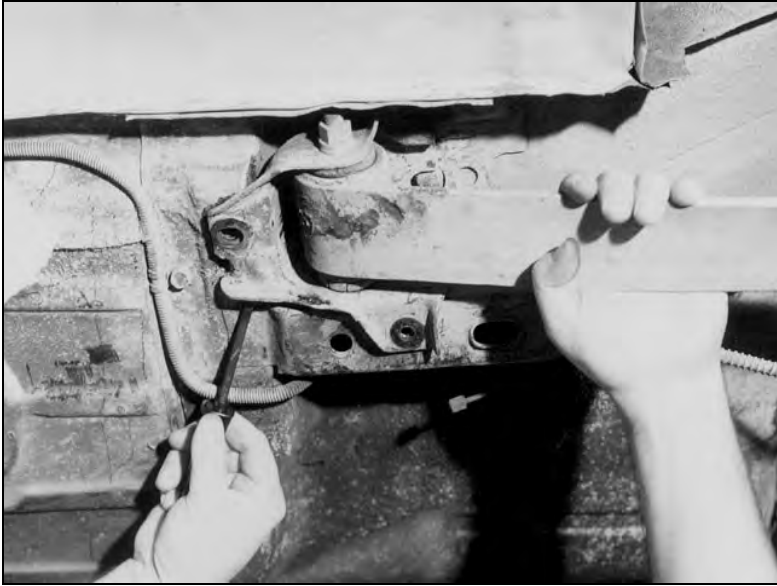

Once you have all the bolts removed, use a small pry bar to separate the spring hanger from the unibody frame rail and floor.



Slide the driver side subframe connector over the back of the bosses on the front-clip frame rail. Once you have it started over the boss, slide it as far forward as you can. The slotted holes allow for any slight length difference from car to car.





You will need two people for this step. Let the rear end housing down enough so the front spring hanger drops about 1/2 inch away from the body.

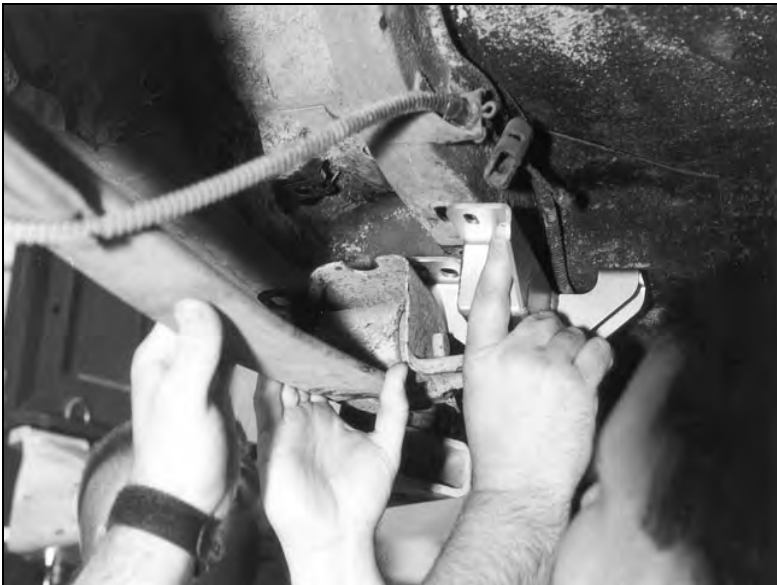

Have one person pull down on the front of the spring while the other person works the connector into place between the spring hanger and the car's body. The connector may need to be moved slightly front to rear to allow it to slide into place.



Since the mounting pad for the subframe connector doesn't extend to the outer spring-hanger bolt, a spacer is provided to keep the spring hanger in its correct location.

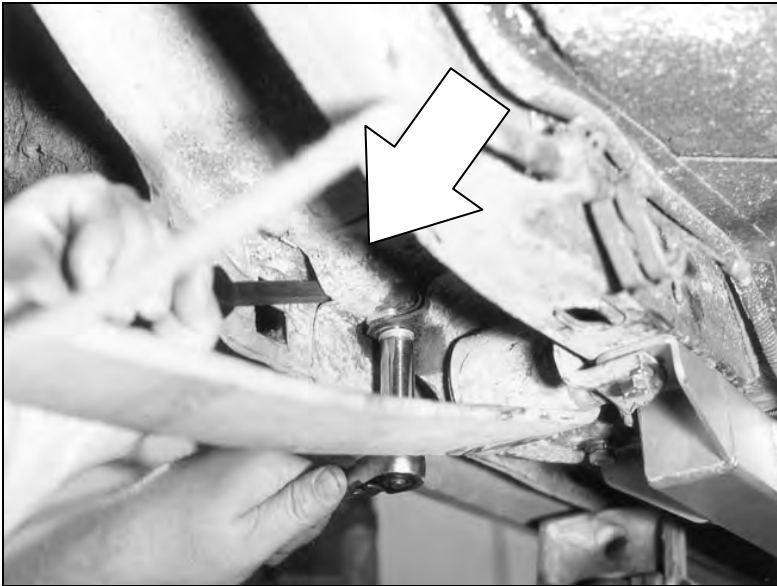

The spring clips can be just as tricky to reinstall as they were to get out. Use a bent-tip tool or your finger on the top of the bolt to hold it while starting the threads of the bolt.

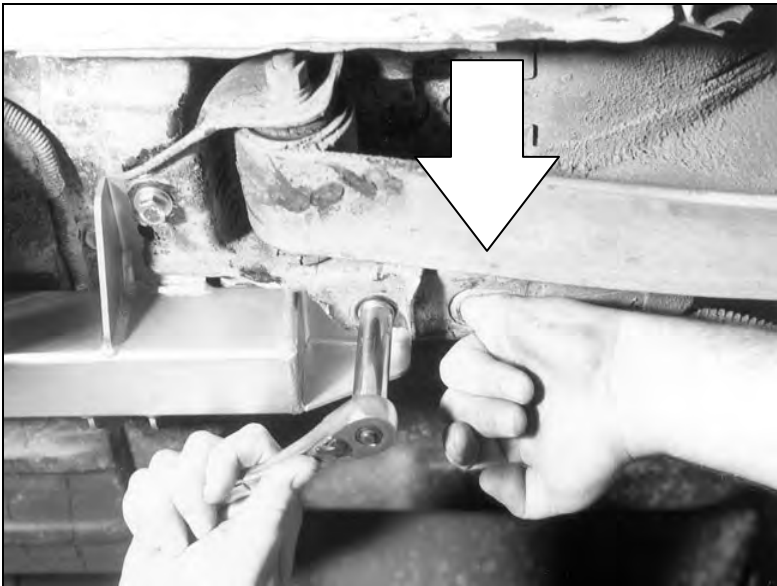

The subframe connector inner mounting bracket has been positioned so that the head of the bolt winds up under the rear seat. It's necessary to remove the seat and peel back the carpet to install the bolt.



Remove the door sill plates to get at the carpet. The carpet needs to be pulled back before drilling the hole through the floor from the bottom of the car.



Use a 3/8 inch diameter bit to drill a hole through the floor, using the hole in the subframe connector as a guide.



Insert the 3/8-24 x 1 hex bolt and 3/8 flat washer through the hole from inside the car under the rear seat. Hold the bolt with a 9/16 wrench while tightening from under the car.



Slide a 3/8 inch flat washer over the bolt and secure with a 3/8-24 locknut. Tighten all three bolts at the rear spring hanger before going to the next step.



Slide the two clamping brackets over the subframe connector. These are used to provide a firm attachment between the subframe boss and the subframe connector.



Install the 1/2-20 x 3 inch bolts and locknuts with the nut toward the outside of the car to keep them away from exhaust-system heat. Torque to 45 lb-ft.

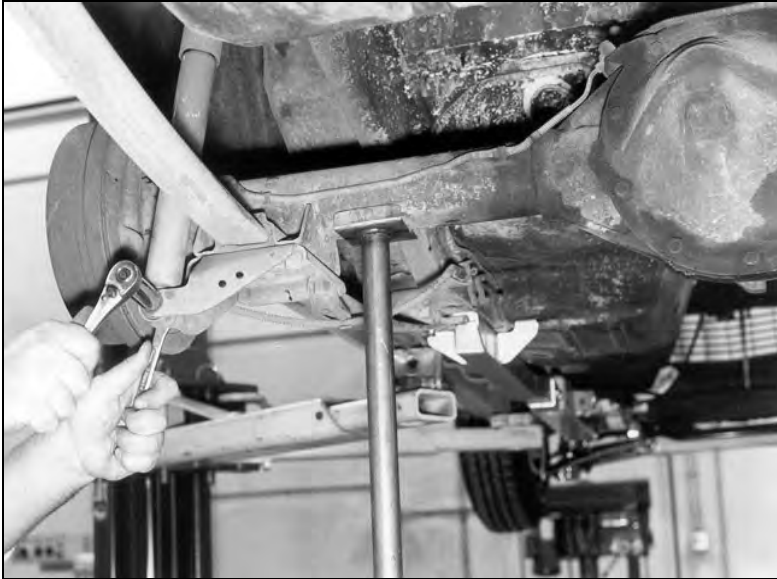

Reattach the shock absorber, then move on to the passenger side of the car to repeat the process.

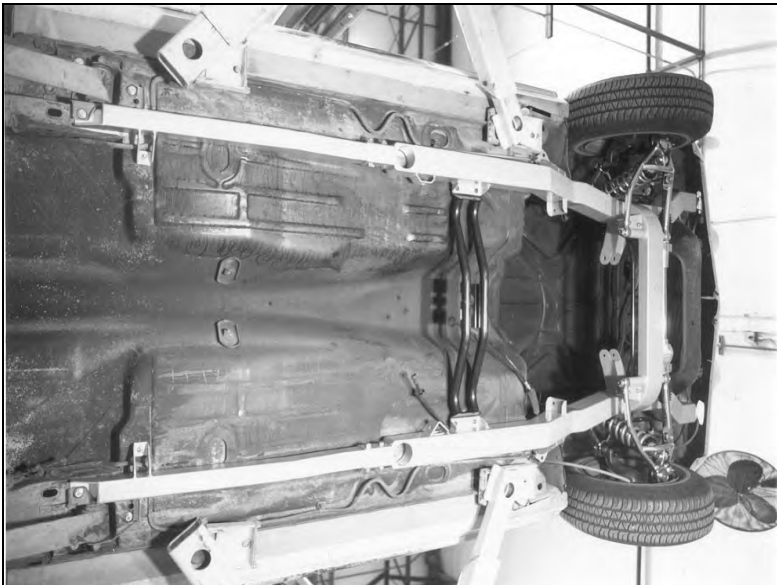

With the bolt-on frame clip and subframe connectors installed this is what your project should look like.

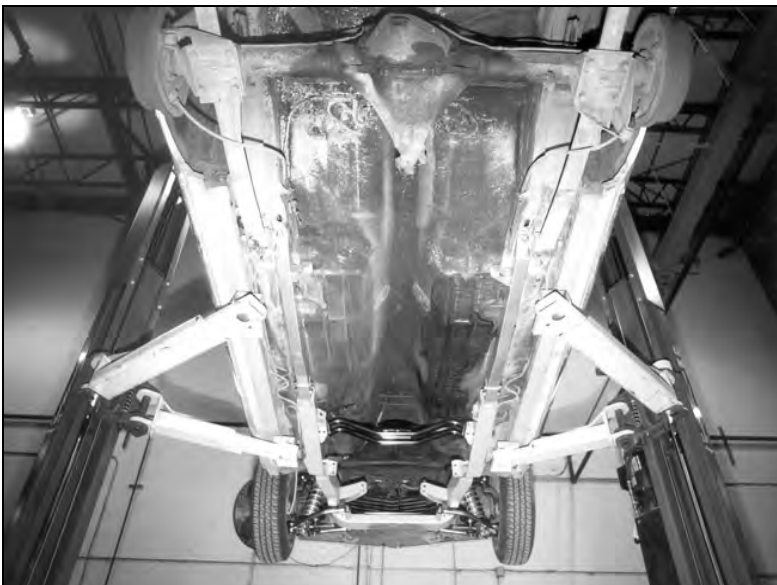

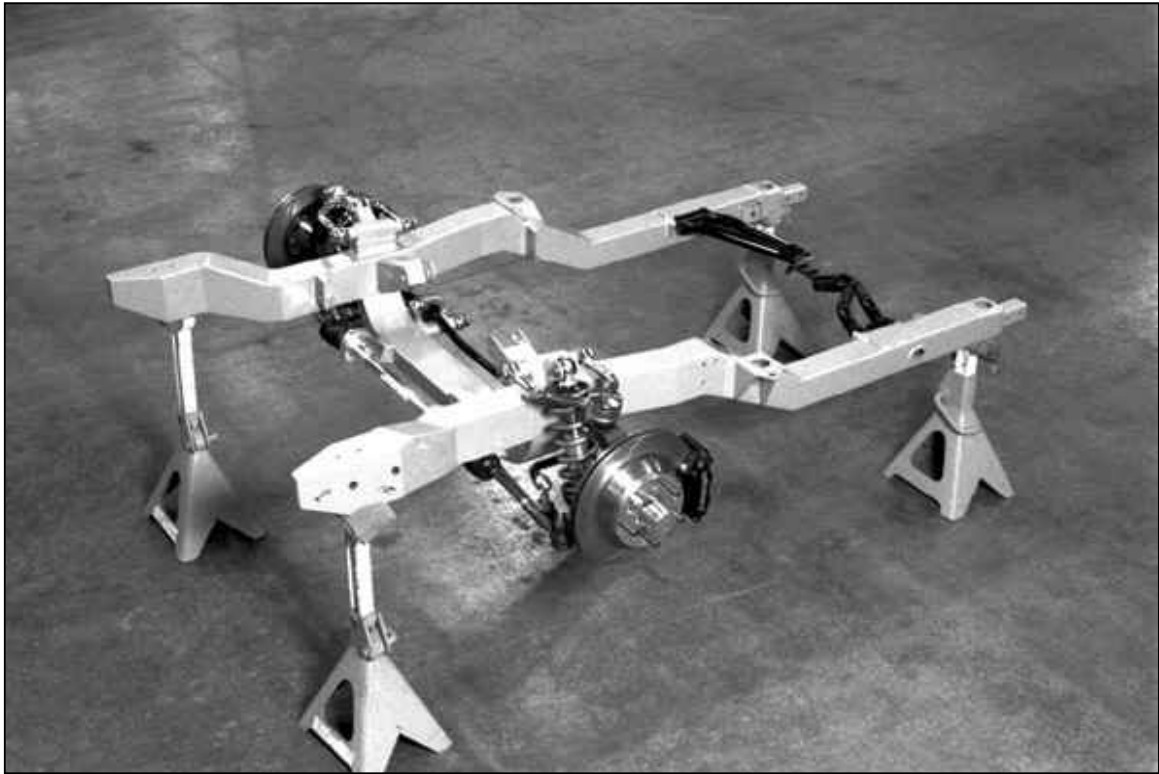

**WARRANTY NOTICE:**

There are NO WARRANTIES, either expressed or implied. Neither the seller nor manufacturer will be liable for any loss, damage or injury, direct or indirect, arising from the use or inability to determine the appropriate use of any products. Before any attempt at installation, all drawings and/or instruction sheets should be completely reviewed to determine the suitability of the product for its intended use. In this connection, the user assumes all responsibility and risk. We reserve the right to change specification without notice. Further, Chris Alston's Chassisworks, Inc., makes **NO GUARANTEE** in reference to any specific class legality of any component. **ALL PRODUCTS ARE INTENDED FOR RACING AND OFF-ROAD USE AND MAY NOT BE LEGALLY USED ON THE HIGHWAY.** The products offered for sale are true race-car components and, in all cases, require some fabrication skill. **NO PRODUCT OR SERVICE IS DESIGNED OR INTENDED TO PREVENT INJURY OR DEATH.**

Chris Alston's Chassisworks  
8661 Younger Creek Drive  
Sacramento, CA 95828  
Phone: 916-388-0288  
Technical Support: tech@cachassisworks.com

